

NAVSHIPS 0967-872-5020

TM-03816B-35/2

TM 11-5820-510-35-1

REPAIR AND MAINTENANCE  
TECHNICAL MANUAL

FOR

RADIO SET

AN/PRC-41A

DEPARTMENT OF THE NAVY  
NAVAL ELECTRONIC SYSTEMS COMMAND

*Published: 1 September 1969*

## LIST OF EFFECTIVE PAGES

PAGE NUMBERS	CHANGE IN EFFECT	PAGE NUMBERS	CHANGE IN EFFECT
Title Page	Original	4-1 to 4-60	Original
ii to xi	Original	5-1 to 5-116	Original
1-0 to 1-18	Original	6-1 to 6-54	Original

COLLINS RADIO COMPANY, CEDAR RAPIDS, IOWA,  
Contract: N00039- 69-C - 3511

Errors found in this publication (other than obvious typographical errors), which have not been corrected by means of Temporary Corrections or Permanent Changes should be reported. Such report should include the complete title of the publication and the publication number (short title); identify the page and line or figure and location of the error; and be forwarded to the Electronics Publications Section of the Bureau of Ships.

All Navy requests for NAVSHIPS electronics publications listed in the current issue of NAVSUP Publication 2002 "Requisitioning Guide and Index of Forms and Publications," Cognizance Symbol I, or in a subsequent issue of the Electronics Information Bulletin should be directed to the appropriate Forms and Publications Supply Point.

TM 11-5820-510-35-1  
NAVELEX 0967-LP-872-5021  
C 1

CHANGE }  
NO.1

HEADQUARTERS  
DEPARTMENT OF THE ARMY  
WASHINGTON, DC, 18, August 1980

**Repair and Maintenance Technical Manual  
RADIO SET  
AN/PRC-41A (NSN 5820-00-889-3997)**

TM 11-5820-510-35-1 and NAVSHIPS 0967-872-5020, 1 September 1969, is changed as follows:

1. The title of the manual is changed as shown above.
2. A vertical bar appears opposite changed material.
3. Remove and insert pages as indicated in the page list below:

<i>Remove</i>	<i>Insert</i>
4-1 and 4-2 .....	4-1 and 4-2
5-1 and 5-2 .....	5-1 and 5-2
5-11 and 5-12 .....	5-11 and 5-12
5-15 and 5-16 .....	5-15 and 5-16
5-25 and 5-26 .....	5-25 and 5-26
None.....	5-86.1

4. File this change sheet in the front of the manual for reference purposes.

By Order of the Secretaries of the Army, the Navy, and the Air Force:

Official:

E. C. MEYER  
*General, United States Army  
Chief of Staff*

J. C. PENNINGTON  
*Major General, United States Army  
The Adjutant General*

EARL B. FOWLER  
*Rear Admiral, United States Navy  
Commander, Naval Electronic  
Systems Command*

DISTRIBUTION:

To be distributed in accordance with DA Form 12-51, Direct and General Support Maintenance requirements for AN/PRC-41.

NAVSHIPS 0967-872-5020  
 TM-03816B-35/2  
 TM11-5820-510-35-1

**TABLE OF CONTENTS**

Paragraph	Page	Paragraph	Page
SECTION 1 - GENERAL INFORMATION		SECTION 1 - GENERAL INFORMATION (Cont)	
1-1. Scope.....	1-1	d. Receiver Data.....	1-15
1-2. Equipment Supplied.....	1-1	e. Main Receiver Auxiliary Output Data .....	1-18
1-3. Equipment Required But Not Supplied .....	1-1	f. Guard Receiver Data.....	1-18
1-4. General Description .....	1-4	g. Guard Receiver Auxiliary Output Data .....	1-18
1-5. Description of Units .....	1-4	1-7. Factory or Field Changes .....	1-18
a. General.....	1-4	1-8. Preparation for Reshipment.....	1-19
b. Radio Set AN/PRC-41A .....	1-4		
(1) Radio Set Case CY-3883/ PRC-41 .....	1-4	SECTION 4 - TROUBLESHOOTING	
(2) Radio Receiver-Transmitter RT-695A/PRC-41 .....	1-5	4-1. Logical Troubleshooting .....	4-1
(3) Receiver-Transmitter Case .....	1-7	a. Historical Data Availability .....	4-1
(4) Storage Battery BB-451/U.....	1-7	(1) Symptom Recognition.....	4-1
(a) General .....	1-7	(2) Symptom Elaboration.....	4-1
(b) Construction.....	1-8	(3) Listing Probable Faulty Function.....	4-1
(c) Cells.....	1-8	(4) Localizing the Faulty Function.....	4-1
(d) Charge Retention (Dry).....	1-8	(5) Localizing Trouble to the Circuit .....	4-1
(e) Activation .....	1-8	(6) Failure Analysis .....	4-1
(f) Charge Acceptance .....	1-8	b. General Trouble Isolation .....	4-1
(g) Storage .....	1-8	(1) Use of Signal Generator Pad CN-315/URM-26 .....	4-1
(5) Antenna AS-1404/PRC-41.....	1-8	(2) Transistor Servicing.....	4-1
(6) Handset H-33R/PT .....	1-9	4-2. Overall Functional Description.....	4-5
(7) Rucksack Frame.....	1-9	a. Radio Set AN/PRC-41A.....	4-5
(8) Special Purpose Electrical Cable Assembly CX-10831/ PRC-41A.....	1-9	b. Test Points.....	4-7
c. Radio Set Accessory Kit.....	1-9	c. Overall Trouble Isolation.....	4-9
MK-706/PRC-41.....	1-9	(1) Test Setup .....	4-9
(1) Electronic Equipment Case CY-3885/PRC-41 .....	1-9	(2) Test Equipment Required.....	4-9
(2) Power Supply PP-3700/... PRC-41 .....	1-10	(a) Signal Generator AN/ USM-44A .....	4-9
(3) Mountings MT-2976/PRC-41 and MT-2977/PRC-41.....	1-10	(b) RF Wattmeter AN/ URM-43C .....	4-9
(4) Antenna AS-1405/PRC-41 and Accessories.....	1-11	(c) Electronic Multimeter TS-505/U.....	4-9
(5) Antenna Mounting Brackets .....	1-11	(d) Signal Generator Pad CN-315/urm-26 .....	4-9
(6) Radio Frequency Cable Assembly CG-55G/U .....	1-11	(e) Fuse MX-1730/U .....	4-9
(7) Power Electric Cable Assembly CX-8686/PRC-41 .....	1-11	4-3. Overall Main Receiver Functional Section .....	4-11
(8) Power Electric Cable Assembly CX-8687/PRC-41 .....	1-11	a. Description .....	4-11
(9) Special Purpose Electrical Cable Assembly CX-8688/ PRC-41 .....	1-12	b. Test Data .....	4-11
(10) DC Adapter Cable.....	1-12	(1) Test Equipment Required.....	4-11
(11) Maintenance Cable Kit .....	1-12	(a) Signal Generator AN/ USM-44A .....	4-11
(12) Tool Kit.....	1-15	(b) Signal Generator Pad CN-315/URM-26 .....	4-11
1-6. Reference Data.....	1-15	(c) Fuse MX-1730/U .....	4-11
a. Power Requirements .....	1-15	(d) Output Power Meter ME-2/U .....	4-11
b. Frequency Data .....	1-15	(2) Test Setup .....	4-11
c. Transmitter Data.....	1-15	(3) Functional Section Performance Test .....	4-11

NAVSHIPS 0967-872-5020

TM-03816B-35/2

TM11-5820-510-35-1

**TABLE OF CONTENTS (Cont)**

Paragraph	Page	Paragraph	Page
<b>SECTION 4 - TROUBLESHOOTING (Cont)</b>		<b>Section.4 - TROUBLESHOOTING (Cont)</b>	
c. Main Receiver Circuit Description.....	4-11	4-4. Overall Guard Receiver Functional	
(1) Functional Description.....	4-11	Section .....	4-20
(a) RF and Power Amplifier		a. Description .....	4-20
Module 1A8.....	4-12	b. Test Data.....	4-20
1. RF Amplifiers V1		(1) Test Equipment Required .....	4-20
Through V4 .....	4-12	(a) Signal Generator AN/	
2. Power Amplifier V5.....	4-12	USM-44A.....	4-20
3. AVC Amplifier Q1 .....	4-12	(b) Signal Generator Pad	
4. Output Control		CN-315/Urm-26 .....	4-20
Relay K1 .....	4-12	(c) Fuse MX-1730/U .....	4-20
(b) 1t and 2nd IF Amplifier		(d) Output Power Meter	
Module 1A2.....	4-12	ME-2/U .....	4-20
1. IF Amplifiers Q1 and		(2) Test Setup .....	4-20
Q2.....	4-12	(3) Functional Section Performance	
2. Second Receiver		Test.....	4-21
Mixer Q3.....	4-12	c. Guard Receiver Circuit	
3. Third Receiver Mixer		Description .....	4-21
and Transmitter		(1) Functional Description .....	4-21
Buffer Q6.....	4-12	(a) Guard Receiver Module	
4. Relay Switching .....	4-15	1A7.....	4-21
(c) 3rd IF and Squelch Module		1. RF Amplifiers Q1 and	
1A3.....	4-15	Q2 .....	4-21
1. Filter 1A3FL1 and		2. Oscillator Q4 .....	4-21
IF Amplifiers Q1		3. IF Amplifiers Q5, Q6,	
Q2, and Q3.....	4-15	Q7, Q8 and Q9.....	4-21
2. Audio Detector Q4.....	4-15	4. Detector Q10.....	4-21
3. AVC Detector Q6.....	4-15	5. Audio Amplifier Q15	
4. AVC Amplifiers Q5		and Squelch Ampli-	
and Q7.....	4-15	fier Q13 .....	4-21
5. DC Amplifier Q10 and		6. AVC Amplifiers Q11	
Squelch Relay		and Q12.....	4-22
Amplifier Q8.....	4-15	(2) Test Data .....	4-22
(d) Audio Module 1A4.....	4-16	(a) Test Equipment Required .....	4-22
(2) Test Data.....	4-16	1. Oscilloscope AN/	
(a) Test Equipment Required.....	4-16	USM- 105A .....	4-22
1. Oscilloscope AN/		2. Signal Generator AN/	
USM-105A .....	4-16	USM-44A .....	4-22
2. Audio Oscillator TS		3. Signal Generator Pad	
382B/U.....	4-16	CN-315/URM-26 .....	4-22
3. Signal Generator AN/		4. Fuse MX- 1730/U .....	4-22
USM-44A .....	4-16	5. Electronic Multimeter	
4. Signal Generator AN/		TS-505/U.....	4-22
URM-25D.....	4-16	(b) Test Setup .....	4-22
5. Electronic Multi		(c) Guard Receiver Functional	
meter TS-505/U .....	4-16	Section Circuit Trouble	
6. Output Power Meter		Isolation .....	4-22
ME -2/U .....	4-16	4-5. Overall Transmitter Functional	
7. Signal Generator Pad		Section .....	4-23
CN-315/URM-26.....	4-16	a. Description .....	4-23
8. MX-1730/U.....	4-16	b. Test Data.....	4-24
(b). Test Setup.....	4-16	(1) Test Equipment Required .....	4-24
(c) Main Receiver Functional		(2) Test Setup .....	4-24
Section Circuit Trouble		(3) Functional Section Performance	
Isolation.....	4-16	Test.....	4-24

NAVSHIPS 0967-872-5020  
 TM-03816B-35/2  
 TM11-5820-510-35-1

**TABLE OF CONTENTS (Cont)**

Paragraph	Page	Paragraph	Page
<b>SECTION 4 - TROUBLESHOOTING (Cont)</b>		<b>SECTION 4 - TROUBLESHOOTING (Cont)</b>	
c.	Transmitter Circuit Description		4-24
(1)	Functional Description		4-24
(a)	1st and 2nd IF Amplifier Module 1A2		4-24
1.	Third Receiver Mixer and Transmitter Buffer Q6 4-24		
2.	Transmitter Mixer Q4		4-24
3.	IF Amplifiers Q1 and Q2 and Second Trans- mitter Mixer 1A9CR1		4-27
(b)	RF and Power Amplifier Module 1A8		4-27
(c)	Modulator Module 1A6		4-27
(2)	Test Data		4-27
(a)	Test Equipment Required		4-27
1.	RF Wattmeter AN/ URM-43C		4-27
2.	Electronic Multi meter TS-505/U		4-27
3.	Audio Oscillator TS 382B/U		4-27
(b)	Test Setup		4-27
(c)	Transmitter Functional Section Circuit Trouble Isolation		4-27
4-6.	Overall Subordinate Circuits		4-27
a.	Description		4-27
b.	AF Amplifier Assembly (Buffer)		4-30
(1)	Functional Description of AF Amplifier Assembly (Buffer)		4-30
(2)	Test Data		4-30
(a)	Test Equipment Required		4-30
1.	Signal Generator AN/ USM-44A		4-30
2.	Signal Generator Pad CN-315/URM-26		4-30
3.	Fuse MX-1730/U		4-30
4.	Electronic Multi- meter TS-505/U		4-30
(b)	Test Setup		4-30
(c)	AF Amplifier Assembly (Buffer) Functional Section Circuit, Trouble Isolation		4-30
c.	Main Chassis 1A9		4-31
(1)	Functional Description		4-31
(a)	Receive-Transmit Switch		4-31
(2)	Test Data		4-31
d.	Primary Power Circuits		4-31
(1)	Functional Description		4-31
(a)	Storage Battery BB-451/U		4-31
(b)	Power Supply PP-3700/ PRC-41		4-32
(2)	Storage Battery BB-451/U, Test Data		4-32
(3)	Power Supply PP-3700/ PRC-41, Test Data		4-33
(a)	Test Equipment Required		4-33
(b)	Test Setup		4-33
(c)	Power Supply PP-3700/ PRC-41, Circuit Trouble Isolation		4-33
e.	Power Distribution Circuits		4-33
(1)	Functional Description		4-33
(a)	DC Power Supply Module 1A1		4-36
(b)	Filament Circuits		4-36
(c)	Receive-transmit Relays, Dial Light, and Guard Receive Module		4-39
(2)	Test Data		4-39
(a)	Test Equipment Required		4-39
(b)	Test Setup		4-39
(c)	Power Distribution Circuit, Trouble Isolation		4-42
f.	Frequency Generator Circuits		4-42
(1)	Functional Description, Re- ceive Operation		4-42
(2)	Functional Description, Transmit Operation		4-42
(3)	IF Frequency Calculation		4-42
(a)	Spectrum Generator Module		4-42
(b)	High-Frequency Oscilla- tor 1A2Q5		4-43
(c)	Low-Frequency Oscilla- tor 1A2Q7		4-43
(4)	Test Data		4-44
(a)	Test Equipment Required		4-44
(b)	Test Setup		4-44
(c)	Frequency Generation Circuit, Trouble Isolation		4-44
g.	Control Circuits		4-44
(1)	Functional Description		4-44
(a)	Mechanical Frequency Selection		4-44
(b)	Receive Operational Switching		4-44
(c)	Transmit Operational Switching		4-46
(2)	Control Circuits Trouble Isolation		4-47

**TABLE OF CONTENTS (Cont)**

Paragraph	Page	Paragraph	Page
SECTION 4 - TROUBLESHOOTING (Cont)		SECTION 5 - MAINTENANCE (Cont)	
h.		g.	
Omnidirectional and Directional		Final Adjustments .....	5-34
Antennas .....	4-47	(1) General .....	
(1) Antenna AS-1405/PRC-41 .....	4-47	(a) 3rd IF and Squelch Module .....	5-34
(2) Antenna AS-1404/PRC-41 .....	4-47	5-4. Repair .....	5-35
4-7. History of Modifications .....	4-47	a. Removal, Repair, and Replacement	
SECTION 5 - MAINTENANCE		of Parts, Modules, and Units .....	5-35
5-1. Failure, and Performance and Opera-		b. Module Removal .....	5-35
tional Reports .....	5-1	c. Disassembly .....	5-35
5-2. Preventive Maintenance .....	5-1	(1) 1st and 2nd IF Amplifier	
a. Maintenance Standards .....	5-1	Module .....	5-35
(1) General .....	5-1	(a) Z1, Z2, and Z3 Slug Rack .....	5-35
(2) Test Equipment and Special		(b) Z4, Z5, and Z6 Slug Rack .....	5-37
Tools .....	5-1	(c) Oscillator and Switchboard	
(3) Special Procedures .....	5-1	and RF Coil Assemblies .....	5-37
(a) Junction Box .....	5-1	(2) RF and Power Amplifier	
(4) Reference Standard		Module .....	5-37
Procedures .....	5-1	(a) Z1, Z2, and Z3 Tuned	
(5) Preventive Maintenance		Circuits .....	5-37
Procedures .....	5-1	(b) Z4 and Z5 Tuned Circuits .....	5-37
(6) Periodic Schedule Charts		(3) Spectrum Generator Module .....	5-37
5-3. Tuning and Adjustment .....	5-27	(a) Crystal and Switch Section	
a. General .....	5-27	S2 .....	5-37
(1) Test Equipment .....	5-27	(b) Coil Turret Section .....	5-38
(2) Special Tools and Cables .....	5-27	(c) Tuning Circuit Section .....	5-38
(3) Preliminary Test Setup .....	5-27	(4) Radio Receiver-Transmitter	
b. Alignment of High- and Low -		RT-695A/PRC-41 Main	
Frequency Oscillators of 1st		Chassis .....	5-38
and 2nd IF Amplifier Module .....	5-28	d. Repair .....	5-38
(1) Test Equipment Required .....	5-28	e. Reassembly .....	5-38
(2) Alignment Setup .....	5-28	(1) 1st and 2nd IF Amplifier	
(3) Procedure .....	5-28	Module .....	5-38
c. Alignment of 1st and 2nd IF Amp-		(a) Z1, Z2, and Z3 Slug Rack .....	5-38
lifier Stages of 1st and 2nd IF		(b) Z4, Z5, and Z6 Slug Rack .....	5-39
Amplifier Module .....	5-28	(c) Oscillator and Switchboard,	
(1) Test Equipment Required .....	5-28	and RF Coil	
(2) Alignment Setup .....	5-28	Assemblies .....	5-39
(3) Procedure .....	5-29	(2) RF and Power Amplifier	
d. Alignment of Spectrum Generator		Module .....	5-39
Module .....	5-30	(a) Z1, Z2, and Z3 Tuned	
(1) Test Equipment Required .....	5-30	Circuits .....	5-39
(2) Alignment Setup .....	5-30	(b) Z4 and Z5 Tuned Circuits .....	5-39
(3) Procedure .....	5-30	(3) Spectrum Generator Module .....	5-40
e. Alignment of RF and Power		(a) Crystal and Switch S2	
Amplifier Module .....	5-31	Section .....	5-40
(1) Test Equipment Required .....	5-31	(b) Coil Turret Section .....	5-40
(2) Alignment Setup .....	5-31	(c) Tuning Circuit Section .....	5-40
(3) Procedure .....	5-32	(4) Radio Receiver-Transmitter	
f. Alignment of Guard Receiver		RT-695A/PRC-41 Main	
Module 5-33		Chassis .....	5-40
(1) Test Equipment Required .....	5-33	f. Synchronization .....	5-41
(2) Alignment Setup .....	5-33	(1) 1st and 2nd IF Amplifier	
(3) Procedure .....	5-34	Module .....	5-41

ORIGINAL

**TABLE OF CONTENTS (Cont)**

Paragraph	Page	Paragraph	Page
	<b>SECTION 5 - MAINTENANCE (Cont)</b>		<b>SECTION 5 - MAINTENANCE (Cont)</b>
(2)	RF and Power Amplifier Module .....5-41	5-6.	Lubrication .....5-42
(3)	Spectrum Generator Module .....5-41	5-7.	Parts Location.....5-42
g.	Replacement 5-41		<b>SECTION 6 - PARTS LIST</b>
(1)	Spectrum Generator Module .....5-41	6-1.	Introduction.....6-1
(3)	RF and Power Amplifier Module.....5-42	a.	Reference Designations.....6-1
(3)	1st and 2nd IF Amplifier Module.....5-42	b.	Ref Desig Prefix .....6-1
5-5.	Voltage and Resistance Measurements.....5-42	6-2.	List of Units .....6-1
		6-3.	Maintenance Parts List.....6-1.1
		6-4.	List of Manufacturers.....6-1.1
		6-5.	Stock Number Identification.....6-1.1
		6-6.	Notes.....6-1.1

**LIST OF ILLUSTRATIONS**

Figure	Page	Figure	Page
	<b>SECTION 1 - GENERAL INFORMATION</b>		<b>SECTION 4 - TROUBLESHOOTING</b>
1-1.	Radio Set AN/PRC-41A, Operating Configuration .....1-0	4-1.	Radio Receiver- Transmitter, RT-695A/ PRC-41, Module and Test-Point Locations.....4-2
1-2.	Radio Set AN/PRC-41A, Equipment Contents of Radio Set Case CY-3883/PRC-41 .....1-5	4-2.	Transistor Base Diagrams .....4-5
1-3.	Radio Set Accessory Kit MK-706/ PRC-41, Accessory Contents of Electronic Equipment Case CY-3885/PRC -41 .....1-6	4-3.	Radio Set AN/PRC-41A, Overall Functional Block Diagram .....4-6
1-4.	Radio Receiver- Transmitter RT-695A/PRC-41, Receiver- Transmitter Case CY-3884/ PRC-41 Displaced .....1-7	4-4.	Radio Receiver-Transmitter RT-695A/PRC-41, Receiver Func- tional Section Block Diagram .....4-13
1-5.	Storage Battery BB-451/U, Oblique View .....1-8	4-5.	Radio Receiver-Transmitter RT- 695A/PRC-41, Transmitter Func- tional Section Block Diagram .....4-25
1-6.	Radio Set AN/PRC-41A, Man-Pack Operation Configuration .....1-9	4-6.	Receive-Transmit Switch, Simplified Schematic Diagram.....4-32
1-7.	Power Supply PP-3700/PRC-41, Oblique View .....1-10	4-7.	Storage Battery BB-451/U, Typical Rate of Discharge .....4-33
1-8.	Mounting MT-2976/PRC-41 and MT-2977/PRC-41, Oblique View .....1-11	4-8.	Power Supply PP-3700/PRC-41, Test Setup .....4-34
1-9.	Antenna AS-1405/PRC-41, Mast AB-777/PRC-41 and Accessories .....1-12	4-9.	Radio Receiver- Transmitter RT-695A/ PRC-41, Power Distribution, Simplified Schematic Diagram.....4-37
1-10.	Antenna Mounting Bracket .....1-13	4-10.	Radio Receiver-Transmitter RT- 695A/PRC-41, Filament Circuits.....4-39
1-11.	Cable Assemblies.....1-13	4-11.	Main Receiver and Transmitter, Functional Section, Frequency Scheme.....4-43
1-12.	Maintenance Cable Kit.....1-14	4-12.	Frequency Selection, Functional Diagram .....4-46
1-13.	Contents of Tool Kit .....1-15	4-13.	Radio Receiver-Transmitter RT-695A/ PRC-44, Receiver, Functional Switching Diagram.....4-49



**LIST OF ILLUSTRATIONS (Cont)**

Figure	Page	Figure	Page
SECTION 4 - TROUBLESHOOTING (Cont)		SECTION 5 - MAINTENANCE (Cont)	
4-14.	Radio Receiver- Transmitter RT- 695A/ PRC-41, Transmitter,Functional Switching Diagram .....4-51	5-25.	RF and Power Amplifier Module, Tuning Capacitor Rotor Tab Z1, Z2, and Z3, Adjustment Diagram ..... 5-32
4-15.	Antenna AS-1405/PRC-41, Azimuthal Plane Voltage Pattern .....4-53	5-26.	RF and Power Amplifier Module, Tuning Capacitor Rotor Tab Z1, Z4, and Z5, Adjustment Diagram ..... 5-32
4-16.	Antenna AS-1405/PRC-41, Voltage  Standing-Wave Ratio.....4-54	5-27.	RF and Power Amplifier Module, Rotor-Stator Coincidence at 225 MHz..... 5-33
4-17.	Antenna AS- 1404/PRC-41, Azimuthal  Voltage Pattern .....4-55	5-28.	1st and 2nd IF Amplifier Module, Switch and Cam Positioning Diagram ..... 5-36
4-18.	Antenna AS-1404/PRC-41, Voltage Standing-Wave Ratio.....4-56	5-29.	RF and Power Amplifier Module, Left Side View, Lubrication Points..... 5-48
4-19.	Radio Set AN/PRC-41A, Functional  Section Servicing Block Diagram.....4-57	5-30.	RF and Power Amplifier Module, Right Side View, Lubrication Points ..... 5-48
SECTION 5 - MAINTENANCE		5-31.	1st and 2nd IF Amplifier Module, Lub- rication Points..... 5-49
5-1.	Junction Box, Schematic Diagram .....5-2	5-32.	Spectrum Generator Module, Lubrica- tion Points ..... 5-49
5-2.	Junction Box, Suggested Layout for Fabrication.....5-2	5-33.	Radio Receiver- Transmitter RT-695A/ PRC-41, Right Side View, Lubrica- tion Points ..... 5-50
5-3.	Examples of Periodic Schedule Charts To Be Prepared for Recording Preventive Maintenance Results.....5-4	5-34.	Radio Receiver- Transmitter RT-695A/ PRC-41, Left Side View, Lubrica- tion Points ..... 5-51
5-4.	Preventive Maintenance Test, D1 and D2.....5-5	5-35.	Radio Set AN/PRC-41A, Parts List Unit Designation..... 5-52
5-5.	Preventive Maintenance Test, W1 .....5-6	5-36.	Radio Set Accessory Kit MK-706/ PRC-41, Parts List Unit Designation ..... 5-52
5-6.	Preventive Maintenance Test, M1 .....5-7	5-37.	Radio Receiver-Transmitter RT-695A/ PRC-41 and Receiver-Transmitter-Case CY- 3884/PRC-41 ..... 5-53
5-7.	Preventive Maintenance Test, M2.....5-8	5-38.	DC Power Supply Module, Oblique View, Parts Location..... 5-53
5-8.	Preventive Maintenance Test, M3.....5-9	5-39.	DC Power Supply Module, Bottom View, Parts Location..... 5-54
5-9.	Preventive Maintenance Test, M4.....5-11	5-40.	1st and 2nd IF Amplifier Module, Wired Bracket, Parts Location ..... 5-55
5-10.	Preventive Maintenance Test, M5.....5-12	5-41.	3rd IF and Squelch Module, Right Side View, Parts Location ..... 5-56
5-11.	Preventive Maintenance Test, M6.....5-13	5-42.	3rd IF and Squelch Module, Left Side View, Parts Location..... 5-57
5-12.	Preventive Maintenance Test, SA1 .....5-14	5-43.	Audio Amplifier Module, Rear View, Parts Location ..... 5-58
5-13.	Preventive Maintenance Test, SA2.....5-15	5-44.	Modulator Module, Front View, Parts Location ..... 5-58
5-14.	Preventive Maintenance Test, SA3.....5-17	5-45.	Guard Receiver Module, Right Side View, Parts Location..... 5-59
5-15.	Preventive Maintenance Test, SA4 and SA5 ..... 5-19	5-46.	Guard Receiver Module, Right Side View, Parts Location..... 5-59
5-16.	Preventive Maintenance Test, SA6 and SA7 ..... 5-20	5-47.	Guard Receiver Module, Left Side View, Parts Location..... 5-60
5-17.	Preventive Maintenance Test, SA8 and SA9 ..... 5-22	5-48.	Guard Receiver Module, Left Side View, Parts Location..... 5-60
5-18.	Preventive Maintenance Test, SA10.....5-24		
5-19.	Preventive Maintenance Test, SA11.....5-25		
5-20.	Preventive Maintenance Test, SA12.....5-26		
5-21.	Radio Receiver-Transmitter RT- 695A/PRC-41, Standard Test Bench Setup ..... 5-28		
5-22.	Main Chassis Couplers in the 225-MHz Position ..... 5-29		
5-23.	Spectrum Generator Module, Tuning Capacitor Rotor Tab Z1, Z2, Z3, Adjustment Diagram ..... 5-30		
5-24.	Spectrum Generator Module, Rotor-Stator Coincidence at 225 MHz..... 5-31		

**LIST OF ILLUSTRATIONS (Cont)**

Figure	Page	Figure	Page
SECTION 5 - MAINTENANCE (Cont)		SECTION 5 - MAINTENANCE (Cont)	
5-49.	Guard Receiver Module, Terminal Board, Parts Location ..... 5-61	5-74.	Directional Antenna Carrying Bracket, Parts Location ..... 5-76
5-50.	RF and Power Amplifier Module, Rear View, Parts Location ..... 5-62	5-75.	1st and 2nd IF Amplifier Module, Exploded View ..... 5-77
5-51.	RF and Power Amplifier Module, Left Side View, Parts Location..... 5-63	5-76.	1st and 2nd IF Amplifier Module, Oscillator and Switchboard Assembly, Exploded View ..... 5-79
5-52.	RF and Power Amplifier Module, Right Side View, Parts Location ..... 5-63	5-77.	1st and 2nd IF Amplifier Module, RF Coil Assembly, Exploded View ..... 5-79
5-53.	Radio Receiver-Transmitter RT-695A/PRC-41, Left Side View, Parts Location ..... 5-64	5-78.	1st and 2nd IF Amplifier Module, Amplifier Subassembly, Exploded View ..... 5-81
5-54.	Radio Receiver-Transmitter RT 695A/PRC-41, Front Panel, Parts Location ..... 5-65	5-79.	Spectrum Generator Module, Exploded View ..... 5-82
5-55.	Receiver-Transmitter Case CY-3884/ PRC-41, Inside View, Parts Location ..... 5-66	5-80.	RF and Power Amplifier Module, Exploded View ..... 5-83
5-56.	Power Supply PP-3700/PRC-41, Dust Cover Displaced, Parts Location ..... 5-66	5-81.	Radio Receiver-Transmitter RT-695A/PRC-41, Main Chassis, Exploded View ..... 5-84
5-57.	Power Supply PP-3700/PRC-41, Bottom View, Dust Cover Removed, Parts Location..... 5-67	5-82.	AF Amplifier Assembly (Buffer) ..... 5-85
5-58.	Power Supply PP-3700/PRC-41, Side View, Dust Cover Removed, Parts Location ..... 5-67	5-83.	Connector and Filter Assembly ..... 5-85
5-59.	Power Supply PP-3700/PRC-41, End View, Dust Cover Removed, Parts Location ..... 5-68	5-84.	Receive-Transmit Switch, Exploded View ..... 5-86
5-60.	Power Supply PP-3700/PRC-41, Oblique View, Parts Location..... 5-68	5-85.	Special Purpose Electrical Cable Assembly CX-10831/PRC-41A..... 5-86
5-61.	Power Supply PP-3700/PRC-41, Side View, Dust Cover Removed, Parts Location..... 5-69	5-86.	Power Supply PP-3700/PRC-41, Schematic Diagram ..... 5-87
5-62.	Antenna AS-1405/PRC-41, Parts Location ..... 5-69	5-87.	DC Power Supply 1A1, Schematic Diagram..... 5-89
5-63.	Mounting MT-2965/PRC-41, Parts Location..... 5-70	5-88.	1st and 2nd IF Amplifier 1A2, Schematic Diagram..... 5-91
5-64.	Mounting MT-2976/PRC-41, Rear View, Parts Location ..... 5-70	5-89.	3rd IF and Squelch 1A3, Schematic Diagram..... 5-93
5-65.	DC Adapter Cable, Parts Location..... 5-71	5-90.	Audio 1A4, Schematic Diagram. .... 5-95
5-66.	Cable Assemblies, Parts Location ..... 5-71	5-91.	Spectrum Generator 1A5, Schematic Diagram..... 5-97
5-67.	Mast AB-777/PRC-41, Parts Location ..... 5-72	5-92.	Modulator 1A6, Schematic Diagram ..... 5-99
5-68.	Adjustable Antenna Mast Adapter, Parts Location..... 5-72	5-93.	Guard Receiver 1A7, Schematic Diagram..... 5-101
5-69.	Mounting MT-2977/PRC-41, Parts Location ..... 5-73	5-94.	RF and Power Amplifier 1A8, Schematic Diagram..... 5-103
5-70.	Rucksack Frame and Harness ..... 5-73	5-95.	Radio Set AN/PRC-41A, Interconnection Diagram ..... 5-104
5-71.	Antenna Mounting Bracket, Parts Location ..... 5-74	5-96.	Radio Receiver-Transmitter RT-695A/PRC-41, Main Chassis, Wiring Diagram ..... 5-106
5-72.	Maintenance Cable Set, Parts Location ..... 5-75	5-97.	Electrical Wire Code ..... 5-107
5-73.	DC Maintenance Adapter, Parts Location ..... 5-76	5-98.	Radio Set AN/PRC-41A, Schematic Diagram ..... 5-109
		5-99.	Mounting MT-2976/PRC-41, Wiring Diagram and Schematic Diagram..... 5-115

**LIST OF TABLES**

Table	Page	Table	Page
SECTION 1 - GENERAL INFORMATION		SECTION 5 - MAINTENANCE	
1-1.	Radio Set AN/PRC-41A, Equipment Supplied.....1-1	5-1.	Reference Standards Procedures..... 5-3
1-2.	Radio Set Accessory Kit MK-706/ PRC-41, Equipment Supplied.....1-2	5-2.	DC Power Supply Module, Voltage Measurements ..... 5-43
1-3.	Equipment Required But Not Supplied .....1-3	5-3.	1st and 2nd IF Amplifier Module, Voltage Measurements ..... 5-43
1-4.	Contents of Maintenance Cable Kit.....1-16	5-4.	3rd IF and Squelch Module, Voltage Measurements ..... 5-43
1-5.	Contents of Tool Kit .....1-17	5-5.	Audio Module, Voltage Measurements ..... 5-44
SECTION 4 - TROUBLESHOOTING		5-6.	Spectrum Generator Module, Voltage Measurements ..... 5-44
4-1.	How to Avoid Damage to Transistors.....4-3 While Servicing Circuits ....	5-7.	Spectrum Generator Module, Resistance Measurements..... 5-44
4-2.	Test Points.....4-7	5-8.	Modulator Module, Voltage Measurements ..... 5-44
4-3.	Overall Trouble Isolation.....4-10	5-9.	Guard Receiver Module, Voltage Measurements ..... 5-45
4-4.	Main Receiver Functional Section, Trouble Isolation .....4-16	5-10.	RF and Power Amplifier Module, Voltage Measurements ..... 5-45
4-5.	Guard Receiver Functional Section, Trouble Isolation.....4-22	5-11.	RF and Power Amplifier Module, Resistance Measurements ..... 5-46
4-6.	Transmitter Functional Section, Trouble Isolation4-8	5-12.	Radio Receiver-Transmitter RT 695A/PRC-41, Main Chassis Voltage Measurements ..... 5-46
4-7.	AF Amplifier Assembly (Buffer) Circuits, Trouble Isolation .....4-31	5-13.	Power Supply PP-3700/PRC-41, Normal Voltage Measurements..... 5-46
4-8.	Power Supply PP-3700/PRC-41, Trouble Isolation .....4-35	5-14.	Power Supply PP-3700/PRC-41, Overload Trip Voltage Measurements..... 5-46
4-9.	Power Distribution Circuits .....4-40	5-15.	Lubrication Instructions ..... 5-47
4-10.	Frequency Generation, Circuit Trouble Isolation ..... 4-45	SECTION 6 - PARTS LIST	
		6-1.	List of Units ..... 6-2
		6-2.	Maintenance Parts List..... 6-3
		6-3.	List of Manufacturers ..... 6-51

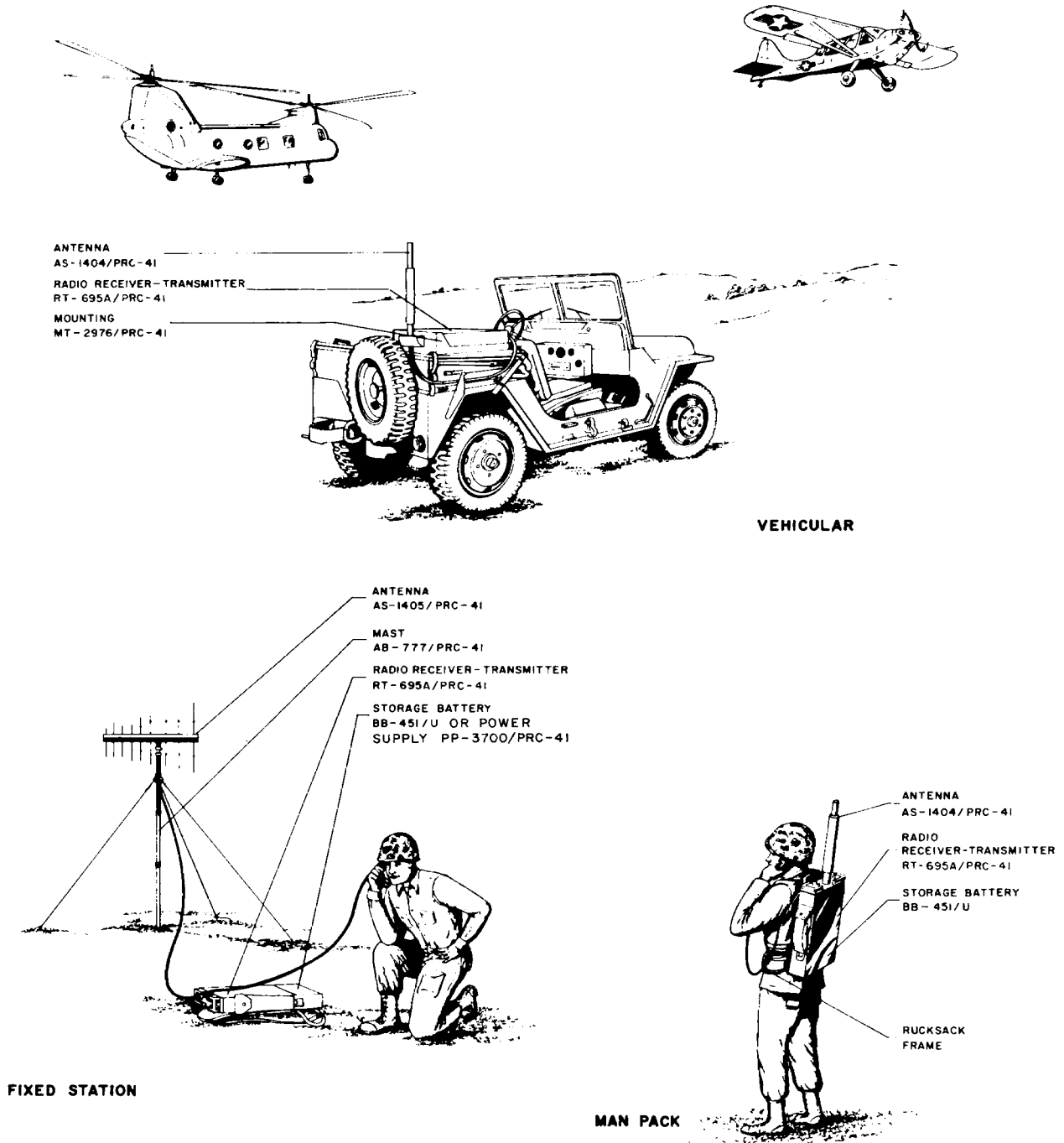

Figure 1-1. Radio Set AN/PRC-41A, Operating Configuration

**SECTION 1**

**GENERAL INFORMATION**

**1-1. SCOPE.**

Information applicable to Radio Set AN/PRC-41A is contained in the Installation and Operation Technical Manual for Radio Set AN/PRC-41A NavShips 0967-872-5010 and the Repair and Maintenance Technical Manual for Radio Set AN/PRC-41A NavShips 0967-872-5020. The format and content of these manuals is in accordance with the requirements of Military Specification MIL -M - 15071 F (SHIPS) and contract N00039-69-C-3511. The installation and operation technical manual includes sections 1, 2, and 3. The repair and maintenance technical manual includes sections 1, 4, 5, and 6. These manuals are applicable to the items and accessories of Radio Set AN/PRC-41A. Section 1 contains a general description, provides reference data, lists the applicable items and accessories, and provides information required for the preparation for reshipment of the Radio Set AN/PRC-41A equipment. Section 2 provides installation information such as unpacking, power requirements for operation, site selection, inspection and adjustment, and interference reduction. Section 3 contains operating instructions. Section 4 provides theoretical description and test data of the functional sections and subordinate circuits of the equipment. Section 5 provides preventive maintenance instructions, repair information, and illustrations which are applicable to all sections such as part location, exploded views, connection diagrams, and overall equipment schematics. Section 6 lists the detail parts of the items and accessories of Radio Set AN/PRC-41A. These technical manuals are in effect upon receipt. Extracts from these publications may be made to facilitate the preparation of other Department of Defense publications.

**1-2. EQUIPMENT SUPPLIED.**

Radio Set AN/PRC-41A consists of the equipment contained in Radio Set Case CY-3883/PRC-41. Refer to table 1-1 and figure 1-2. Radio Set Accessory Kit MK-706/PRC-41 consists of the equipment contained in Electronic Equipment Case CY-3885/PRC-41. Refer to table 1-2 and figures 1-1 and 1-3.

**1-3. EQUIPMENT REQUIRED BUT NOT SUPPLIED.**

The equipment required for maintenance of Radio Set AN/PRC-41A is listed in table 1-3.

**TABLE 1-1. RADIO SET AN/PRC-41A, EQUIPMENT SUPPLIED**

ITEM	QTY	NOMENCLATURE		OVERALL DIMENSIONS (in)			VOL (in <sup>3</sup> )	WT (lb)
		NAME	DESIGNATION	H	W	D		
1	1	Radio set case (less contents)	CY-3883/PRC-41	15-1/2	35	26-1/2	14,376	82.5
2	1	Radio receiver-transmitter (without case (CY-884/PRC-41)	RT-695A/PRC-41	14	11-5/16	4-9/16	812	18.5
3	1	Receiver-transmitter case	CY-3884/PRC-41	12-5/8	11-3/16	4-15/32	635	3.6
4	3	Storage battery	BB-451/U	7-11/16	11-9/16	4-9/64	402	16.0
5	1	Antenna	AS-1404/PRC-41	23-1/2	1-3/4 dia			.07
6	1	Handset	H-33E/PT (GFE)	2	8	3-3/8		1.2
7	1	Rucksack frame	(GFE)	19	17	6-1/4		1.5
8	1	Harness set						3.1
9	2	Installation and operation technical manual	NavShips 0967-872-5010 TM-03816B-12/1 TM-11-5820-510-12-1	8-1/2	11	1-1/2		

NAVSHIPS 0967-872-5020  
TM-03816B-35/2  
TM11-5820-510-35-1

**TABLE 1-1. (Continued)**

ITEM	QTY	NOMENCLATURE		OVERALL DIMENSIONS			VOL (in <sup>3</sup> )	WT (lb)
		NAME	DESIGNATION	H	W	D		
10	2	Repair and Maintenance technical manual with repair part list	NavShips 0967-872-5020 TM-03816B-35/2 TM11-5820-510-35-1	8-1/2	11	1-3/4		
11	1	Special purpose electrical cable assembly	CX-10831/PRC-41A	24				

**TABLE 1-2. RADIO SET ACCESSORY KIT MK-706/PRC-41, EQUIPMENT SUPPLIED**

ITEM	QTY	NOMENCLATURE		OVERALL DIMENSIONS (in)			VOL (in <sup>3</sup> )	WT (lb)
		NAME	DESIGNATION	H	W	D		
1	1	Electronic equipment case (less contents)	CY-3885/PRC-41	15-1/2	35	26-1/2	14,376	81.0
2	1	Power Supply	PP-3700/PRC-41	7-47/64	10-15/16	4-5/32	355	17.6
3	1	Antenna	AS-1405/PRC-41	3-1/2	30-27/32	27-11/16		6.3
4	1	Mast	AB-777/PRC-41	78-1/4 28-1/4	3-1/2 open 3-1/2 closed			3.0
5	1	Adjustable antenna mast adapter		10-3/4				1.0
6	1	Antenna mounting bracket		4-13/16	8-5/8	1-7/8		0.7
7	1	Directional antenna carrying		1*-23/32	31-17/32	1-3/4		4.8
8	3	Guy rope accessory		10 ft				1.5
9	3	Guy stake		10	1	1		2.1
10	1	Bag (for guy stake)		12	5			0.1
11	1	Mounting	MT-2976/PRC-41	6-1/8	17-3/4	11-13/16	1230	6.6
12	1	Mounting	MT-2977/PRC-41	17/32	11-1/2	5-3/8	31	2.1
13	1	Radio frequency cable assembly	CG-55g/U	20 FT				2.4
14	1	Power electric cable assembly	CX-8686/PRC-41	10 ft				2.8
15	1	Power electric cable assembly	CX-8687/PRC-41	50 ft				5.4
16	1	Special purpose electrical cable assembly	CX-8688/PRC-41	10 ft				1.0
17	1	Dc adapter cable		27				0.3
18	1	Maintenance cable kit		12	5			
19	1	Tool kit		7-1/4	3-1/2			0.8

\*Unless otherwise stated, all overall dimensions are in inches.

**TABLE 1-3. EQUIPMENT REQUIRED BUT NOT SUPPLIED**

QTY PER EQUIP	NOMECLATURE		REQUIRED USE	RADIO SET AN/PRC-41
	NAME	DESIGNATION		
1	Signal generator	AN/USM-44A or AN/URM-26B	Guard and main receiver functional section troubleshooting and maintenance procedures	Frequency range: 225 to 400 MHz. Type of signal: AM. Modulation: 1000 Hz internal with external provisions
1	Signal generator	AN/URM-25D	Troubleshooting and maintenance procedures	Frequency range 10 Hz to 50 MHz. Type of signal: AM Output voltage: 0.1 to 100,000 microvolts .
1	Rf wattmeter	AN/URM-43C or TS-1389	Power output measurements	Power output: 0 to 5 watts. Impedance: 50 ohms.
1	Oscilloscope	AN/USM-105A	Troubleshooting and maintenance procedures.	General purpose.
1	Output power meter or Output meter or Output meter	ME-2/U or ME-184 or TS-585B/U or ME-6C/U	Audio output measurements.	Power output: 0 to 1 watt. Impedance: 300 ohms.
1	Audio oscillator	TS-382B/U or AN/URM-127	Troubleshooting and maintenance procedures.	Frequency: 100 to 20,000 Hz. Output: 0 to 2 volts.
1	Fuse	MX-1730/U (p/o AN/USM-44)	Attenuator protection for signal generator.	Rf fuse: 225-to 400-MHz range.
1	Multimeter	AN/PSM-4C	Troubleshooting and maintenance procedures.	Voltage ranges: 0 to 250 volts dc. 0 to 250 volts ac, ohmmeter section.
1	Electronic multimeter	TS-505/U or AN/USM-116	Troubleshooting and maintenance procedures	Voltage ranges: 0 to 250 volts dc. 0 to 250 volts ac, ohmmeter section.
1	Frequency counter	AN/USM-122 or CAQI-524D	Frequency measurement to extend the frequency	
1	Electronic frequency converter	CV-394/USA-5 or CAQI-525C	Used with AN/USM-122 measuring capabilities.	Measure frequencies in 20-to 30-MHz and 225- to 400-MHz ranges.
1	Transfer oscillator	CM-102/USM-73	Used with AN/USM-122 to extend the frequency measuring capabilities.	
1	Adjustable attenuator	CN-318/G or CAG-874-GA	An attenuator and T-connector used for modulation and signal measurements.	Rf attenuator to provide attenuation for high-level outputs.

ORIGINAL

**TABLE 1-3. (Continued)**

QTY PER EQUIP	NOMENCLATURE		REQUIRED USE	RADIO SET AN/PRC-41 EQUIPMENT CHARACTERISTICS
	NAME	DESIGNATION		
1	Signal generator pad	CN-315/URM-26 (p/o AN/URM- 26B) or C BSH-50-6	Used for impedance matching between signal generator and radio equipment,	Pad attenuation: 6 db. Impedance: 50-ohm input and output. Frequency range: 225 to 400 MHz.  Variable 0- to 20-ohm resistor, 100 watt.    Rf crystal for detection of modulated rf signals.
1	Power resistor	240C	Used for loading Power Supply PP-3700/PRC-41 when performing tests.	
	Transistor test set	TS-110GA/U	Used for checking transistors.	
1	Electron tube test set	TV-7D/U	Used for checking electron tubes.	
1	Coaxial crystal detector	HP-420A (Hewlett-Packard)		
1	Junction box	To be fabricated. Refer to section 5		
1	Battery charger	PP-3240/U, PP-4567/U, PP-6241/U.	Used for charging radio battery.	

**1-4. GENERAL DESCRIPTION.**

Radio Set AN/PRC-41A is a lightweight, portable uhf receiver-transmitter equipment. The versatility of this equipment permits man-pack, fixed station, or vehicular operation. See figure 1-1. The items and accessories of AN/PRC-41A and Accessory Kit MK-706/PRC-41A are listed in tables 1-1 and 1-2. This equipment is stored for transit in Radio Set Case CY-3883/PRC-41 and Electronic Equipment Case CY-3885/PRC-41. See figures 1-2 and 1-3. CY-3883/PRC-41 contains the items necessary for man-pack operation. CY-3885/PRC-41 contains the accessory items required for fixed station or vehicular operation, and maintenance items such as tools and extension cables. Radio Receiver-Transmitter RT-695A/PRC-41 of AN/PRC-41A may be operated on any one of 1750 channels, spaced 100kHz in the 225.0-to 399.9-MHz range. In transmit operation, the equipment uses type a3 (AM voice) emission and provides an average of at least 3 watts of power across the frequency range. All controls are an integral part of the front panel of RT-695A/PRC-41. These controls provide frequency selection, application of power, and adjustment of volume and squelch levels. Automatic relay operation in normal voice mode may be provided when two RT-695A/PRC-41 equipments are operated together. Cabling is provided for all modes of operational installations. RT-695A/PRC-41 has the capability of secure voice operation when used in conjunction with TSEC/KY-38 equipment. Primary power may be provided by either Storage Battery BB-451/U, Power Supply PP -3700/PRC -41, or vehicular battery supply. The equipment may use Antenna AS-1405/PRC-41 (directional) or Antenna AS-1404/ PRC-41 (omnidirectional).

**1-5. DESCRIPTION OF UNITS.**

**a. GENERAL.** - Radio Set AN/PRC-41A consists of Radio Set Case CY-3883/PRC-41 and its contents. Refer to figure 1-2. Radio Set Accessory Kit MK-706/PRC -41 consists of Electronic Equipment Case CY-3885/PRC-41 and its contents. Refer to figure 1-3. The following paragraphs provide physical, electrical, and functional descriptions of the case and contents of Radio Set Case CY-3885/PRC-41 and Electronic Equipment Case CY-3885/PRC-41.

**b. RADIO SET AN/PRC-41A.**

(1) RADIO SET CASE CY-3883/PRC-41. Radio Set Case CY-3883/PRC-41 is an aluminum transit case with a foam rubber compartmentalized insert used for storage of the items of AN/PRC-41A



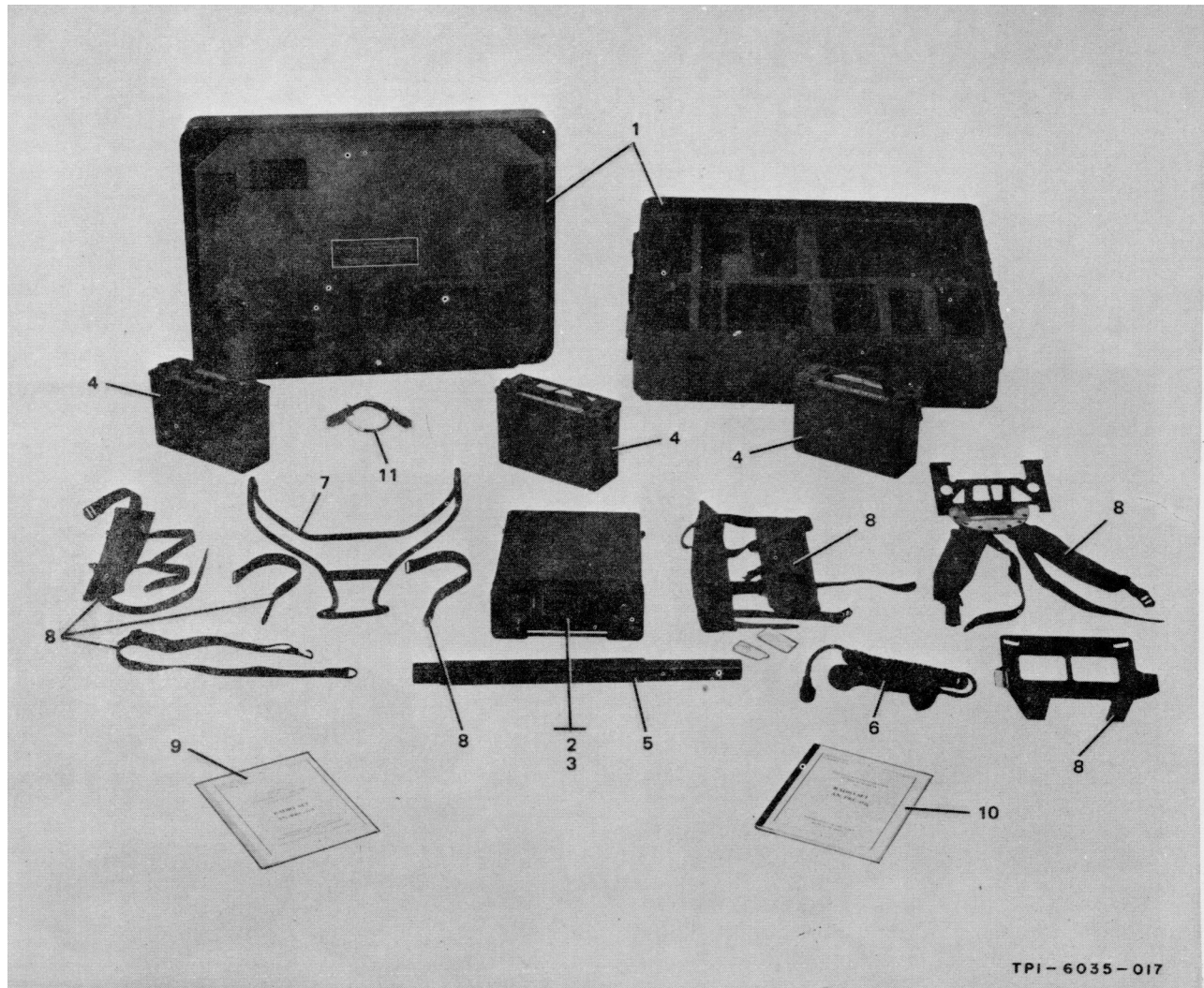

Figure 1-2. Radio Set AN/PRC-41A, Equipment Contents of Radio Set Case CY-3883/PRC-41

that are required for man-pack operation. It measures 15-1/2 by 35 by 26-1/2 inches and weighs 45 pounds. Refer to figure 1-2.

(2) RADIO RECEIVER-TRANSMITTER RT695A/PRC-41. Radio Receiver-Transmitter RT695A/PRC-41 consists of a main chassis with eight plug-in modules, a control panel, and a waterproof dust cover (Receiver-Transmitter Case CY-3884/ PRC-41). Refer to figure 1-4. The modules can be removed from the main chassis by loosening captive screws on each module. All electrical connections between the modules and the main chassis are made through multipin connectors on each module to jacks mounted on the main chassis. The coaxial cables and the connectors, that are integral with the multipin connectors except for the power amplifier output, conduct the rf signals between the plug-in modules. Mechanical coupling for tuning functions is achieved by a mechanical gear train and couplers mounted on the main chassis, and the couplers of the mechanically tuned modules. The main chassis gear train is driven by the frequency selector controls on the front panel. Pressure contacts located at the rear of the main chassis, provide the electrical connections to the CY-3884/PRC-41 for supplying the primary 26.5-volt dc supply from either Storage Battery BB-451/U or Power Supply PP-3700/PRC-41. A coaxial connector, located on the front panel mates with Antenna AS-

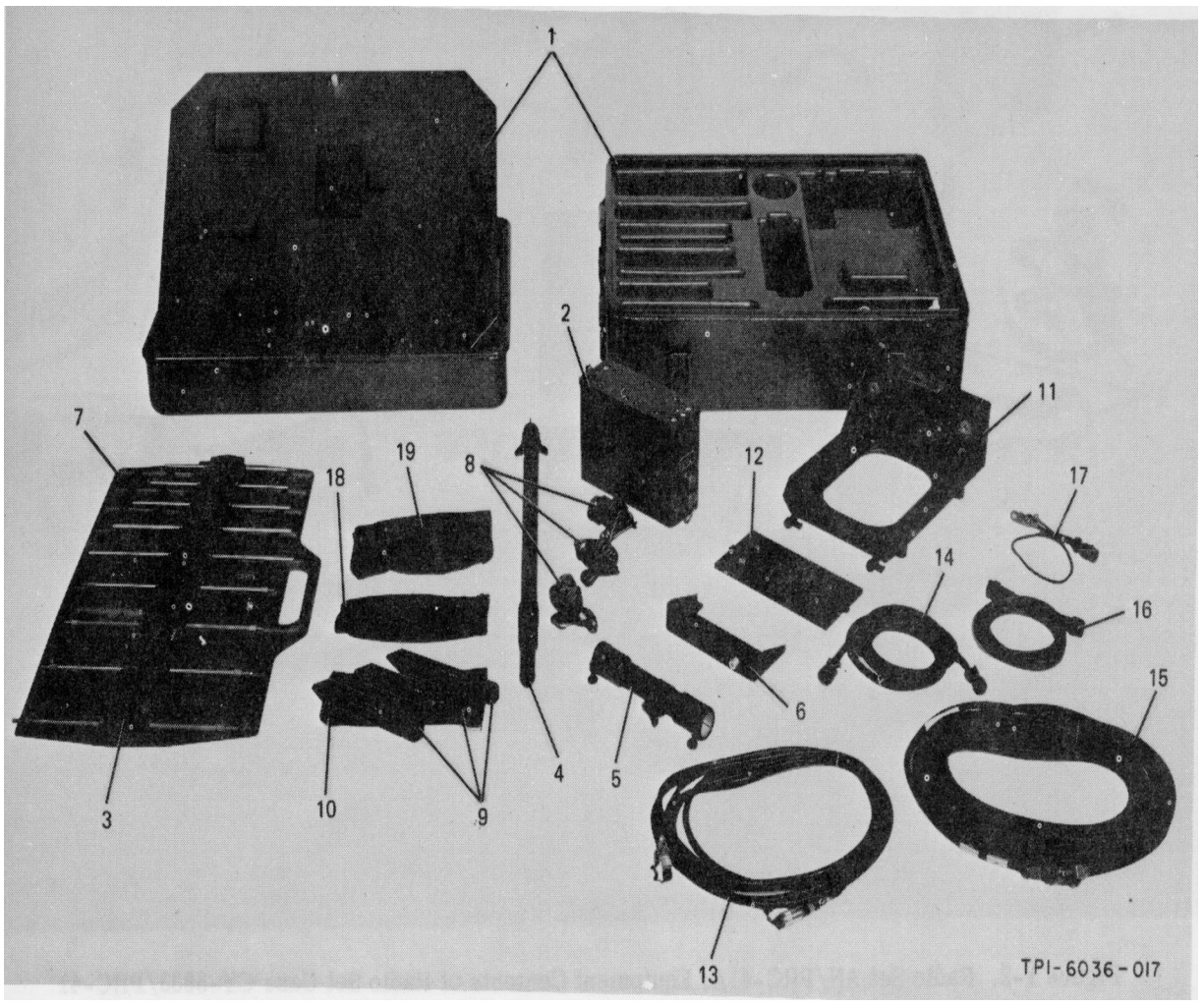

Figure 1-3. Radio Set Accessory Kit MK-706/PRC-41, Accessory Contents of Electronic Equipment Case CY-3885/PRC-41

1404/PRC-41 (omnidirectional) or with Radio Frequency Cable Assembly CG-55G/U when using Antenna AS-1405/PRC-41 (directional). The front panel also mounts a function switch, for application of power, volume control, squelch control, three frequency selector controls, a window which indicates the frequency to which the equipment is tuned, one audio connector for Handset H-33E/PT, and one connector to provide interface with TSEC/KY-38 security equipment.

(3) RECEIVER-TRANSMITTER CASE CY-3884/PRC-41. Receiver-Transmitter Case CY-3884/PRC-41 is a dust cover for Radio Receiver-Transmitter RT-695A/PRC-41. Refer to figure 1-4. The CY-3884/PRC-41 is secured to the RT-695A/PRC-41 by four captive screws which are located at the rear of the CY-3884/PRC-41. With the CY-3884/PRC-41 in place on the RT-695A/PRC-41, primary power is applied through pressure contacts located at the rear corners to the contacts centrally located on the inside rear of the CY-3884/PRC-41. The power is then available to the pressure contacts at the rear of the main chassis and then to the power distribution circuits of the RT-695A/PRC-41.

(4) STORAGE BATTERY BB-451/U. (Refer to figure 1-5.)

(a) GENERAL. Storage Battery BB451/U is a silver-zinc alkaline 24-volt (nominal) rechargeable storage battery. It is used to provide primary power to RT-695A/PRC-41 in a man-pack operation or where no other suitable

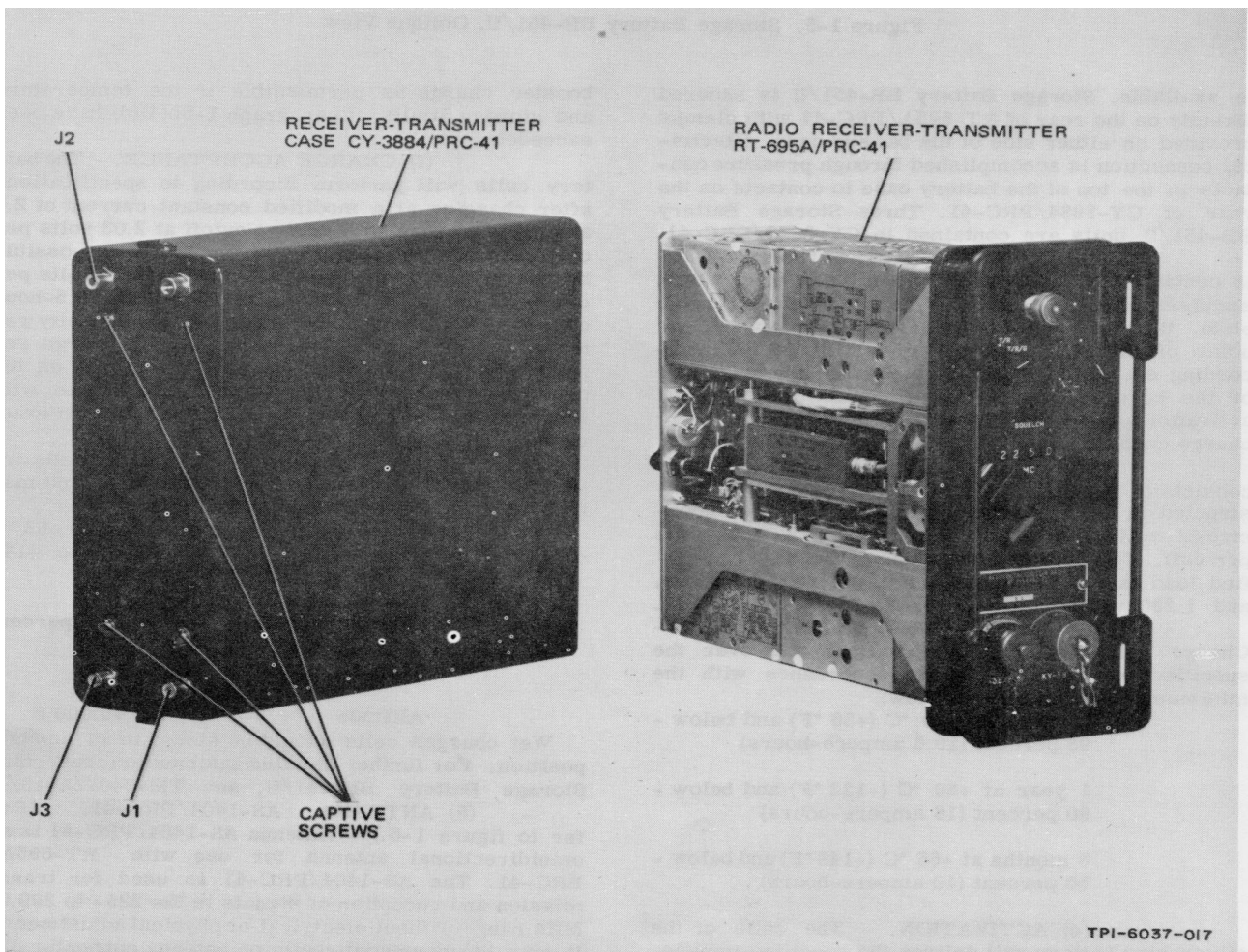

Figure 1-4. Radio Receiver-Transmitter RT-695A/PRC-41, Receiver-Transmitter Case CY-3884/PRC-41 Displaced

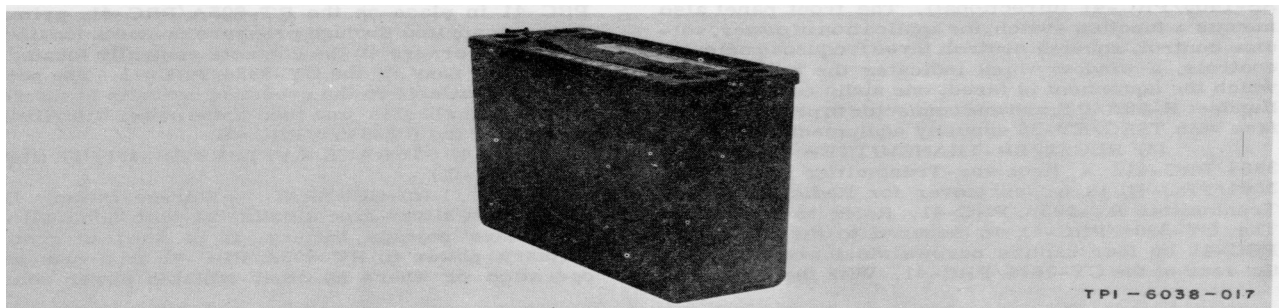

Figure 1-5. Storage Battery BB-451/U, Oblique View

is available. Storage Battery BB-451/U is secured directly on the rear of RT-695A/PRC-41 with clamps provided on either side of the battery case. Electrical connection is accomplished through pressure contacts in the top of the battery case to contacts on the rear of CY-3884/PRC-41. Three Storage Battery BB-451/U units are contained in CY-3883/PRC-41.

(b) CONSTRUCTION. - The BB-451/U is contained in a watertight fiber glass case with a stainless steel cover plate. After removing the cover plate, the cells may be removed in groups of four using ordinary hand tools. A plastic sheet for recording charging history is bonded to the underside of the cover plate. To avoid a long formation and activation period, the BB-451/U is supplied in a dry charge condition.

(c) CELLS. - The BB-451/U battery consists of 16 series-connected silver-zinc cells constructed in blocks of four cells each. Nominal open-circuit voltage of a fully charged cell is 1.86 volts per cell. The minimum voltage per cell under specified load is 1.375 volts at -11 °C (+12 °F) and above, and 1.250 volts from -10 to -25 °C (+14 to -13 °F).

(d) CHARGE RETENTION (DRY). Charge retention of a dry charged cell over the specified periods will be in accordance with the minimum values indicated below:

2 years at +30 °C (+86 °F) and below -98 percent (19.6 ampere-hours)

1 year at +50 °C (+122 °F) and below -80 percent (16 ampere-hours)

3 months at +65 °C (+149 °F) and below -50 percent (10 ampere-hours)

(e) ACTIVATION. - The cells of the silver-zinc battery will deliver the specified ampere-hour capacity after a 24-hour soak in the electrolyte, a 40-percent solution of potassium hydroxide and other additives furnished by the manufacturer. A booster charge is permissible if the temperature and storage limits of paragraph 1-5b(4)(d) have been exceeded.

(f) CHARGE ACCEPTANCE. The battery cells will perform according to specifications after charging at a modified constant current of 2.5 amperes average with voltage cutoff at 2.03 volts per cell. Emergency charging of the cells is possible by charging at a constant potential of 2.03 volts per cell with charge acceptance as follows: a 0.5-hour charge period replaces 50 percent of the capacity removed on previous discharge; a 4-hour charge replaces 60 percent of the capacity removed on the previous discharge. All recharging must be with Battery Charger PP-3240/U, PP-3906/U, or an exact replacement.

(g) STORAGE. - Dry charged cells are filled with an inert gas by the manufacturer and may be stored under the following conditions:

Temperature range -65 to +65 °C (-85 to +149 °F)

Relative humidity 100 percent

Attitude Any

Altitude 40,000 ft

Wet charged cells should be stored in an upright position. For further detailed information concerning Storage Battery BB-451/U, see TM-04072A-15/1.

(5) ANTENNA AS-1404/PRC-41. (Refer to figure 1-6.) - Antenna AS-1404/PRC-41 is an omnidirectional antenna for use with RT-695A/ PRC-41. The AS-1404/PRC-41 is used for transmission and reception of signals in the 225- to 399.9-MHz range without electrical or physical adjustments. It may be mounted directly on antenna connector J28 on the front panel of RT-695A/PRC-41 or the connector on the antenna mounting bracket on Mounting MT-2976/ PRC-41 or, when mounted on Mast AB-777/PRC-41, it must be connected through Adapter UG-29B/U and Radio Frequency Cable Assembly CG-55G/U to the RT-695A/PRC -41.

(6) HANDSET H-33E/PT. (Refer to figure1-6.) - Handset H-33E/PT consists of a handpiece a length of cable, and a connector that mates with the H33E/PT connector J13 on the front panel of RT-695A/PRC-41. The H-33E/PT contains a carbon microphone, an electromagnetic earphone, and a press-to-talk button. In operation, pressing the press-to-talk button places the RT-695A/PRC-41 equipment in transmit operation; releasing the button returns the equipment to receive operation.

(7) RUCKSACK FRAME. (Refer to figure1-6.) - The rucksack frame is government furnished equipment. The rucksack frame and associated straps and harness provide a back-pack frame for carrying Radio Receiver-Transmitter RT-695A/PRC-41, Storage Battery BB-451/U, Handset H-33E/PT, and Antenna AS-1404/PRC-41 in man-pack operation.

(8) SPECIAL PURPOSE ELECTRICAL CABLE ASSEMBLY CX-10831/PRC-41A. (Refer to figure 1-3.) - The CX-10831/PRC-41A is a 2-footlength of 7-conductor cable with suitable mating connectors. It is used to connect RT-695A/PRC-41 to the TSEC/ KY-38 security equipment.

c. RADIO SET ACCESSORY KIT MK-706/ PRC-41.

(1) ELECTRONIC EQUIPMENT CASE CY3885/PRC-41.-Electronic Equipment

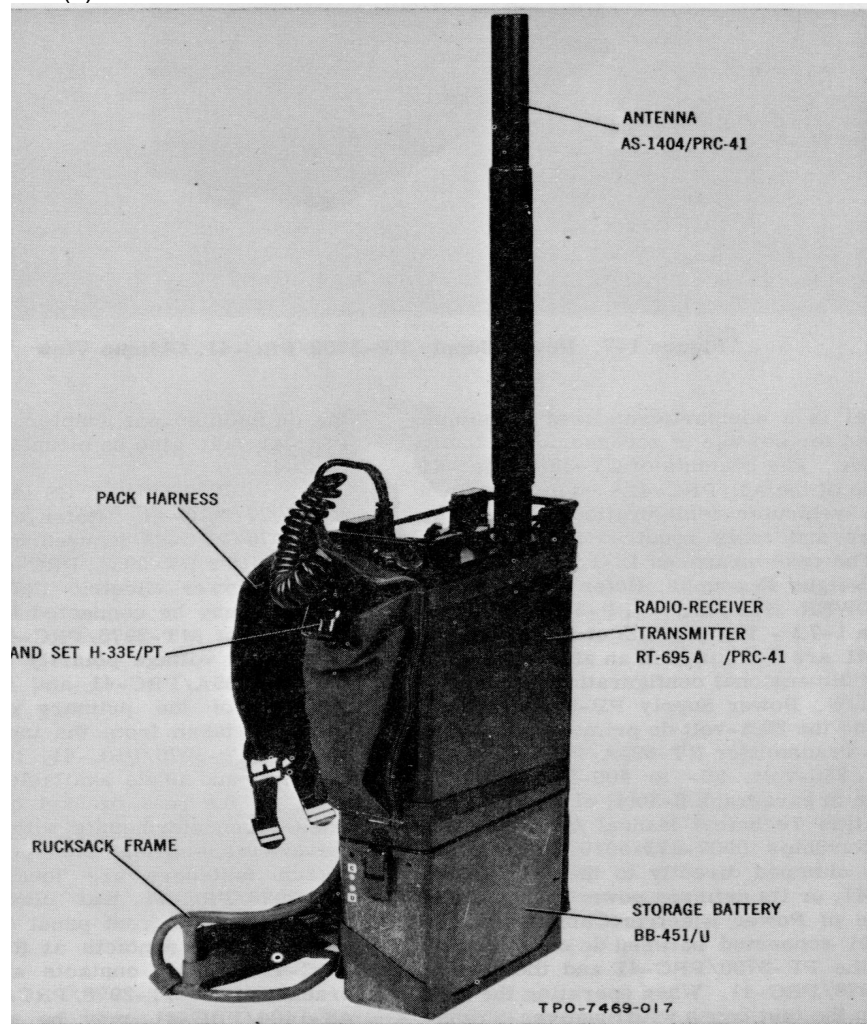

Figure 1-6. Radio Set AN/PRC-41A, Man-Pack Operation Configuration

ORIGINAL

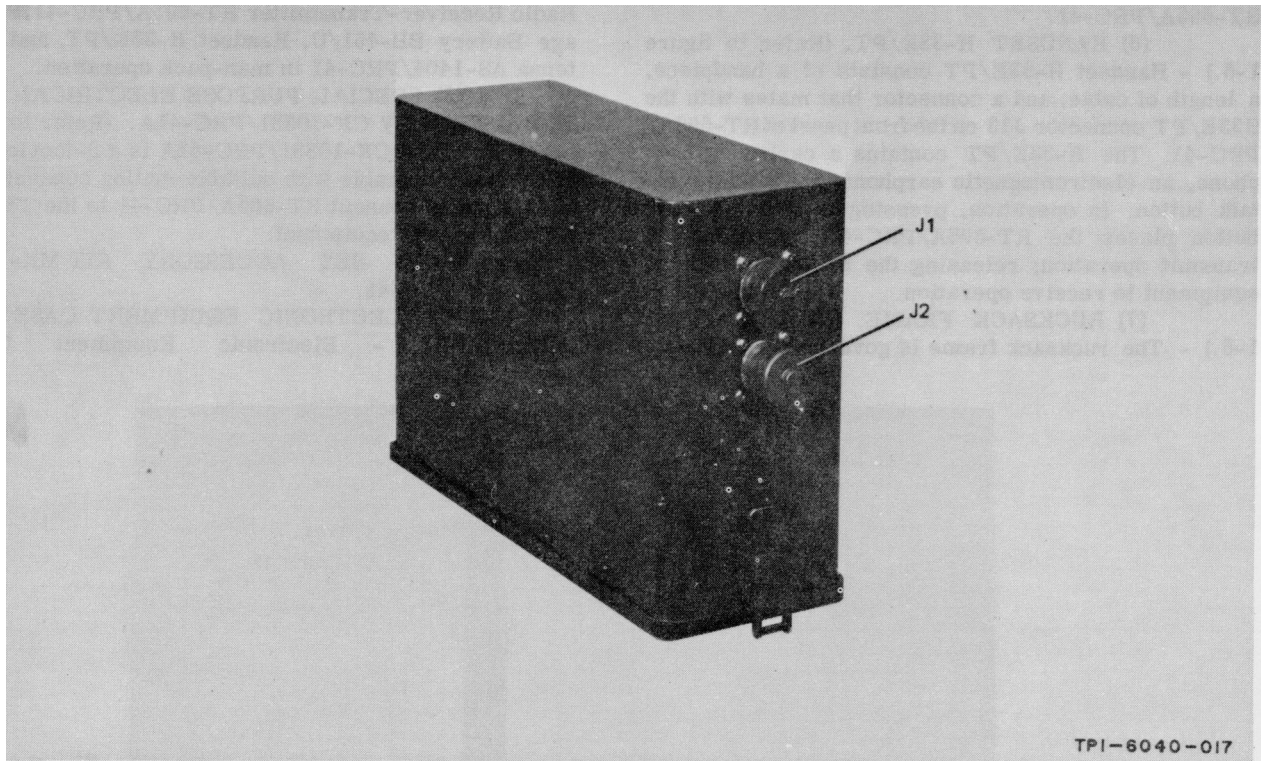

Figure 1-7. Power Supply PP-3700/PRC-41, OBLIQUE VIEW

Case CY-3885/PRC-41 is a compartmentalized aluminum transit case used for storage of accessories of Radio Set AN/PRC-41A. The contents of CY-3885/PRC-41 permit operation of the AN/PRC-41A equipment in a fixed station or vehicular configuration, and provide extension cables and tools required for equipment maintenance. The case measures 15-1/2 by 35 by 26 1/2 inches and weighs 45 pounds. Refer to figure 1-3.

(2) POWER SUPPLY PP-3700/PRC-41. (Refer to figure 1-7.) - The circuits of Power Supply PP-3700/PRC-41 are contained in an aluminum case having the same dimensional configuration as Storage Battery BB-451/U. Power Supply PP-3700/PRC-41 is used to provide the 26.5-volt dc primary power for Radio Receiver-Transmitter RT-695A/PRC-41 where either 115- or 230-volt, 50- to 400-Hz power is available. Refer to paragraph 2-5b(1) of the Installation and Operation Technical Manual for Radio Set AN/PRC-41A, NavShips 0967-872-5010. This component may be clamped directly to the rear of the RT-695A/PRC -41, or its primary power may be made available by use of Power Electric Cable Assembly CX-8686/PRC-41 connected between dc connector J2 on the side of the PP-3700/PRC-41 and the rear of Mounting MT-2976/PRC-41. When operating the RT695A/PRC-41 on the test bench with Receiver-Transmitter Case CY-3884/PRC-41 removed, primary power may be applied to the RT-695A/PRC-41 through the dc maintenance adapter. Power Supply PP-3700/ PRC-41 may also be mounted on Mounting MT-2977/ PRC -41.

(3) MOUNTINGS MT-2976/PRC-41 AND MT-2977/PRC-41. (Refer to figure 1-8.) - Mounting MT-2976/PRC-41 is used to mount Radio Receiver-Transmitter RT-695A/PRC-41 in a vehicular installation. Power Electric Cable Assembly CX-8686/ PRC-41 may be connected to the input connector at the rear of MT-2976/PRC-41 that contains circuits to prevent voltage polarity reversal from damaging the RT-695A/PRC-41 and filter circuits for input filtering of the primary power voltage. Primary power is taken from the input connector at the rear of the MT-2976/PRC -41, fed through the mounting circuits, and made available to the connectors at the front of the rear bracket of the MT-2976/PRC-41. These connectors mate with those at the rear of Receiver-Transmitter Case CY-3884/PRC-41. Two takeup fasteners are located at the front of the MT-2976/PRC-41 that clamp over the protection handles on the front panel of the RT-695A/PRC-41 and hold the contacts at the rear of the CY-3884/ PRC-41 to the contacts at the front of the rear bracket of the MT-2976/PRC -41. A mount for Antenna AS-1404/PRC-41 may be secured on the rear of MT-2976/PRC-41 for vertical positioning of the antenna when the RT-695A/PRC -41 and MT-2976/PRC-41

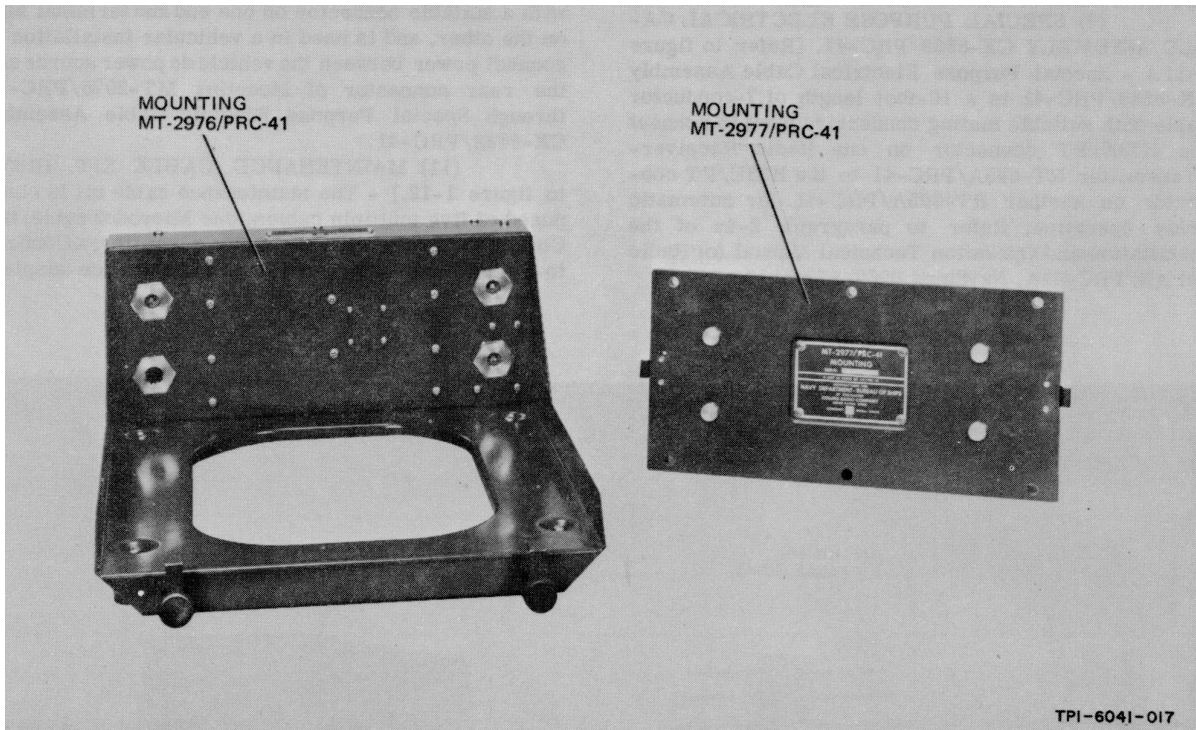

Figure 1-8. Mounting MT-2976/PRC-41 and MT-2977/PRC-41, Oblique View

are installed in a horizontal position on a vehicle. Mounting MT-2977/PRC-41 is used normally in a fixed station installation for mounting Power Supply PP-3700/PRC-41.

(4) ANTENNA AS-1405/PRC-41 AND ACCESSORIES. (Refer to figure 1-9.) -Antenna AS-1405/PRC-41 is a directional antenna for use with Radio Receiver-Transmitter RT-695A/PRC-41. The AS-1405/PRC-41 is used for transmission and reception of signals in the 225- to 399.9-MHz range. The elements of AS-1405/PRC-41 are made collapsible for storage but are extended to the maximum length for use in the 225- to 399.9-MHz range. Refer to figure 1-9. The AS-1405/PRC-41 is a planar log periodic dipole array that provides unidirectional radiation characteristics, and mounts on an adjustable antenna mast adapter and Mast AB-777/PRC-41. Guy ropes and stakes permit AB-777/PRC-41 to be staked in place in a fixed station installation. The adjustable antenna mast adapter permits elevation orientation of AS-1405/PRC-41. Radio Frequency Cable Assembly CG-55G/U connects between AS-1405/PRC-41 and the antenna connector on the front panel of RT-695A/PRC-41. The AS-1405/PRC-41 may be stored in the directional antenna carrying bracket by collapsing the adjustable elements.

(5) ANTENNA MOUNTING BRACKET. (Refer to figure 1-10.) - The antenna mounting bracket permits vertical mounting of Antenna AS-1404/PRC-41 (omnidirectional) in a vehicular installation. It is normally mounted on the rear of Mounting MT-2976/ PRC-41 but may be secured to any flat vertical surface by four screws or bolts. The antenna mounting bracket has a UG-30D/U feedthrough connector. The upper part of this connector fits AS-1404/PRC-41, end the lower part mates with a connector on Radio Frequency Cable Assembly CG-55G/U.

(6) RADIO FREQUENCY CABLE ASSEMBLY CG-55G/U. (Refer to figure 1-11.) - Radio Frequency Cable Assembly CG-55G/U is a 20-foot length of RG-213/U coaxial cable with mating connectors used for connection between the antenna connector on the front panel of RT-695A/PRC-41 and AS-1405/PRC-41 or AS-1404/PRC-41 with adapter UG-29B/U.

(7) POWER ELECTRIC CABLE ASSEMBLY CX-8686/PRC-41. (Refer to figure 1-11.) - Power Electric Cable Assembly CX-8686/PRC-41 is a 10-foot length of a 3-wire electrical cable with mating connectors used for connection of Power Supply PP-3700/ PRC-41 to Mounting MT-2976/PRC-41 or to dc maintenance adapter for RT-695A/PRC-41 when CY-3884/ PRC-41 is removed.

(8) POWER ELECTRIC CABLE ASSEMBLY CX-8687/PRC-41. (Refer to figure 1-11.) - Power, Electric Cable Assembly CX-8687/PRC-41 is a 50-foot length of 3-wire cable with suitable mating connectors used to connect Power Supply PP-3700/PRC-41 to 115-volt, 50- to 400-Hz primary supply.

(9) SPECIAL PURPOSE ELECTRICAL CABLE ASSEMBLY CX-8688/PRC-41. (Refer to figure 1-11.) - Special Purpose Electrical Cable Assembly CX-8688/PRC-41 is a 10-foot length of 7-conductor cable with suitable mating connectors used to connect the H33E/PT connector on one Radio Receiver-Transmitter RT-695A/PRC-41 to the H33E/PT connector on another RT-695A/PRC-41 for automatic relay operation. Refer to paragraph 2-4e of the Installation and Operation Technical Manual for Radio Set AN/PRC-41A. NavShips 0967-872-5010.

(10) DC ADAPTER CABLE. (Refer to figure 1-11.) - The dc adapter cable is a 2-wire cable with a suitable connector on one end and terminal lugs on the other, and is used in a vehicular installation to connect power between the vehicle dc power source and the rear connector of Mounting MT-2976/PRC-41 through Special Purpose Electric Cable Assembly CX-8688/PRC - 41.

(11) MAINTENANCE CABLE KIT. (Refer to figure 1-12 ) - The maintenance cable kit is composed of five multipin cables, one Microdot cable, two Conhex cables, a BNC -to-Conhex connector, a Conhex-to-Conhex connector, and a dc maintenance adapter.

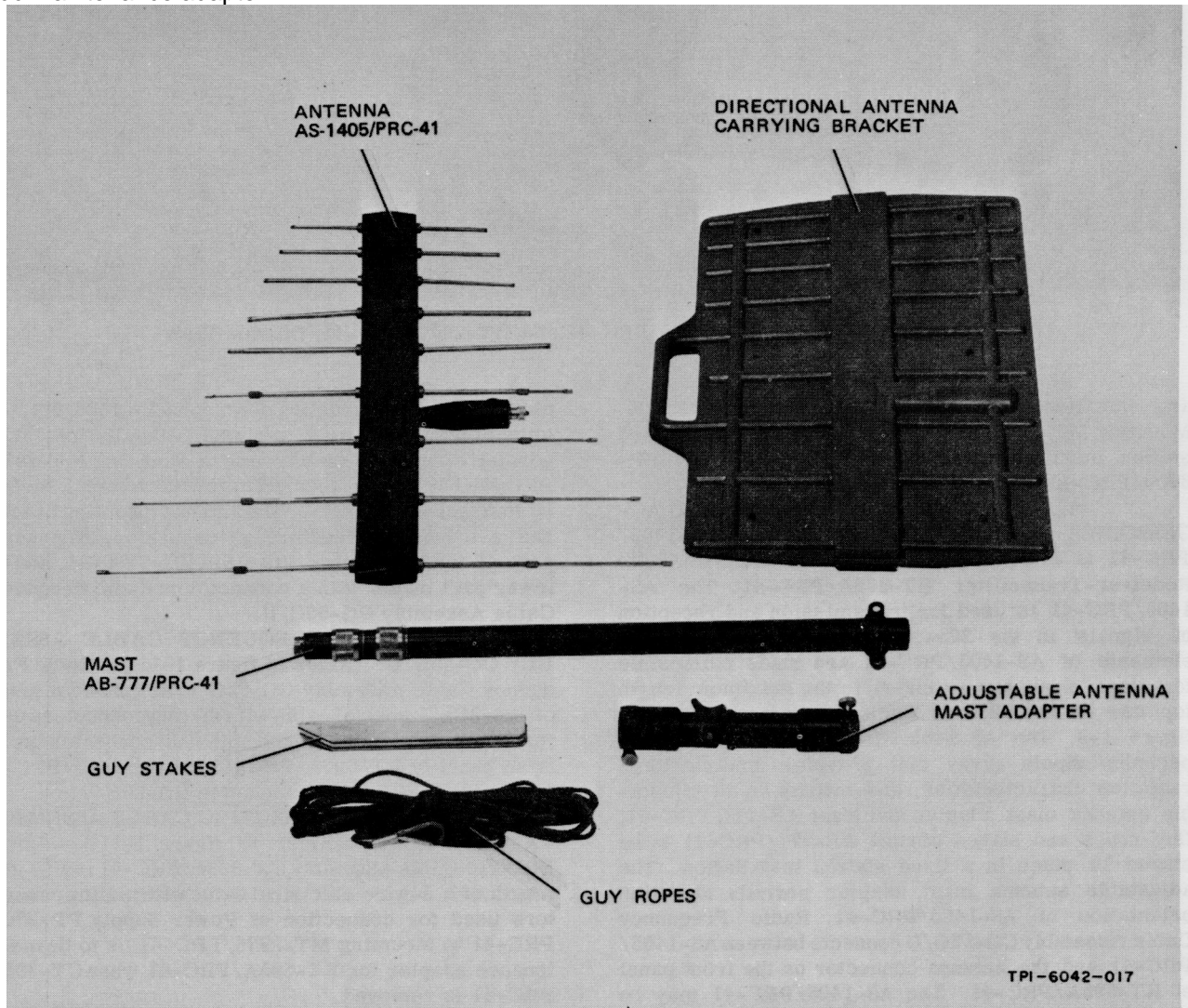

Figure 1-9. Antenna AS-1405/PRC-41, Mast AB-777/PRC-41 and Accessories



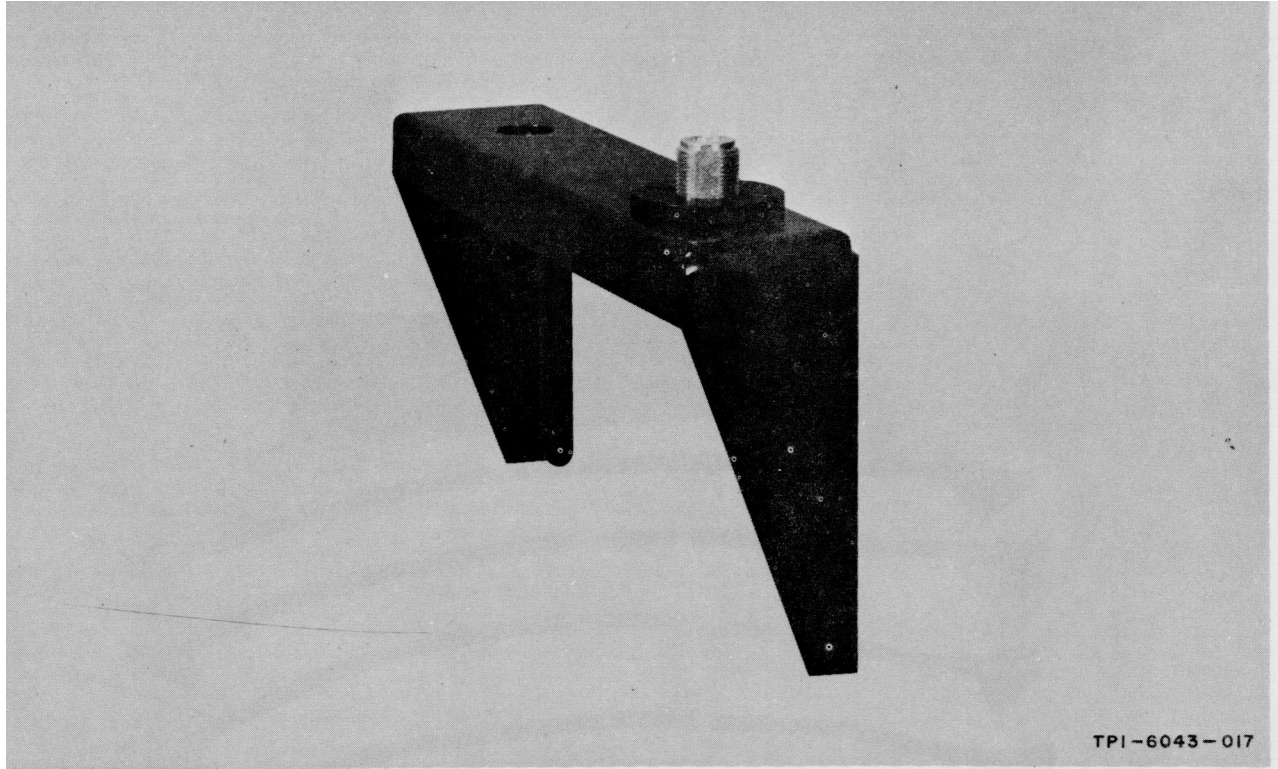

Figure 1-10. Antenna Mounting Bracket

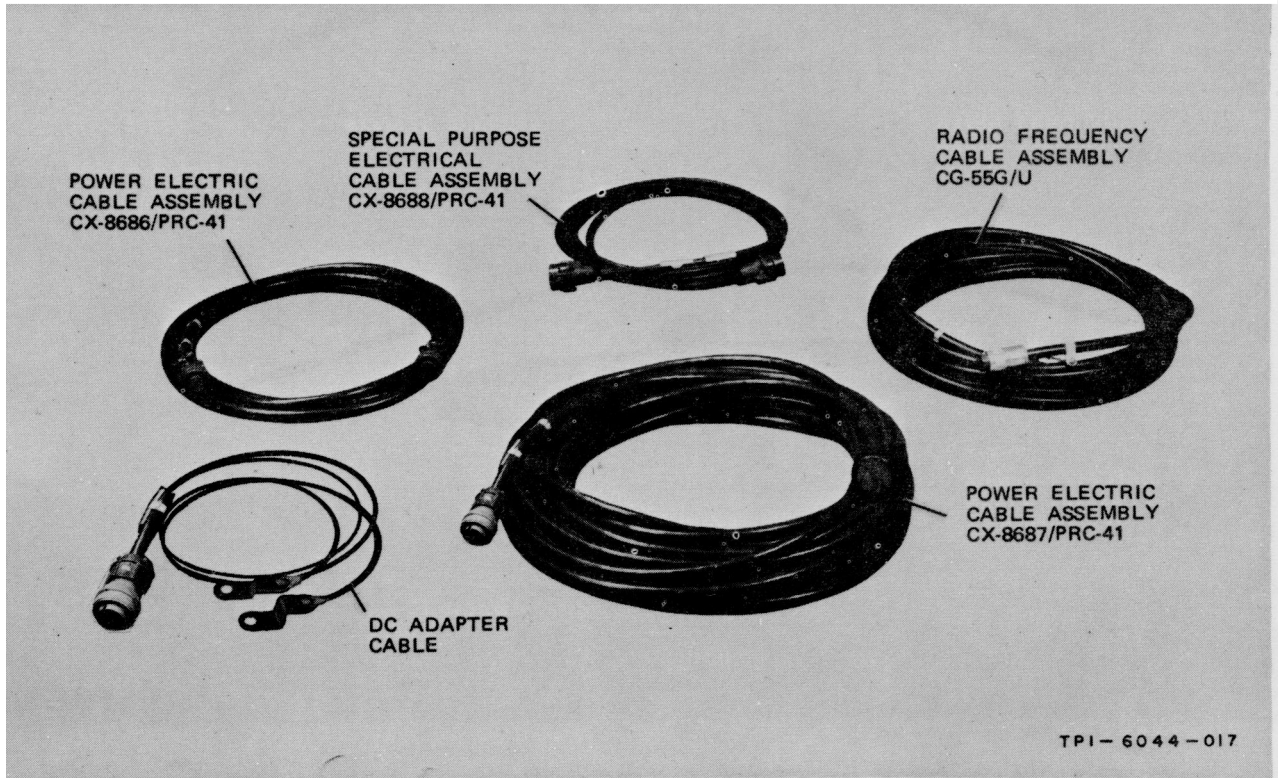

Figure 1-11. Cable Assemblies

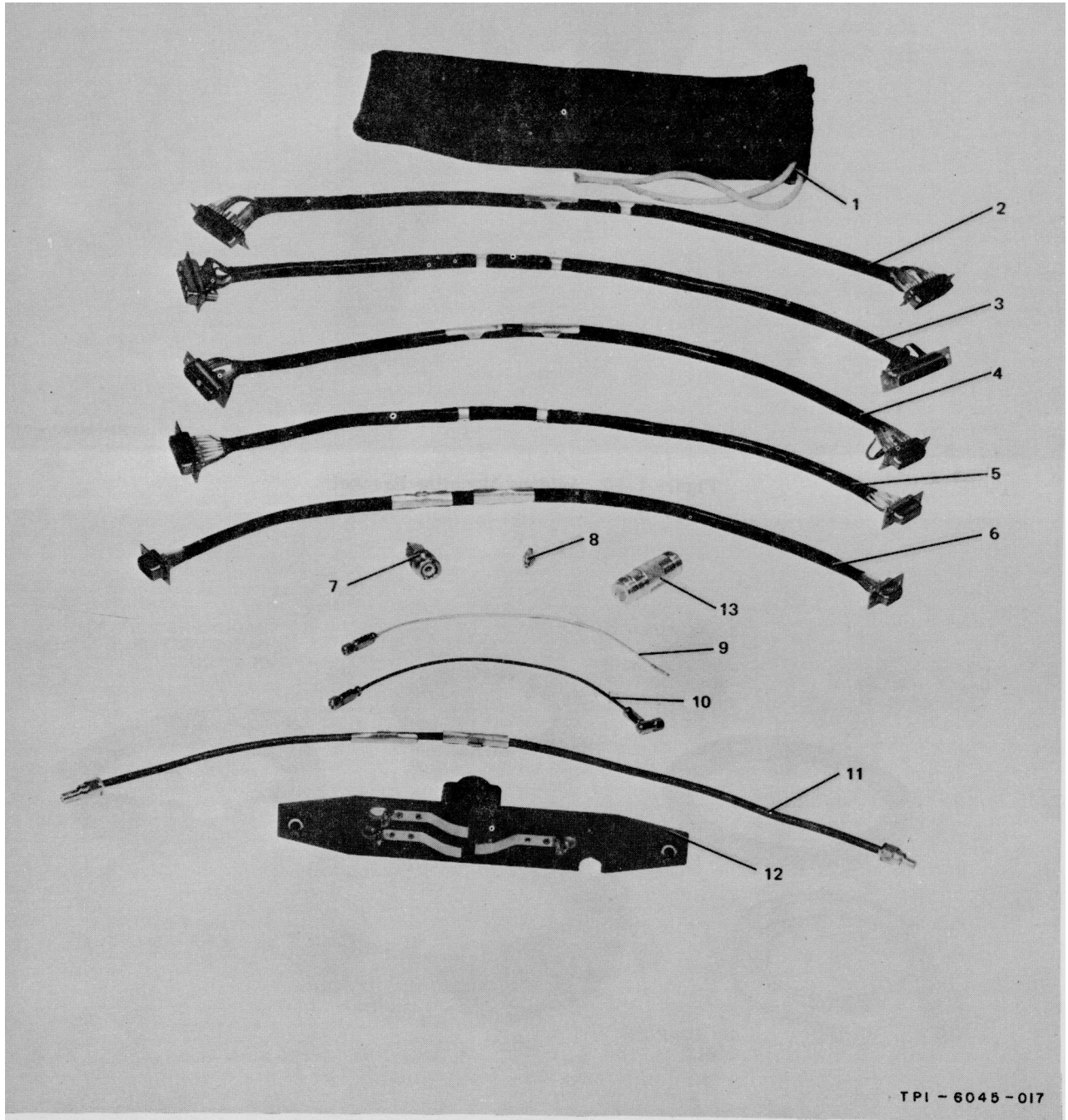

Figure 1-12. Maintenance Cable Kit

The multiwire and Microdot cables are used for operating the modules of RT-695A/PRC-41 extended from the main chassis while performing maintenance procedures. The Conhex cables, BNC-to-Conhex, and Conhex-to-Conhex connectors provide adaptations for connection of test equipment. With Receiver-Transmitter Case CY-3884/PRC-41 removed from RT-695A/PRC-41, the dc maintenance adapter may be secured to the rear of the RT-695A/PRC-41. This permits application of primary power while performing maintenance procedures. The dc maintenance adapter is a 3-wire pressure contact to connector adapter. Refer to table 1-4.

(12) TOOL KIT. (Refer to figure 1-13.) - The tool kit contains the special tools supplied for adjustment and maintenance of RT-695A/PRC-41. Refer to table 1-5.

#### 1-6. REFERENCE DATA.

a. POWER REQUIREMENTS. - Normal power requirements are 26.5 volts dc, 10 percent (equipment will operate with an input voltage as low as 22 volts dc When using ac Power Supply PP-3700/PRC-41, the input voltage is 115 or 230 volts  $\pm 10$  percent, 50 to 400 Hz single phase. AC Power Electric Assembly Cable CX-8687/PRC-41 is normally connected for 115 volts, requiring cable fabrication for operation from a 230-volt source. Refer to paragraph 2-5b(1) of the Installation and Operation Technical Manual for Radio Set AN/PRC-41A, NavShips 0967-872-5010, for 230-volt operation.

#### b. FREQUENCY DATA.

- (1) Range: 225.0 to 399.9 MHz.
- (2) Channels: 1750 spaced at 100-kHz intervals over the range.
- (3) Stability:  $\pm 15$  kHz
- (4) Type of frequency control: Crystal.
- (5) Number of crystals: 39.
- (6) Type of transmission and reception: A3 or A9.

#### c. TRANSMITTER DATA.

- (1) Power output: 3 watts or greater average unmodulated power into a 50-ohm load.
- (2) Modulation: AM.
- (3) Modulation sensitivity: Carbon microphone input of 0.7 volt.
- (4) Modulation capability: 80 percent minimum (adjusted to clip between 70 to 90 percent).
- (5) Transmitter fidelity: +4 dB, 300 Hz to 20 kHz (from 1000-Hz reference).
- (6) Transmitter distortion: Less than 10 percent with modulation 3 dB below clipping level.
- (7) Duty cycle: 1-minute transmit, e-minute receive, extended transmit cycle permissible.

#### d. RECEIVER DATA.

- (1) Sensitivity: A signal having an average level of 3 K V modulated 30 percent at 1000 Hz produces at least 7 mW at a signal-plus-noise to noise ( $s+n$ )/ $n$  ratio of 10 dB or greater.

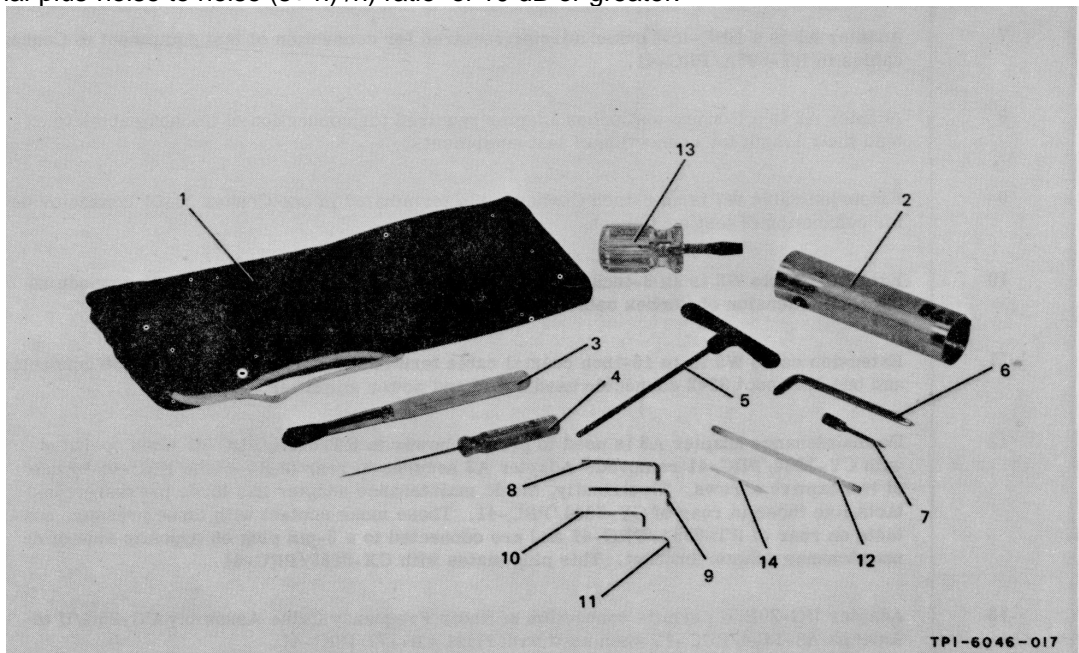

Figure 1-13. Contents of Tool Kit

**TABLE 1-4. CONTENTS OF MAINTENANCE CABLE KIT**

ITEM NUMBER	DESCRIPTION AND PURPOSE
1	Canvas bag, container for cables and adapters
2	Extension cable W2 IS an 18-inch cable terminated m Cannon DBM-F13C3P (C27) and Cannon DBMF-K13C3S(C27)-1, having 10 pins and 3 coaxial connections. Extension cable We IS used with 1st and 2nd lf amplifier module.
3	Extension cable W3 IS an 18-inch cable terminated In Cannon DAM-H11C1P (C27) and Cannon DAMF-KIICIS(C27)-1, having 10 pins and 1 coaxial connection Extension cable W3 Is used with spectrum generator and guard receiver modules
4	Extension cable W1 IS an 18-inch cable terminated m Cannon DBM-21W1P (C27) and Cannon DBM-21W1S, having 15 pins and 1 coaxial connection. Extension cable W1 IS used with rf and power amplifier module.
5	Extension cable W4 IS an 18-inch cable terminated In Cannon DA-15P-C7 and Cannon DAF-15S-C7 connectors, having 15 pins. Extension cable W4 Is used with 3rd lf and squelch module.
6	Extension cable W5 IS an 18-inch cable terminated In Cannon DE-9P and Cannon DEF-9S, having nine pins Extension cable W5 IS used with do power supply, modulator, and audio modules.
7	Adapter At IS a BNC-to-Conhex adapter required for connection of test equipment to Conhex cables In RT-695A/PRC-41.
8	Adapter A2 IS a Conhex-to-Conhex adapter required for connection of Conhex cables to ex tend their length for connection of test equipment.
9	Extension cable W7 IS an 8-inch Conhex cable terminated In one Conhex 33-01 connector used for connection of test equipment
10	Extension cable W6 IS an 8-inch Conhex cable terminated In two Conhex 33-01 connectors used for extension of Conhex cables and connection of test equipment.
11	Extension cable We IS an 18-inch coaxial cable terminated In one Microdot 51-258 connector and one Microdot 3242 connector used for rf and power amplifier module.
12	Dc maintenance adapter As Is used to provide power to RT-695A/PRC-41 when operated with CY-3884/PRC-41 removed. Adapter AS secures to rear of RT-695A/PRC-41 by use of two captive screws Electrically, the do maintenance adapter has three pressure contacts like those In rear of CY-3884/PRC-41. These make contact with three pressure contacts on rear of RT-695A/PRC-41 and are connected to a 3-pin plug on opposite side of dc maintenance adapter bracket. This plug mates with CX-8686/PRC-41.
13	Adapter UG-29B/U permits connection of Radio Frequency Cable Assembly CG-55G/U to Antenna AS-1404/PRC-41 when used with Mast AB-777/PRC-41.

TABLE 1-5. CONTENTS OF TOOL KIT

ITEM NUMBER	NAME	PURPOSE
1	Canvas bag	Container for tools.
2	Spanner wrench	Used for removing antenna connector J28 Handset H-33E/PT, connector J13, and KY-38 connector J14 on front panel of Radio Receiver-Transmitter RT-695A/PRC-41, and antenna connector on antenna mounting bracket
3	Brush	Used to clean connectors
4	Screwdriver	Used for adjustment of trim pots and tuning capacitor of 1st and 2nd if amplifier, 3rd If and squelch, guard receiver, spectrum generator, modulator, and audio modules.
5	T-handle wrench	Used for loosening captive screws on modules of RT-695A/PRC -41
6	Cross-recessed screwdriver	Used for removal and replacement of module side cover screws and for removal of main chassis back plate of R T-695A/PRC -41
7	Alignment tool	Used for adjustment of If coils in guard receiver
8	Multiple spline socket wrench # 8	Used to tighten all coupler clamps on main chassis gear tram.
9	Multiple spline socket wrench #6	Used for setscrews on all knobs on front panel and setscrews in gears of main chassis of RT-695A/PRC-41.
10	Multiple spline socket wrench #4	Used for setscrews in main chassis gear tram, as required
11	Multiple spline socket wrench #2	Used for adjustment of rotor and grounding hub setscrews in rf and power amplifier, and spectrum generator modules.
12	Alignment tool	Used for adjusting trimmer capacitors of rf and power amplifier module.
13	Screwdriver	Used for loosening and tightening captive screws of dust cover of Power Supply PP-3700/PRC-41, Storage Battery BB-451/U, and Receiver-Transmitter Case CY-3884/PRC-41
14	Alignment tool	Used for tracking rf and power amplifier and spectrum generator modules.

- (2) Selectivity: 6 dB, 80 kHz minimum; 60 dB, 150 kHz maximum.
  - (3) Images and spurious responses: 70 dB down (50 dB for signals within 500 kHz of desired channel; 45 dB for subharmonics.)
  - (4) If rejection: 80 dB down.
  - (5) Avc characteristics: Output within +3 dB from 10 to 100,000 uV (from 1000-microvolt reference) .
  - (6) Blocking: No blocking for input signals up to 0.5 volt.
  - (7) Squelch operation: A change in audio output of at least 10 dB is effected by a 1-dB change in input signal.
  - (8) Ultimate (s+n)/n ratio: At least 35 dB (measured at 1000 uV).
  - (9) Audio output: 50 mW into a 300-ohm load with 30-percent modulation, 1000 TV.
  - (10) Audio fidelity: +1, -3 dB from 300 to 3500 Hz (from 1000-Hz reference).
  - (11) Audio distortion: Less than 10 percent at 50-mW output.
- e. MAIN RECEIVER AUXILIARY OUTPUT DATA.
- (1) Sensitivity: Signal with average level of 3 uV, modulated 80 percent at 1000 Hz, produces at least 0.25 volt at a (s+n)/n ratio of 6 dB or greater.
  - (2) Audio distortion: 15 percent maximum at 1000 uV input.
  - (3) Ultimate (s+n)/n ratio: 24 dB minimum (measured at 1000 uV modulated 30 percent).
  - (4) Audio fidelity: +4 dB from 300 Hz to 20 kHz (from 1000-Hz reference).
- f. GUARD RECEIVER DATA.
- (1) Sensitivity: A signal having an average level of 5 uV into the guard receiver modulated 30 percent at 1000 Hz produces at least 7 mW at a (s+n)/n ratio of 10 dB or greater.
  - (2) Selectivity: 6 dB, 50 kHz minimum; 60 dB, 200 kHz maximum.
  - (3) Images and spurious responses: 60 dB down.
  - (4) If rejection: 80 dB down.
  - (5) Avc characteristics: Output within +3dB from 10 to 100,000 uV (from 1000-uV reference).
  - (6) Blocking: No blocking for input signals up to 0.5 volt.
  - (7) Squelch operation: A change in audio output of at least 10 dB is effected by a 1-dB change in input signal.
  - (8) Ultimate (s+n)/n ratio: At least 35 dB (measured at 1000 uV)
  - (9) Audio output: 50 mW into a 300-ohm load with 30-percent modulation. 1000 uV
  - (10) Audio fidelity: +1, -3 dB from 300 to 3500 Hz (from 1000-Hz reference).
  - (11) Audio distortion: Less than 10 percent at 50-mW output (1000-uV input, 1000 Hz 30 percent modulated).
- g. GUARD RECEIVER AUXILIARY OUTPUT DATA. -A signal having a 5 -u V level into guard receiver modulated 30 percent at 1000 Hz produces at least 0.15 volt at a (s+n)/n ratio of 6 dB or greater.

#### 1-7. FACTORY OR FIELD CHANGES.

Effective the date of this technical manual, there have been no factory or field changes to Radio Set AN/PRC-41A or Radio Accessory Kit MK-706/PRC-41. This manual is valid for all units of Radio Set AN/ PRC-41 modified to Radio Set AN/PRC-41A by modification kits supplied under Navships N00024-67-C1566.

#### 1-8. PREPARATION FOR RESHIPMENT.

To prepare Radio Set AN/PRC-41A and Radio Set Accessory Kit MK-706/PRC-41 for reshipment, return all items and accessories to their respective cases. See figures 2-1 and 2-2 of the Installation and Operation Technical Manual for Radio Set AN/ PRC-41A, NavShips 0967-872-5010. Replace Radio Set Case CY-3883/PRC-41 and Electronic Equipment Case CY-3885/PRC-41 in their packing boxes, and carefully nail the crate planking in place. Properly mark the packing boxes for reshipment or storage.

## SECTION 4 TROUBLESHOOTING

### 4-1. LOGICAL TROUBLESHOOTING.

a. HISTORICAL DATA AVAILABILITY. When adequate historical data is not available, troubleshooting procedures should be based on the following six logical steps.

(1) SYMPTOM RECOGNITION. - This is the first step in the troubleshooting procedure and is based on a complete knowledge and understanding of equipment operating characteristics. All equipment troubles are not the direct result of component failure; therefore, trouble in an equipment is not always easy to recognize since all conditions of less than peak performance are not always apparent. This type of equipment trouble is usually discovered while accomplishing preventive maintenance procedures. It is important that the not so apparent troubles, as well as the apparent troubles, be recognized.

(2) SYMPTOM ELABORATION. - After an equipment trouble has not been recognized, all the available aids designed into the equipment should be used to elaborate further on the original trouble symptom. Front panel controls should provide a better identification of the original trouble symptom; also, checking or otherwise manipulating the operating controls may eliminate the trouble.

(3) LISTING PROBABLE FAULTY FUNCTION. - The next step in logical troubleshooting is to formulate a number of logical choices as to the cause and functional section of the trouble. The logical choices are based on knowledge of the equipment operation, a full identification of the trouble symptom, and information contained in this manual. The overall functional description and its associated block diagram should be referred to when selecting possible faulty functional sections.

(4) LOCALIZING THE FAULTY FUNCTION. -(Refer to figure 4-1). For the greatest efficiency in localizing trouble, the functional sections which have been selected by the logical choice method should be tested in an order that will require the least time. This requires a choice to determine which section to test first, and should be based on the validity of the logical choice and the difficulties in making the necessary tests. If the tests do not prove that functional section to be at fault, the next selection should be tested, and so on until the faulty functional section is located. As an aid to this process, the manual contains a functional description and a servicing block diagram of the functional sections. Pertinent indications are included at significant check points on the servicing block diagram to aid in isolating the faulty section; also, test data (such as information on control settings, critical adjustments, and required test equipment) are supplied to augment the functional description and servicing block diagram of the functional sections.

(5) LOCALIZING TROUBLE TO THE CIRCUIT. - After the faulty functional section has been isolated, it may be necessary to make additional choices as to which circuit or group of circuits is at fault. The servicing block diagram of the functional sections and the individual functional circuit groups (where required) provide the signal flow and test location information needed to bracket and then isolate the faulty circuit. Functional descriptions, simplified schematics, and pertinent test data for individual circuits or groups of circuits of the functional section are all placed together in one area of the manual. Information which is too lengthy in nature to be included in this arrangement is readily referenced from the test data portion of the troubleshooting information.

(6) FAILURE ANALYSIS. - After the trouble (faulty component, misalignment, etc) has been located, but prior to performing corrective action, the procedures followed up to this point should be reviewed to determine exactly why the fault affected the equipment in the manner it did. This review is usually necessary to make certain that the fault discovered is actually the cause of the malfunction and not just the result of the malfunction.

b. GENERAL TROUBLE ISOLATION. - Except where noted, the Radio Receiver-Transmitter RT-695A/PRC-41 which is being tested, shall be connected according to the test setup illustrated in figure 5-21. When trouble has been isolated to a particular module of RT-695A/PRC-41, the defective module may be replaced by a like module known to be operative, and the equipment returned to tactical service. Refer to paragraph 5-4b for removal and 5-4g for replacement procedures of the modules of the RT-695A/PRC-41, as required.

(1) USE OF GENERATOR PAD CN-315/ URM-26. Test procedures of this section and section 5 make reference to the use of Signal Generator Pad CN-315/URM-26. When the CN-315 is used with the AN/USM-44A, the attenuator dial on the AN/USM-44A is read in terms of microvolts across 50 ohms and the indication must be

**TM 11-5820-510-35-1/NAVELEX 0967-872-5020**

multiplied by two. (The CN-315/URM-26 is a 6-db pad.) When the CN-315 is not used, the attenuator dial indication (in microvolts) is unchanged.

(2) TRANSISTOR SERVICING. Techniques and precautions of servicing transistorized circuit should be pointed out to the technician. Although transistors are expected to operate indefinitely, they are subject to abuse, and unless special maintenance techniques are used, they will be ruined.

(a) Surface barrier and drift transistors which can operate at high frequencies are

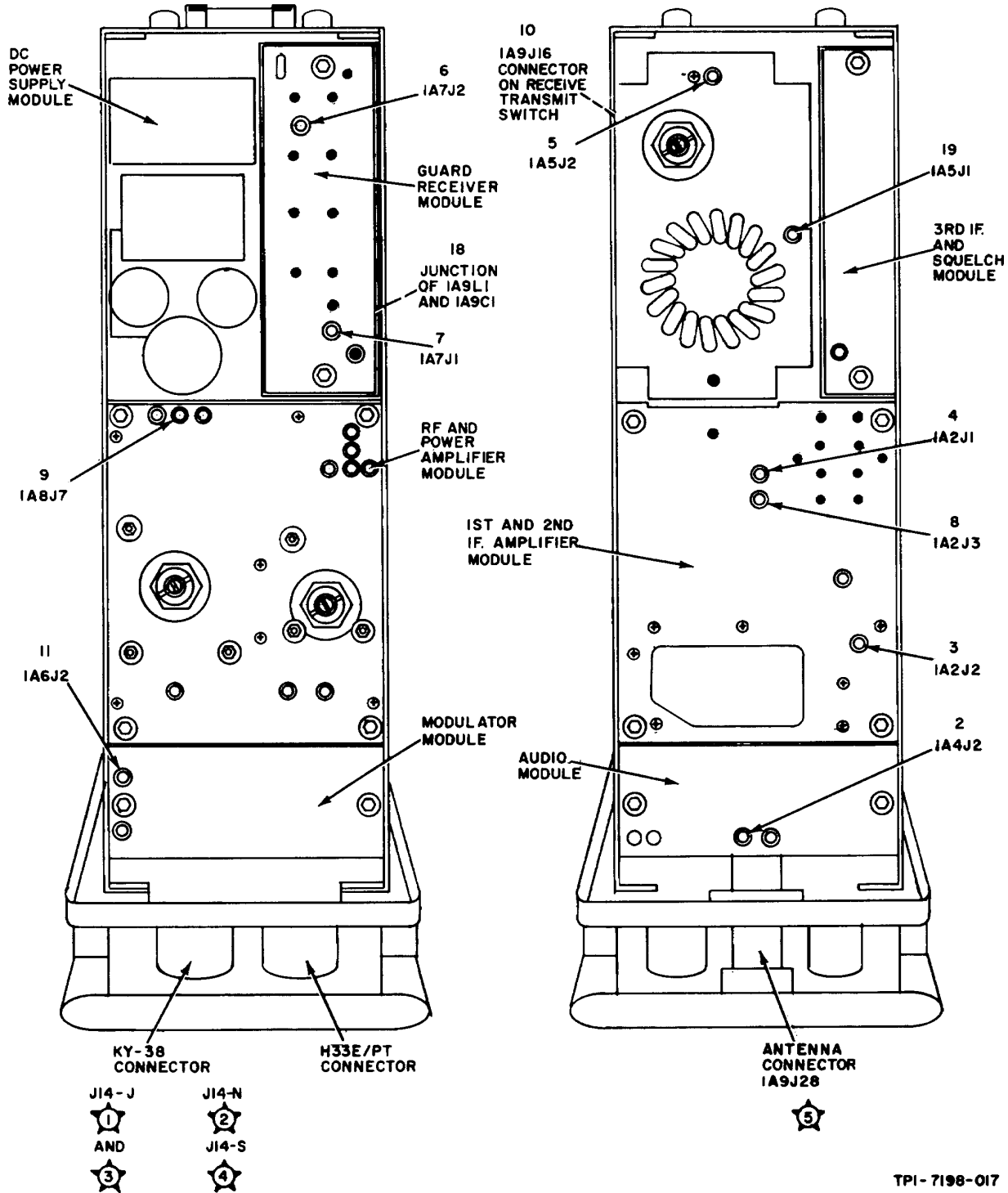

TPI-7198-017

Figure 4-1. Radio Receive Transmitter RT-695A/PRC-41, Module and Test-Point Locations.



becoming widely used and are especially sensitive to certain kinds of overload during routine servicing. Transistors are like semiconductor diodes in this respect, except that the circuits are more complex, and because of the interaction between circuits, even more understanding is required. Parts can be burned out when measuring resistances with a multimeter even when the power supply is turned off. This means that personnel must not indiscriminately measure parts values, as has been a practice with electron tube circuits. An additional complexity results because the circuits normally use bypass and coupling capacitors designed for the lower voltages and may be damaged by the usual multimeter.

(b) Improper servicing techniques can ruin costly transistors. All personnel using or servicing transistorized equipment should know the limitations of the transistor, before applying any test signal (even a multimeter) to a transistor circuit, and should check the maximum allowable current, voltage, and power dissipation ratings of each transistor. Since the resistance of a transistor changes with the magnitude and polarity of applied voltages, it is useful to consider the transistor as a simple switch or matched impedance when computing an ultrasafe maximum signal which may be applied to a particular element. The effect on associated circuits should be considered.

(c) Table 4-1, although necessarily general, provides adequate information, in most cases, for the technician who services transistorized equipment. Figure 4-2 provides an outline and locates the base, collector, and emitter leads of the various transistor types which are used in Radio Receiver-Transmitter RT-695A/PRC-41 and Power Supply PP-3700/PRC -41.

**TABLE 4-1. HOW TO AVOID DAMAGE TO TRANSISTORS WHILE SERVICING CIRCUITS**

SOURCE OF ABUSE	SUGGESTIONS
-----------------	-------------

Basic Failure, Voltage Breakdown, or Punch Through.

Note

Voltage breakdown is especially critical in surface barrier types of transistors.

Cause: Safe voltage is exceeded in the nonconducting direction. Allowable values for surface barrier transistors are on the order of 15 volts from collector to emitter and 0.5 volt from base to emitter. Sometimes 0.1 volt can be excessive.

<p>Short-circuiting series parts, such as the load resistor, with test prods, screwdriver, or soldering iron, permitting the voltage on the transistor to rise.</p> <p>Using multimeter on high-resistance measuring range (22.5 volts of Multimeter AN/PSM-4C, for instance, is too high for surface barrier transistors)</p> <p>Using soldering iron which connects ac from line by leakage or capacitance</p> <p>Connecting leads from ungrounded test set to transistor, causing rf filter to connect voltage to transistor.</p>	<p>Do not short parts with voltages present. Use very small test prods. Insulate prods to the tips. If a screwdriver is used near active transistor circuits, it should be small and well insulated. Turn off power to transistors before using soldering iron or uninsulated tools. Keep transistor away from high-voltage circuits. Avoid use of resistance measuring circuits unless safe. Remove batteries from multimeter or use series and parallel resistors to limit current and voltages to safe values. Use 6-volt iron or isolation transformer. Always turn transistor circuits off and, observing safety precautions, connect a common ground before soldering. Ground all cases together using short ground connections. Use all safety precautions necessary.</p>
--	--

**TABLE 4-1. (Continued)**

SOURCE OF ABUSE	SUGGESTIONS
<p>Using transformerless ac sets or test sets.</p> <p>Using equipment with faulty power supply.</p> <p>Accidentally connecting other voltages to transistor.</p>	<p>Not recommended. However, If necessary to use them, connect an electrostatically shielded isolation transformer (1 1 ratio) In the power line of the transformerless set for safety, and use common ground Check voltages before connecting test leads between equipments to assure safe values.</p> <p>Repair power supply.</p> <p>Check for test lead voltage that might damage transistor, and If evident, eliminate it before connecting. Ground and short probes and test leads to discharge any test set capacitors before connecting, when applicable.</p>
<p>Basic Failure, Burnout, or Runaway.</p> <p>Cause Allowable power dissipation is exceeded In any part of the transistor</p>	
<p>Shorting out, shunting, or grounding the transistor input resistor with power applied, causing Inadequate bias.</p> <p>Connecting the collector voltage without the proper emitter to base bias voltage.</p> <p>Using multimeter (battery) on the low resistance range.</p> <p>Shorting any parts that cause excessive power to be applied to the transistor.</p> <p>Using an ungrounded soldering Iron, thus connecting leakage current Into the transistor circuit.</p> <p>Inadvertently connecting voltages or currents (such as radio Interference filter current, or leakage from the power line, rf pickup, external batteries, power supply voltages, or test oscillator voltages).</p>	<p>Use extreme care to avoid shorts or shunts. Insulate test prods to the tip</p> <p>Do not connect test leads to transistor if ends of leads are free to short circuit. Use only insulated prods, or turn off the power Include dc isolation (suitable capacitor) between signal source and transistor</p> <p>Avoid connecting transistors or plugging them into sockets unless the power supply voltages are off</p> <p>Check on allowable currents and voltages for transistor elements Restrict resistance measuring ranges to safe ones or use limiting resistances (series and parallel as necessary).</p> <p>Do not use a voltmeter of low resistance or other device that will radically affect circuit resistance or voltages, in either the base or collector circuits.</p> <p>Do not solder, connect, or disconnect with voltages on transistor. Ground iron tip (through shank) to transistor circuit ground In a safe manner, use isolation (1 1 ratio) transformer or use 6-volt iron Disconnect heated Iron before soldering if iron is large enough to hold necessary heat.</p> <p>Ground chassis or cases using all necessary safety precautions Reduce stray fields (use insulated shield, if necessary). Before connecting, check test lead voltage compared to that of</p>

**TABLE 4-1. (Continued)**

SOURCE OF ABUSE	SUGGESTIONS
Inducing current by magnet/c field of a soldering gun (such as the transformer type)	transistor circuit with Electronic Multimeter AN/USM-116 to assure low enough voltage Do not connect low Impedance device across equipment voltage or current supplies or loads.  Do not use high current carrying conductor or soldering device near wiring.
Subjecting transistor to power line transients	Use a suitable supply and power source.

**4-2. OVERALL FUNCTIONAL DESCRIPTION.**

a. RADIO SET AN/PRC-41A.-Radio Receiver-Transmitter RT-695A/PRC-41 is composed of eight plug-in modules and a main chassis. See figure 4-1 for relative module location and identification. The RT-695A/PRC-41 is a receiver-transmitter that provides radiotelephone (A3) communication from ground to air and ground to ground. Refer to figure 4-3, a functional block diagram. There are 1750 channels available, spaced 100 kHz apart, in the range of 225.0 to 399.9MHz. The operator can select each

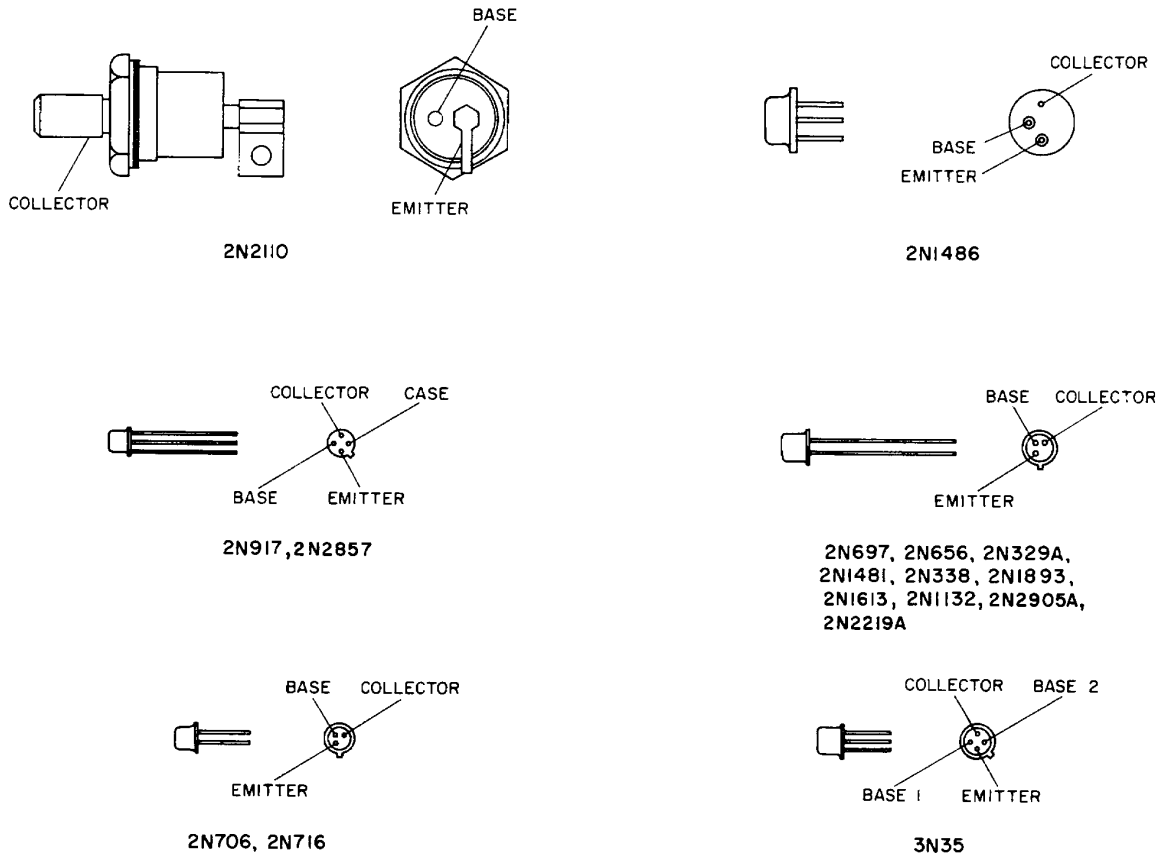

Figure 4-2. Transistor Base Diagrams

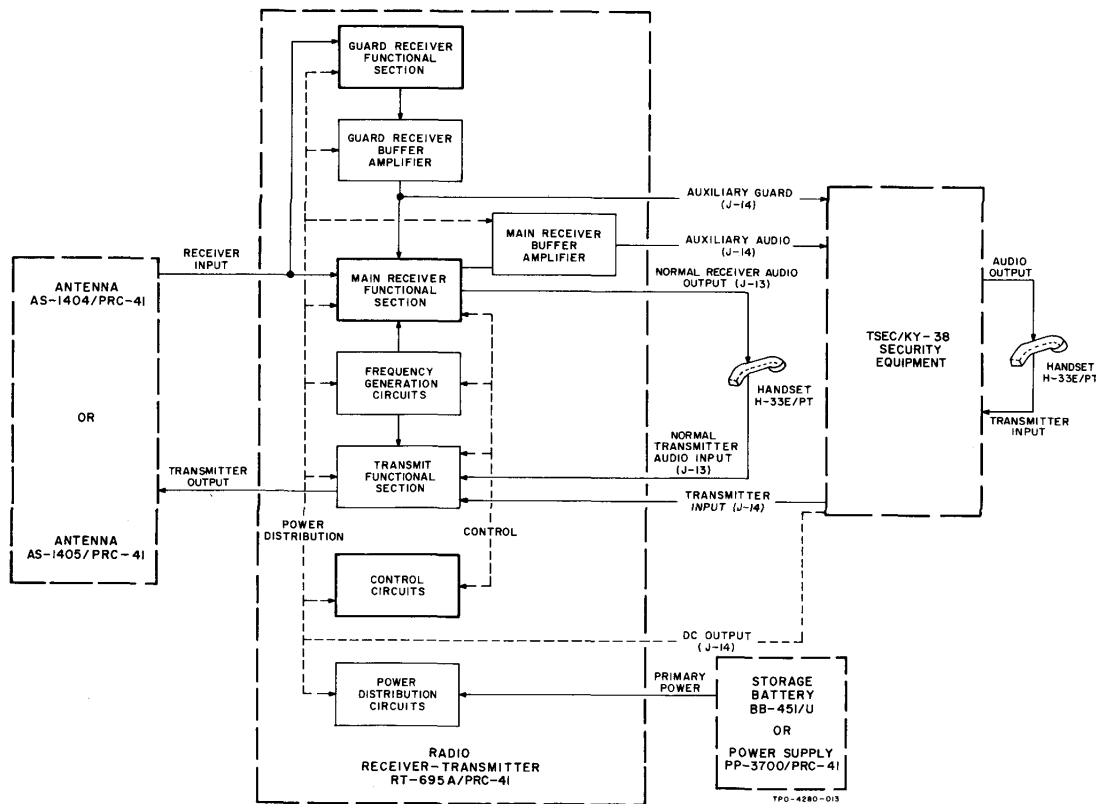

Figure 4-3. Radio Set AN/PRC-41A, Overall Functional Block Diagram

channel by using three selector knobs and a frequency indicator located on the front panel of the RT-695A/ PRC-41. A second fixed-tuned receiver permits monitoring of a predetermined frequency, known as the guard channel, in the 238.0- to 248.0-MHz range (usually tune to 243.0 MHz). Primary power for operating the RT-695A/PRC-41 can be provided by Storage Battery BB-451/U, Power Supply PP-3700/ PRC-41, or by a vehicle or aircraft power source. PP-3700/PRC-41 is used in an aircraft installation if ac power is available. The choice of primary power source is dependent on the operational requirements. Reception and transmission are made and controlled by the press-to-talk switch of Handset H-33E/PT. When the AN/PRC-41A and the TSEC/ KY-38 are connected as a system, the TSEC/KY-38 is connected to the connector provided on the front panel of RT-695A/PRC-41 using Special Purpose Electrical Cable Assembly CX-10831/PRC-41A, and Handset H-33E/PT is connected to the appropriate audio jack on TSEC/KY-38. Reception and transmission is controlled by the handset. When TSEC/ KY-38 interconnect cable is connected to 1A9J14 on the RT-695A/PRC-41, transmission from 1A9J13 is inhibited but reception is possible. The RT-695A/ PRC-41 contains triple-conversion superheterodyne circuits; its main receiver and transmitter functional sections are illustrated in figures 4-4 and 4-5.

(1) Since the units and accessories of AN/ PRC-41A are not electronic in nature, with the exception of Radio Receiver-Transmitter RT-695A/ PRC -41 and Power Supply PP-3700/PRC-41, the description and test information of this section is limited to RT-695A/PRC-41 and PP-3700/PRC-41. It may be necessary to check an antenna or cable assembly for continuity; however, damage to masts, mountings, harness, cases, etc. is obvious from visual inspection. No test information for these items is contained in this section. The RT-695A/ PRC-41 functions in three ways: it provides transmission and reception on 1750 channels in the 225.0-to 399.9-MHz range, and reception on a single frequency, 243.0 MHz, known as the guard channel. The functional sections are therefore identified as the main receiver, guard receiver, and transmitter. Refer to figure 4-3. Primary power, power distribution,

frequency generation, control, and antenna circuits are considered subordinate and common to both the main receiver and transmitter functional sections. The guard receiver functional section contains its own frequency generation circuits. Power distribution circuits are common to all functional sections. RT-695A/PRC-41 may be used with either Antenna AS-1404/PRC-41 or Antenna AS-1405/PRC-41. The receiver output is applied to Handset H33E/PT.

(2) Paragraphs 4-3 through 4-5 provide descriptions and test data for the functional sections. Alignment and adjustment information references the procedures of section 5. Paragraph 4-6 provides descriptions and test data pertinent to the subordinate circuits. Each of the functional sections are broken down into circuits or groups of circuits and into modules. A module is defined as a plug-in subassembly. The lowest level in this breakdown process is the simplest functional block (for example, an audio amplifier stage). Only the circuits which are uncommon (those not covered in the Handbook of Electronic Circuits, NavShips 900,000.102) will be discussed. In all other cases, reference is made to RT-695A/PRC-41 schematic diagrams of section 5 and the servicing block diagram of this section.

b. TEST POINTS. -Significant test points are identified on the functional section servicing block diagram, figure 4-19, and illustrated in figure 4-1 by use of star and circle test symbols. The star test-point symbol identifies and locates test points which are used to isolate trouble to a functional section. Circle test-point symbols identify and locate test points which are used to isolate trouble to a circuit within the functional section. Unless otherwise noted, all test-point voltage measurements are with respect to ground. Refer to table 4-2 and figure 4-1.

**TABLE 4-2. TEST POINTS**

TEST POINT	LOCATION	FIGURE REF	ISOLATE TROUBLE TO	INDICATION
①	1A9J14-J KY-38 connector on front panel of RT-695A/ PRC-41	4-1	Main receiver functional section	Audio output shall be 50 section milliwatts minimum when measured according to procedures of paragraph 4-3b.
②	1A9J14-N KY-38 connector on front panel of RT-695A/ PRC-41	4-1, 4-19	Main receiver functional section	Output voltage shall be 0.25 volt minimum a- cross 25-kz load.
③	1A9J14-J KY-38 connector on front panel of RT-695A/PRC-41	4-1	Guard receiver functional section	Audio output shall be 50 milliwatts minimum when measured according to procedures of paragraph 4-3b.
④	1A9J14-S KY-38 connector on front panel of RT-695A/ PRC-41	4-1	Guard receiver functional section	Output voltage shall be 0 15 volt minimum across 600-ohm load
⑤	Antenna connector 1A9J28 on front panel of RT-695A/ PRC-41	4-1	Transmitter functional section	Transmitter power output shall be at least 3 watts average across 225- to 399 9-MHz range
	Handset H-33E/ PT connected to H33E/PT connector on front panel of RT-695A PRC-41	4-19	Circuits of audio module	Signal should be heard at a reasonable level in H-33E/PT

**TABLE 4-2. (Continued)**

TEST POINT	LOCATION	FIGURE REF	ISOLATE TROUBLE TO	INDICATION
②	1A4J2	4-1	Circuits of audio module	Normal audio signal should be observed on Oscilloscope AN/ USM-105A
③	1A2J2	4-1	Low-frequency oscillator 1A2Q7 of 1st and 2 <sup>nd</sup> if amplifier module.	Measure -2.5 to -3.5 volts dc
④	1A2J1	4-1	High frequency oscillator 1A2Q5 of 1st and 2nd if amplifier module	Measure -0.8 to -1.5 volts dc
⑤	1A5J2	4-1	Circuit of spectrum generator module	Measure -1.5 to -5 volts dc.
⑥	1A7J2	4-1	Transistor stages 1A7Q5 through 1A7Q10 of guard receiver module	Should observe a normal avc rise with an increasing signal input at 20.55 MHz.
⑦	1A7J1	4-1	Oscillator 1A7Q4 of guard receiver module.	Measure -1 to -2 volts dc.
⑧	1A2J3	4-1	Transistor stages 1A2Q6, 1A2Q4. 1A2Q1 and 1A2Q2 of 1st and 2nd if amplifier module.	Measure 1.7 volts dc in transmit mode
⑨	1A8J7	4-1	Rf amplifiers 1A8V1 through 1A8V4 of rf and power amplifier module	Measure +1.8 volts dc
⑩	1A9J16	4-1	Transmit-receive switch 1A9S1 of RT-695A/ PRC-41 main chassis	Set OFF-T/R-T/R/G 1A9J21 DIAL LIGHT switch to OFF with H-33E/PT keyed. Measure zero resistance between 1A9J16 and 1A9J21
⑪	1A6J2	4-1	Circuits of modulator module	Measure 10 volts ac in transmit mode with modulation signal applied.
⑫	Plugs P1 and P3 Power Supply PP-3700/PRC-41	4-8	Circuits of PP-3700/-41 PRC-41	Measure 26.5 volts dc.
⑬	Junction of diodes CR2 and CR4 of PP-3700/PRC-41	4-8	Transformer T1 and diodes CR1 through CR4 of PP-3700/PRC-41	Measure 41 volts dc.

**TABLE 4-2. (Continued)**

TEST POINT	LOCATION	FIGURE REF	ISOLATE TROUBLE TO	INDICATION
14	Terminals 5 and 6 of transformer T1 of PP-3700/PRC-41	4-8	Transformer T1 of PP-3700/PRC-41	Measure 45 volts ac.
15	Red lead on inductor L1	4-8	Inductor L1, relay K1, diodes CR1 through CR4, and transformer T1 of PP-3700/PRC-41	Measure 41 volts dc.
16	Emitter of transistor Q2	4-8	Inductor L1, capacitor C1, and resistor R1 of PP-3700/PRC-41	Measure 37 volts dc.
17	Collector of transistor Q2	4-8	Transistors Q1 through Q4 of PP-3700/PRC-41	Measure 27 volts dc.
18	Junction of 1A9L1 and 1A9C1 on RT695A/PRC-41 main chassis	4-1	Power distribution circuits of RT-695A/PRC-41	Measure 26.5 volts dc.
19	1A5J1	4-1	Spectrum oscillator 1A5V1 of spectrum generator module	Measure -5 to -20 volts dc.
20	1A3J1	4-19	Squelch control circuits and if amplifier stages	Measure approximately +4 volts, no signal input, squelch relay should energize with squelch control on front panel full ccw. Observe normal avc rise with increasing signal input.
21	1A9J25	4-19	Filament circuits	Measure 6.3 volts dc.
22	1A9J27	4-19	Diode mixer	Measure +0.5 to +2.0 volts dc.

c. OVERALL TROUBLE ISOLATION. - If an equipment is known to be inoperative or if the preventive maintenance tests have indicated that it has less than adequate performance, perform the steps of procedure of table 4-3 to isolate the trouble to a functional subordinate section. Before beginning the trouble isolation procedures of table 4-3, inspect the units of AN/PRC-41A for loose cables, charred or discolored insulation, broken wire, improper control settings, or other evidence of equipment malfunction. Check all fuses to be certain that they have not blown, and make certain primary power is available to the equipment. Attempt operation on several channels. Check to see that the panel lights are lighted in the DIAL LIGHT position of the OFF -T/R -T/R/G-DIAL LIGHT switch. If Mounting MT-2976/PRC-41 is suspected to be at fault, use figures 5-64 and 5-99 as aids to troubleshooting.

(1) TEST SETUP. - Perform the test procedures of steps 1 through 4 of table 4-3 with Radio Receiver-Transmitter RT-695A/PRC-41 connected to a Power Supply PP -3700/PRC -41, known to be operative, with Receiver-Transmitter Case CY-3884/ PRC-41 in place on the RT-695A/PRC-41. If these steps do not reveal the source of difficulty, remove CY-3884/PRC-41, and check the frequency generation circuits according to step 5 of table 4-3.

(2) TEST EQUIPMENT REQUIRED.

- (a) Signal Generator AN/USM-44A.
- (b) RF Wattmeter AN/URM-43C.
- (c) Electronic Multimeter TS-505/U.
- (d) Signal Generator Pad CN-315/

URM -26.

- (e) Fuse MX-1730/U.

**ORIGINAL 4-9**

**TABLE 4-3. OVERALL TROUBLE ISOLATION**

STEP	PRELIMINARY ACTION	NORMAL INDICATION	IF INDICATION IS ABNORMAL
1	Connect Handset H-33E/PT to H33E/PT connector on front panel of RT-695A/ PRC-41. Set OFF-T/R-T/R/G-DIAL LIGHT switch to DIAL LIGHT.	Dial lights light. Proceed to step 2.	Refer to paragraph 4-6d, and check power distribution circuits.
2	Connect Signal Generator AN/USM-44A through Signal Generator Pad CN-315/ URM-26, and Fuse MX-1730/U to antenna connector 1A9J28 set for 304.7 MHz modulated 30% with 1000 Hz at 1000 microvolts. Set RT-695A/ PRC-41 to 304.7 MHz, and set OFF T/R-T/R/G-DIAL LIGHT switch to T/R. Rotate VOL control fully clockwise and SQUELCH control full counterclockwise	A 1000-Hz tone should be heard in H-33E/PT. Proceed to step 3.	Proceed to step 5. If performance of step 5 provides a normal indication, refer to paragraph 4-3, and check main receiver functional section. If step 5 is abnormal, refer to paragraph 4-6e, and check frequency generator circuits.
3	Set AN/USM-44A to 243.0 MHz modulated 30% with 1000 Hz at 1000 microvolts. Leave RT-695A/ PRC-41 set to 304.7 MHz. Rotate SQUELCH control fully clockwise Set OFF-T/R-T/R/G-DIAL LIGHT switch to T/R/G	A 1000-Hz tone should be heard in H-33E/PT. Proceed to step 4.	Refer to paragraph 4-4, and check the guard receiver functional section
4	Remove AN/USM-44A, CN-315/ URM-26, and MX-1730/U from 1A8J28. Connect RF Wattmeter AN/URM-43C to antenna connector 1A9J28. Set OFF-T/R-T/R/G- Press press-to-talk switch on H-33E/PT, and measure transmitter power output at several frequencies across range.	Measure 3 watts average across frequency range	Proceed to step 5. If performance of step 5 provides a normal indication, refer to paragraph 4-5, and check transmitter functional section. If step 5 is abnormal, refer to paragraph 4-6e, and check frequency generator circuits.
5	Remove Receiver-Transmitter Case CY-3884/PRC-41 from RT-695A/ PRC-41. Connect RT-695A/ PRC-41 into test setup shown in figure 5-21. Set OFF-T/R-T/ R/G-DIAL LIGHT switch to T/R Measure voltage at test Jacks 1A2J1 and 1A2J2 on 1st and 2nd if amplifier module and at test jack 1A5J2 on spectrum generator module.	Measure -2.5 volts dc. At 1A2J2. Measure -0.7 volt dc. at 1A2J1. Measure 1.5 volts dc. at 1A5J2	Refer to paragraph 4-6e, and check frequency generator circuits.



### 4-3. OVERALL MAIN RECEIVER FUNCTIONAL SECTION.

a. DESCRIPTION. (Refer to figure 4-4.) - The main receiver functional section is composed of the circuits of the rf amplifier-receiver and transmitter module (referred to as the rf and power amplifier module), 1st and 2nd if amplifier module, 3rd if amplifier and squelch module, audio module, and main receiver buffer amplifier along with the switching and interconnecting wiring of the main chassis of the RT-695A/PRC-41. Incoming signals in the 225.0- to 399.9-MHz frequency range are amplified in the rf amplifier stages of rf and power amplifier module 1A8. The frequency scheme of this equipment actually covers an input frequency of 220.0 to 399.9 MHz; however, 225.0 MHz is the lowest frequency used. The received signals in this range are mixed with a 200- to 370-MHz first injection signal in the diode mixer. The resulting 20- to 29.9-MHz first if signal is supplied to 1st and 2nd if amplifier module 1A2, is amplified and mixed with 17.1- to 26.1-MHz second injection signal to produce the 2.9- to 3.8-MHz second if signal. The second if signal is mixed with a 2.9- to 3.8-MHz third if injection signal to produce the 500-kHz third if signal. In receiver operation, crystals are chosen so the third injection signal is either 500 kHz above or 500 kHz below the second if signal frequency. The resulting 500-kHz third if signal is applied to 3rd if and squelch module 1A3 where it is filtered, amplified, demodulated, and noise-limited. Normal audio from 3rd if and squelch module 1A3 is fed through volume control 1A9R4 to audio amplifiers of audio module 1A4 and to the H-33E/PT handset. An output of the audio detector of 3rd if and squelch module 1A3 is fed through the main receiver buffer amplifier to the auxiliary audio output on J14-N. The avc defector end amplifier stages provide avc outputs for two if amplifier stages and the squelch circuits of 3rd if and squelch module 1A3. Avc is also fed to an if amplifier stage in 1st and 2nd if amplifier module 1A2 and to four rf amplifier stages in rf and power amplifier module 1A8.

b. TEST DATA. - In order to determine whether or not the main receiver functional section is faulty, perform the test procedure in step (3) of this paragraph. If the results of the performance test prove the main receiver functional section to be operative, proceed to the next functional section performance test to locate the faulty functional section or sections. Steps (1) through (3) of this paragraph provide the necessary test data to aid in pinpointing or eliminating the functional section under consideration. Refer to the main receiver functional section of the servicing block diagram (figure 4-19) for location of test points, signal flow, and auxiliary circuits such as power distribution, control, and frequency generation. To determine whether or not the main receiver functional section is operative, connect RT-695A/ PRC-41 into the test setup described in step (2) of this paragraph and subject the equipment to the main receiver functional section performance test.

(1) TEST EQUIPMENT REQUIRED.

(a) Signal Generator AN/USM-44A.

(b) Signal Generator Pad CN-315/

URM-26.

(c) Fuse MX-1730/U.

(d) Output Power Meter ME-2/U.

(2) TEST SETUP. - Set Radio Receiver-Transmitter RT-695A/PRC-41 on the test bench, and connect Power Supply PP-3700/PRC-41 to provide the required primary power. Connect Signal Generator AN/USM-44A in series with Signal Generator Pad CN-315/URM-26, Fuse MX-1730/U, and a length of RG-213/U coaxial cable to antenna connector 1A9J28 on the RT-695A/PRC-41. Connect junction box (figure 5-1 and 5-2) to the H33E/ PT connector on the front panel of RT-695A/PRC-41. Connect Output Power Meter ME-2/U to NORMAL AUDIO OUTPUT connector on the junction box. Rotate the VOL control on RT-695A/PRC-41 to maximum clockwise position and the SQUELCH control to maximum counterclockwise position.

(3) FUNCTIONAL SECTION PERFORMANCE TEST.

#### CAUTION

Do not key RT-695A/PRC-41 with AN/USM44A connected to antenna connector 1A9J28. MX-1730/U provides protection for the signal generator attenuator in the event the RT-695A/ PRC-41 is accidentally keyed.

(a) Set AN/USM-44A to 225.0 MHz modulated 30 percent with 1000 Hz.

(b) Set OFF-T/R-T/R/G-DIAL LIGHT switch to T/R. Turn on AN/USM-44A, and allow equipment time to warm up. Carefully adjust AN/USM44A signal output around the 225.0-MHz point to obtain maximum indication on ME-2/U.

(c) Audio power output should be 50 milliwatts minimum. Repeat test on 304.7 and 399.9 MHz. If correct results are not obtained, main receiver functional section is defective.

c. MAIN RECEIVER CIRCUIT DESCRIPTION. - As a further aid in explanation of the main receiver functional section, each circuit making up the functional section is discussed in order of signal flow. Only the circuits that are uncommon (those not covered in the Handbook of Electronic Circuits, NavShips 900, 000.102) will be discussed. See schematic diagrams of section 5 and functional section or servicing block diagrams of this section. Test data is provided to aid in isolation of trouble to a circuit or group of circuits and consequently to a module. Refer to applicable tuning and adjustment procedures of paragraph 5-3. Perform these procedures only when absolutely necessary or following repair as required.

(1) FUNCTIONAL DESCRIPTION. - The main receiver functional section is composed of the circuits of rf and power amplifier, 1st and 2nd if

amplifier, 3rd if and squelch, and audio modules along with switching and interwiring of the main chassis. Discussion of the circuits of main receiver functional section is presented by module in the order of signal flow. See main receiver functional section block diagram, figure 4-4, as an aid in understanding the theory of operation of the main receiver functional section. A signal in the 225.0- to 399.9-MHz range appearing on either Antenna AS-1404/PRC-41 or Antenna AS-1405/PRC-41 is fed through antenna connector 1A9J28 to contact 2 of receiver-transmit switch 1A9S1A and fed to the input of the rf and power amplifier module.

(a) RF AND POWER AMPLIFIER MODULE 1A8. - With exception of the avc amplifier, the same stages of rf and power amplifier module are used in both receive and transmit operations. In receive operation, signals in the 225.0- to 399.9 MHz range are fed through switch contacts of receive transmit switch 1A9S1A to rf and power amplifier module. Four stages of rf amplification, a power amplifier, and an avc amplifier of the rf and power amplifier module are used in receive operation. See figure 5-92.

1. RF AMPLIFIERS V1 THROUGH V4. - Within the rf and power amplifier module, the signal is applied to the cathode of grounded grid rf amplifier V1. The output of first rf amplifier V1 is coupled through grounded grid amplifiers V2 and V3 to rf driver V4. The output from rf driver V4 is capacitively coupled to the cathode of power amplifier V5.

2. POWER AMPLIFIER V5. - Power amplifier stage V5 is a triode tube. In receive operation, the stage acts as a class A amplifier. The output is taken from the plate of power amplifier V5 and fed through contacts of switch 1A9S1 B to diode mixer 1A9CR1. Tuned circuits Z1 through Z5 of the rf and power amplifier module are adjusted to the desired signal in the range of 225.0 to 399.9 MHz. These tuned circuits are mechanically ganged to the frequency selector knobs on the front panel of RT-695A/PRC -41.

3. AVC AMPLIFIER Q1. - Avc voltage from 3rd if and squelch module is applied to the base of avc transistor amplifier Q1. An increase to input signal results in a decrease of the base current and thus increases the collector voltage of Q1. The amplifier avc voltage is applied to the cathode circuits of rf amplifiers V1, V2, V3, and V4. In transmit operation, there is no output from avc amplifier Q1 because the collector of Q1 is grounded by relay 1A9K1.

4. OUTPUT CONTROL RELAY K1. During receive operation, the plate voltage applied to tubes V4 and V5 is lowered by means of dropping resistors R25 and R26. This reduces the amplifier gain to prevent overloading first mixer diode 1A9CR1 when high-level, off-channel signals are applied to the receiver. During transmit, the power amplifier output is applied to the antenna instead of 1A9CR1. Relay K1 is energized, applying full plate voltage to V4 and V5 through relay contacts which provide maximum amplifier gain.

(b) 1ST AND 2ND IF AMPLIFIER MODULE 1A2. - Some stages of the 1st and 2nd if amplifier module are used in both receive and transmit operation. Two if amplifier stages, second and third receiver mixer stages, and high- and low-frequency oscillator stages of the 1st and 2nd if amplifier module are used in receive operation (figure 5-86).

1. IF AMPLIFIERS Q1 AND Q2. The 200- to 370-MHz output from the spectrum generator module is mixed with received signal in the 225- to 399.9-MHz range in diode mixer 1A9CR1. Refer to paragraph 4-6e for a discussion of the frequency generation circuits. The difference frequency is selected to produce the 20- to 29.9-MHz intermediate frequency. With receive-transmit relay 1A2K1 in receive position, the 20- to 29.9-MHz if signal (first intermediate frequency) from diode mixer 1A9CR1 is fed to two 20- to 29.9-MHz if amplifiers. These amplifiers consist of three sets of capacitive coupled parallel-tuned circuits and transistors 1A2Q1 and 1A2Q2. The 20- to 29.9-MHz signal is first applied to a set of parallel-tuned circuits and is then applied through coupling capacitor C4 to base number 1 of tetrode if amplifier transistor Q1. The output from the collector of Q1 is applied to a set of parallel-tuned circuits, through coupling capacitor C56, to the base of if amplifier transistor Q2. The output of Q2 is applied to a set of parallel-tuned circuits and coupled through capacitor C18 to second receiver mixer Q3, or, in transmit operation, through capacitor C21 to the contacts of receive-transmit switch 1A9S1B. The gain of first if amplifier Q1 is controlled by a positive increasing avc voltage applied to the base number 2 of Q1. Selectivity is determined by the three sets of parallel-tuned circuits: one at the input of Q1, one at the output of Q1 and the input of Q2, and one at the output of Q2. The inductances of these parallel-tuned circuits are mechanically ganged and are linearly positioned in 0.1-MHz steps at 3.0 degrees per increment.

2. SECOND RECEIVER MIXER Q3. -During receive operation, high frequency oscillator Q5 provides a 17.1- to 26.1-MHz output to the emitter of second receiver mixer Q3 through resistor R28 and contacts of relay K2. The first intermediate frequency (20 to 29.9 MHz) is applied to base number 1 of tetrode transistor Q3. The difference frequency (2.9 to 3.8 MHz) of the first intermediate frequency and high-frequency oscillator Q5 is selected by tunable bandpass filters, consisting of inductors L19 through L24 and capacitors C24 through C27, C52, and C53. The difference frequency (2.9 to 3.8 MHz) is the second intermediate frequency in receive operation. Inductors L19, L21, and L23 are ganged and are linearly positioned in 0.1-MHz increments at 30 degrees per step. Inductors L20, L22, and L24 are inductive trimmers.

3. THIRD RECEIVER MIXER AND TRANSMITTER BUFFER Q6.- Third receiver mixer

Figure 4-4. Radio Receiver-Transmitter RT-695/PRC-41, Receiver Functional Section Block Diagram

AN/PRC-41A  
TROUBLESHOOTING

NAVSHIPS 0967-872-5020  
TM-03816B-35/2  
TM11-5820-510-35-1

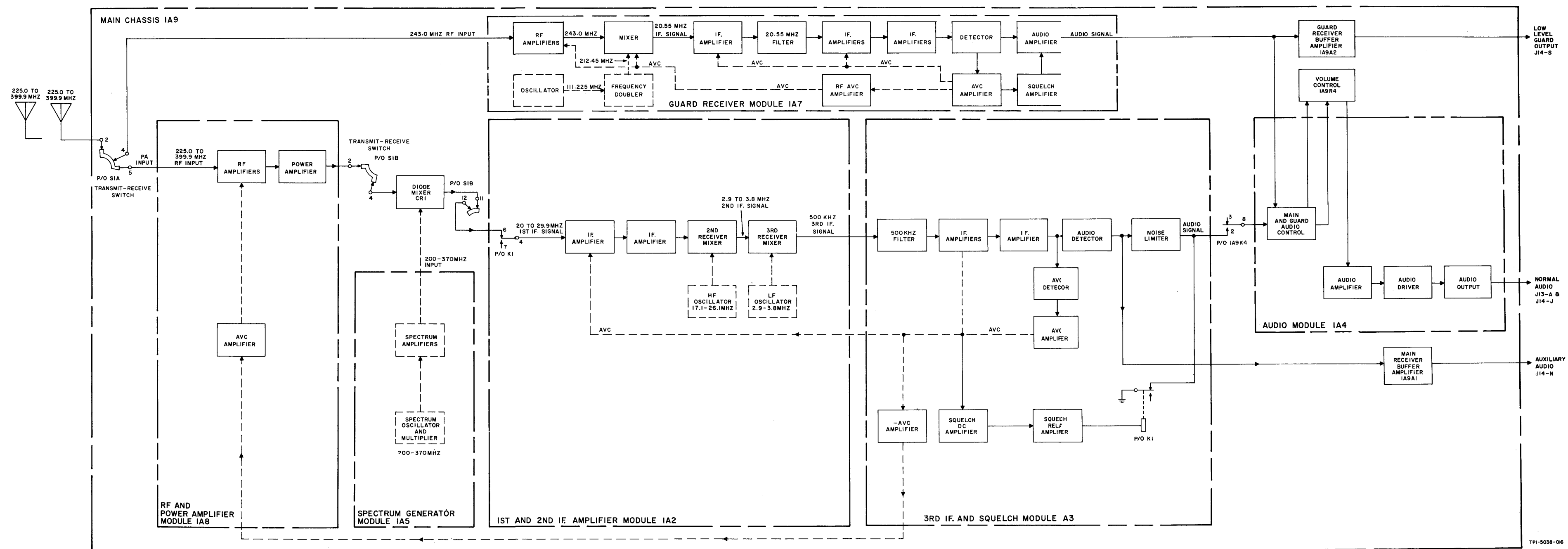

TPI-5038-06

transistor Q6 is similar in operation to Q3 in receive operation. The 2.9- to 3.8-MHz second intermediate frequency is coupled to the emitter of third receiver mixer Q6 from the tunable bandpass filter. The 2.9 - to 3.8-MHz low-frequency oscillator Q7 third injection frequency is applied to the base of receiver mixer Q6. The third injection frequency (2.9 to 3.8 MHz) differs from the second intermediate frequency either plus or minus 500 kHz. Second intermediate frequencies of 2.9 through 3.3 MHz have a third injection frequency of 3.4 through 3.8 MHz respectively. Second intermediate frequencies of 3.4 through 3.8 MHz have a third injection frequency of 2.9 through 3.3 MHz respectively. The collector output of Q6 (third intermediate frequency) is capacitively coupled to 500-kHz filter 1A3FL1 of 3rd if and squelch module. Refer to figure 5-87.

4. RELAY SWITCHING. - Relays K1, K2, and K3 of 1st and 2nd if amplifier module are energized during transmit operation. When relay K1 operates, voltage is applied through L1 to collector of Q4, capacitor C1 is removed from the input tuned circuit, and C33 is switched across the tuned circuit consisting of C2 and L1. Relay K2 switches the high-frequency oscillator output from 2nd receiver mixer Q3 to transmitter mixer Q4. By this operation, the emitter circuit of Q3 is opened and its base is grounded, biasing off the transistor. Relay K3 switches the rotors of S3. With K3 energized, the low-frequency oscillator frequency and center frequency of the second intermediate frequency are the same. In order to reduce low-frequency oscillator harmonics, this Q6 output is fed back through the tunable bandpass filter to the base of transmitter mixer Q4. During transmit operation, the low frequency oscillator Q7 signal is applied to the base of Q6, the output is taken from the emitter, and Q6 operates as a common collector amplifier.

(c) 3RD IF AND SQUELCH MODULE 1A3. - 3rd if and squelch module 1A3 consists of three 500-kHz if amplifier stages, two detectors, two direct-coupled avc amplifiers, and a 2-transistor carrier-operated squelch circuit. 3rd if and squelch module 1A3 receives a 500-kHz if signal from third receiver mixer Q6 in 1st and 2nd if amplifier module 1A2 and supplies a detected audio signal that is properly noise limited and controlled by a carrier-operated squelch system to impedance matching amplifier Q1 of audio module 1A4. An output of audio detector Q4 from 3rd if and squelch module 1A3 is supplied to the main receiver buffer amplifier where it is amplified and appears at J14 as an auxiliary audio signal. In addition, 3rd if and squelch module 1A3 supplies avc voltage for avc amplifier Q1 of rf and power amplifier module 1A8, supplies a positive avc voltage to amplifiers Q1 and Q2 of 3rd if and squelch module 1A3, and supplies a positive avc voltage to first if amplifier Q1 of 1st and 2nd if amplifier module 1A2. Refer to figure 5-87.

1. FILTER 1A3FL1 AND IF AMPLIFIERS Q1, Q2, AND Q3. - The 500-kHz if amplifier consists of filter FL1 and broadband amplifiers Q1, Q2, and Q3. An amplitude modulated if signal is fed to filter FL1 from third receiver mixer Q6 of 1st and 2nd if amplifier module 1A2. The bandpass of filter FL1 is approximately 80 kHz wide at the 6-dB points and provides the necessary selectivity for the if amplifier. The output of FL1 is amplified by three broadband amplifiers; two identical npn tetrode stages, Q1 and Q2; and npn triode stage Q3. The three amplifier stages are tuned by self-resonant, low-Q inductor collector loads L1, L2, and L3. The overall amplifier bandwidth is approximately 150 kHz. A positive-going voltage is applied to the number 2 bases of tetrode stages Q1 and Q2 for ave.

2. AUDIO DETECTOR Q4. - The output of third if amplifier Q3 is applied to audio detector Q4 (an npn silicon transistor). The collector load of this stage develops the audio for a diode noise limiter that clips the positive peak of any signal modulated more than the limits set by clipping adjustment R26. The limited output of audio detector Q4 is the audio output of 3rd if and squelch module 1A3. This output signal is applied through the volume control to the audio amplifier module and to J13 and J14 as the normal audio signal. This audio detector signal is also applied through the main receiver buffer amplifier to J14 as an auxiliary audio output.

3. AVC DETECTOR Q6. - The output of third if amplifier Q3 is also applied to the base of avc detector Q6. The collector load is a dc load that supplies the ave. Detector Q6 is a silicon pnp type transistor.

4. AVC AMPLIFIERS Q5 AND Q7. - The avc amplifier circuits consist of two transistor dc amplifiers, Q5 and Q7. Positive avc amplifier Q5 is an npn silicon transistor in a dc emitter follower circuit. The base signal for Q5 is obtained from avc detector dc load R21 and is a positive dc voltage. This voltage increases as the if signal to the detector increases, causing a positive-going avc voltage to be developed at the emitter of Q5. This positive-going avc voltage is fed to number 2 bases of Q1 and Q2 of 3rd if and squelch module 1A3 through diode gating circuit CR4 and to number 2 base of Q1 of 1st and 2nd if amplifier module 1A2. A portion of the positive avc voltage is also applied to the base of negative avc amplifier Q7 through gating diode CR5. The negative avc amplifier is a pnp silicon transistor in a common-emitter dc amplifier circuit with a negative collector supply voltage. As the positive base voltage increases, Q7 approaches cutoff, and the collector voltage approaches zero. This negative-going avc voltage is fed through gating diode CR2 to avc amplifier Q1 of rf and power amplifier module 1A8.

5. DC AMPLIFIER Q10 AND SQUELCH RELAY AMPLIFIER Q8. - The squelch circuit consists of dc amplifier Q10, squelch relay amplifier Q8, and squelch relay K1. Dc amplifier Q10 is a pnp silicon transistor, and squelch relay

amplifier Q8 is an npn silicon transistor. A portion of the positive avc emitter voltage, developed by positive avc amplifier Q5, is applied to the emitter of dc amplifier Q10. The collector of Q10 is direct coupled to the base of squelch relay amplifier Q8 that operates relay K1. The contacts of energized relay K1 remove the ground from the audio output 3rd if and squelch module 1A3. When SQUELCH control 1A9R5 is adjusted for maximum sensitivity (full cw), the avc voltage resulting from receiver noise will cause the squelch circuit to energize relay K1. As SQUELCH control 1A9R5 is progressively adjusted in the clockwise direction, the bias voltage developed at the cathode of gating diode CR8 increases, requiring an increase in input signal to develop adequate avc voltage to forward bias dc amplifier Q10 and consequently turn on squelch relay amplifier Q8, energizing squelch relay K1.

(d) AUDIO MODULE 1A4. - The audio output from 3rd if and squelch module 1A3 and guard receiver module 1A7 are applied across the main and guard input level control potentiometers 1A4R19 and 1A4R20, through volume control 1A9R4 on the front panel of Radio Receiver-Transmitter RT-695A/ PRC-41 to the base of audio amplifier 1A4Q1. The output of Q1 is fed through a low-pass filter, consisting of L2 and capacitor C4, to audio driver 1A4Q2 which is transformer coupled by audio transformer T1 to push-pull class B common-collector audio output transistors 1A4Q3 and 1A4Q4. The audio output from transistors Q3 and Q4 is fed through output transformer T2 to Handset H-33E/PT and is present at J14-J. Refer to figure 5-88.

(2) TEST DATA. - If the main receiver functional section has been determined defective, it is necessary to trace the signal path through the main receiver section. Perform the steps of procedure of table 4-4 to isolate the trouble to a defective circuit or circuit group. Refer to figure 4-19, servicing block diagram, and figure 4-1 for location of test points and signal flow of the main receiver functional section.

(a) TEST EQUIPMENT REQUIRED.

1. Oscilloscope AN/USM-105A.
2. Audio Oscillator TS-382B/U.
3. Signal Generator AN/USM-44A.
4. Signal Generator AN/URM-25D.
5. Electronic Multimeter TS-505/U.
6. Output Power Meter ME-2/U.
7. Signal Generator Pad CN-315/

URM-26.

8. Fuse MX-1730/U.

(b) TEST SETUP. - Set RT-695A/PRC-41 on the test bench with CY-3884/PRC-41 removed, and connect Power Supply PP-3700/PRC-41 to provide required primary power. Refer to figure 5-21. Connect junction box (figures 5-1 and 5-2), fabricated from bulk supplies, to KY-38 connector 1A9J14 on front panel of RT-695A/PRC-41.

(c) MAIN RECEIVER FUNCTIONAL SECTION CIRCUIT TROUBLE ISOLATION. - To determine which circuit or circuit group is defective, perform the steps of table 4-4 in sequence. After each preliminary action, compare indications obtained with the expected result in NORMAL INDICATION column. If indications are normal, proceed to the next step. If abnormal indications are observed, follow the procedures outlined in NEXT STEP column. Before performing the steps of table 4-4, set the VOL control on RT-695A/PRC-41 to maximum clockwise position and the SQUELCH control to maximum counterclockwise position. Set OFF-T/R-T/R/G-DIAL LIGHT switch to T/R and allow a 5-minute warmup period.

TABLE 4-4. MAIN RECEIVER FUNCTIONAL SECTION, TROUBLE ISOLATION

Step	TEST POINT	PRELIMINARY ACTION	NORMAL INDICATION	NEXT STEP
1	① KY-38 connector to 1A9J14 on front panel  ② Test jack 1A4J2 on audio module	Connect Output power Meter ME-2/U to NORMAL AUDIO OUTPUT on junction box. Connect Audio Oscillator TS-382B/U to test jack 1A4J1 on audio amplifier module set at 0.03-volt output at 1000 Hz. Connect Oscilloscope AN/USM-105 to test jack 1A4J2.	ME-2/U should indicate approx 50 milliwatts and a sine-wave signal should be observed on AN/USM-105A	If normal indications are not obtained, make voltage measurements on a audio module 1A4, (table 5-5). Remove audio module from main chassis and use extension cable W5 (figure 1-12 and table 1-4).
2	③ KY-38 connector on front panel	Disconnect wire from pin 1 of 3 <sup>rd</sup> if and squelch module connector 1A9J7. Connect coaxial extension	ME-2/U should indicate approximately 10 milliwatts.	If normal indications are not obtained, make voltage measurements on 3 <sup>rd</sup> if and squelch
(Cont.)				

**TABLE 4-4. (Continued)**

Step	TEST POINT	PRELIMINARY ACTION	NORMAL INDICATION	NEXT STEP
2		cable W7 and coaxial connector adapter A1 (figure 1-12 and table 1-4) to pin 1 of connector 1A9J7 and chassis ground. Connect - Signal Generator AN URM-25D, to adapter A1 set to 500 kHz, modulated 30% with 1000 Hz, with a signal output of 50 microvolts Connect TS-505/U to test Jack 1A3J1 A maximum indication on TS-505/U will indicate correct signal generator frequency in this and succeeding steps.		module 1A3 (table 5-4). Remove 3rd if and squelch module from main chassis and use extension cable W4(figure 1-12 and table, 1-4).
3	Same as step 2	Disconnect extension cable W7 from pin 1 of 1A9J7 and reconnect wire removed this pin in step 2 Remove plug 1A9P2 from jack 1A8J17 on transmit-receive coaxial switch in main chassis. Connect Signal Generator AN/USM-44A to plug 1A9P2 using coaxial adapter A1 Set AN/USM-44A to 29.9 MHz, modulated 30% with 1000 Hz, with a signal output of 50 microvolts. Set frequency control knobs on front panel of RT-695A/ PRC-41 to 399 9 MHz Progressively change frequency of AN/USM-44A to 28.8, 27 7, 20 0 MHz and RT-695A/PRC-41 frequency control knobs to 398.8, 397 7 . 390 0 MHz.  Progressively change frequency of AN/USM-44A to 28.8; 27.7; ..... 390.0 MHz.	ME-2/U should indicate approx 20 milliwatts. If normal indication is obtained on all combinations of test frequencies, proceed to step 7.	If normal indication is not obtained on all test frequencies, proceed to step 4.
4	③ Test jack 1A2J2 on 1 <sup>st</sup> and 2 <sup>nd</sup> if amplifier module	Connect TS-505/U to test jack 1A2J2. Rotate 10-MHz frequency control knob on front panel of RT-695A/ PRC-41 to all 10 positions (9, 8, 0).	Measure -2.5 to -4.0 volts dc on each position of 10-MHz knob.	If normal indication is not obtained measure voltages of transistor 1A2Q7 given in table 5-3. Transistor 1A2Q7 is accessible through opening on top side of 1st and 2nd if amplifier module. Remove module side cover and visually check switch 1A2S3 for bent contact arms.

**TABLE 4-4. (Continued)**

Step	TEST POINT	PRELIMINARY ACTION	NORMAL INDICATION	NEXT STEP
5	④	Connect TS-505/U to test jack 1A2J1. Rotate 1-MHz frequency control knob on front panel of RT-695A/PRC-41 to all 10 positions (9, 8, ., . 0).	Measure -0.5 to -1.5 volts dc on each position of 1-MHz knob.	If normal indication is not obtained, remove module side cover, and measure transistor 1A2Q5 given in table 5-3. Check setting of inductors 1A2L9 through 1A2L18 (17.1- to 26 1-MHz oscillator tuning slugs) according to procedure of paragraph 5-3b.
6	None	Remove 1st and 2nd if amplifier module 1A2 from main chassis, remove side covers and end cover, and connect module to main chassis using extender cable W2	Measure voltages given in table 5-3.	If indications of table 5-3 are not obtained, isolate defective detail part by indication of voltage measurements.
7	② Filament circuit test jack 1A9J25	Connect TS-505/U to test jack 1A9J25 on rear plate of main chassis.	Measure +6.3 volts dc.	If correct indication is not obtained, check individual tube filaments in rf and power amplifier module 1A8 and spectrum generator module 1A5.
8	⑤ Test jack 1A5J2 on spectrum generator module 1A5	Connect TS-505/U to test jack 1A5J2. Rotate tens hundreds-MHz frequency control knob on front panel of RT-695A/PRC-41 to all 18 positions, (39, 38, ... 22).	Measure -1.5 to -5 volts dc. If normal indication is obtained on all frequencies, proceed to step 10.	If normal indication is not obtained, proceed to step 9.
9	① Test jack 1A5J1 on spectrum generator module 1A5	Connect TS-505/U to test jack 1A5J1. Switch tens-hundreds-MHz frequency control knob on front panel of RT-695A/PRC-41 to all 18 positions, (39, 38, . 22).	Measure -5 to -20 volts dc. If normal indication on all frequencies, is obtained, proceed to step 10.	If normal indication is not obtained, proceed to step 9.
10	None	Remove spectrum generator module 1A5 from main chassis, and remove four side covers. Connect module to main chassis using extension cable W3	Measure voltages given in table 5-6.	If indications of table 5-6 are not obtained, isolate defective detail part by indication of voltage measurements given in table 5-7.

**TABLE 4-4. (Continued)**

Step	TEST POINT	PRELIMINARY ACTION	NORMAL INDICATION	NEXT STEP
11	None	Close switch S1 on junction box while observing action of transmit relay 1A9L9 on switch Open switch S1 on junction box while observing action of receive relay 1A9L7 on transmit-receive coaxial switch.	Transmit relay 1A9L6 shall rotate 45 degrees and return to original position very rapidly when switch S1 is closed Rotate armature of 1A9L9 manually 45 degrees in clockwise direction and release This shall cause no effect Armature shall rotate easily with no load except return spring. Receive relay 1A9L7 shall function same as 1A9L9 when switch S1 on junction box is opened.	If normal Indication is not obtained, check 26.5volts dc to 1A9L9 and 1A9L7 with switch S1 on junction box closed and opened respectively. Check switches S1A and S1B for continuity and first mixer for defective components (figure 4-6).
12	Same as step 2	Replace plug 1A9P2 on jack 1A9J17 Disconnect plug 1A9P7 from Jack 1A9J19 on transmit-receive coaxial switch Connect AN/ adapter A2, extension coaxial cable W6, and coaxial connector adapter A1. Set AN/USM-44A to 399.9 MHz, modulated 30% with 1000 Hz, with an output of 5 microvolts. Set frequency control knobs on front panel of RT-695A/PRC-41 to 399.9-MHz	ME-2/U should indicate approximately 30 milliwatts If normal indication is obtained, proceed to step 14	If normal Indication is not obtained, proceed to step 13
13	None	Remove rf and power amplifier-module 1A8 from main chassis, remove four covers, and connect module to main chassis using extension cable W1 and coaxial extension cable W8.	Measure voltages given in table 5-10.	If Indication is not obtained, isolate detail defective part by indication of voltage measurements and use of resistance measurements (table 5-11).
14	Same as step 2	Replace plug 1A9P2 on jack 1A9J17. Remove plug 1A9P9 from jack 1A9J22 on bandpass filter 1A9FL8 modulated 30% with 1000 Connect AN/USM-44A to plug 1A9P9 using coaxial connector adapter A1. Set AN/USM-44A to 399.9 MHz modulated 100 Hz with an output of 5 microvolts.	ME-2/U should indicate approximately 20 milliwatts.	If normal Indication is not obtained, check transmit-receive switch S1A for continuity from 1A9J21 to 1A9J19



**TABLE 4-4. (Continued)**

Step	TEST POINT	PRELIMINARY ACTION	NORMAL INDICATION	NEXT STEP
15	Same as step 2	Replace plug 1A9P9 on jack 1A9J22. Connect AN USM-44A to antenna connector 1A9J28 Set AN/ USM-44A to 399.9 MHz modulated 30% with 1000 Hz.	ME-2/U should indicate approximately 20 milliwatts	If normal indication is not obtained check antenna connector, cables, and bandpass filter 1A9FL8 for continuity or shorts. Filter 1A9FL8 does not have dc continuity from input to output.

#### 4-4. OVERALL GUARD RECEIVER FUNCTIONAL SECTION.

a. DESCRIPTION. (Refer to figure 4-19.) -The guard receiver functional section is composed of circuits of guard receiver module 1A7 along with switching and interwiring of the main chassis of Radio Receiver-Transmitter RT-695A/PRC-41. The guard receiver module uses the same antenna and final audio amplifier stages as the main receiver functional section but has its own squelch, detector, first audio amplifier, and avc stages. A strong signal on the main channel will not affect the sensitivity of the guard receiver, providing the main receiver is not set to 243.0 MHz. The guard receiver frequency can be changed (in the range of 238 to 248 MHz) by changing the guard injection oscillator crystal and returning the rf tuned circuits. The guard receiver module is a single-conversion superheterodyne receiver normally fixed tuned to 243.0 MHz. The audio output is applied to the guard input level control potentiometer in audio module 1A4, amplified by stages of the audio module, and applied to Handset H-33E/PT. The guard receiver audio output is also applied to guard audio buffer amplifier 1A9A2 in the main chassis where it is amplified and appears at KY-38 connector 1A9J14-S as a low level auxiliary guard output. The rf input signal from contacts of receiver-transmit switch 1A9S1 is fed to two stages of rf amplification. The output URM-26. Of the rf amplifier stages is fed to transistor mixer Q3 where the 243.0-MHz rf signal is mixed with an injection signal of 22.45 MHz from diode CR7 and tuned circuit L7, C22, and C23, which act as a frequency doubler for oscillator Q4. The difference between these two frequencies is selected to provide the 20.55-MHz intermediate signal. The output from transistor mixer Q3 is coupled through coupling capacitor C21 to first if amplifier Q5. The output of Q5 is coupled to second if amplifier Q6 through crystal filter FL1. Q7, Q8, and Q9 are the third, fourth, and fifth if amplifiers. The output of these if amplifier stages is fed to detector Q10 which serves as both an audio detector and an avc detector. The audio output from the detector is applied to audio 4-20 amplifier Q15. The output from audio amplifier Q15 is fed to the guard input level control in the audio module and to the guard audio buffer amplifier. The output from detector Q10 is applied to avc amplifier Q11. The output from Q11 provides avc voltage to the first, second, and third if amplifier stages to rf avc amplifier Q12 and to squelch amplifier Q13.

b. TEST DATA. - In order to determine whether or not the guard receiver functional section is faulty, perform the test procedures of paragraph 4-4b(3). If the results of the performance test prove the guard receiver functional section to be operative, proceed to the next functional section performance test to locate the faulty functional section or sections. Steps (1) through (3) below provide the necessary test data to aid in pinpointing or eliminating the functional section under consideration. Refer to the guard receiver functional section of the servicing block diagram (figure 4-19) for location of test points, signal flow, and auxiliary circuits such as power distribution and control. To determine whether the guard receiver functional section is operative, connect RT-695A/PRC -41 into the test setup described in step (2) and subject the equipment to guard receiver functional section performance test.

(1) TEST EQUIPMENT REQUIRED.

- (a) Signal Generator AN/USM-44A.
- (b) Signal Generator Pad CN-315/  
URM-26
- (c) Fuse MX-1730/U.
- (d) Output Power Meter ME-2/U.

(2) TEST SETUP. - Set RT-695A/PRC-41 on the test bench, and connect Power Supply PP-3700/ PRC-41 to provide the required primary power. Connect AN/USM-44A in series with Signal Generator Pad CN-315/URM-26, MX-1730/U, and a length of RG213/U coaxial cable to antenna connector 1A9J28 on the RT-695A/PRC-41. Connect the junction box (figures 5-1 and 5-2) to the KY-38 connectors 1A9J14 on the front panel of RT-695A/PRC-41. Connect ME2/U to the NORMAL AUDIO OUTPUT connector on the junction box. Set VOL and SQUELCH controls on the front panel of RT-695A/PRC-41 to maximum clockwise position.

**(3) FUNCTIONAL SECTION PERFORMANCE TEST.****CAUTION**

Be careful not to key Radio Receiver-Transmitter RT-695A/PRC-41 with Signal Generator AN/USM-44A connected to antenna connector J28. Fuse MX-1730/U provides protection for the signal generator attenuator in the event the RT-695A/PRC41 is accidentally keyed.

- (a) Set AN/USM-44A to 243.0 MHz, modulated 30 percent with 1000 Hz, with an output level of 1000 microvolts.  
 (b) Set OFF-T/R-T/R/G-DIAL LIGHT switch to T/R/G. Turn on AN/USM-44A, and allow equipment time to warm up. Carefully adjust AN/ USM-44A signal output about 243.0 MHz to obtain maximum indication on ME-2/U.  
 (c) Audio power output should be 50 milliwatts minimum. If this result is not obtained, the guard receiver functional section is defective.

c. **GUARD RECEIVER CIRCUIT DESCRIPTION.** As a further aid in explanation of the guard receiver functional section, each circuit making up a functional section is discussed in the order of signal flow. Only circuits which are uncommon (those not covered in the Handbook of Electronic Circuits, NavShips 900, 000.102) will be discussed. See the schematic diagram (figure 5-91) and the servicing block diagram (figure 4-19). Test data is provided to aid in isolation of trouble to a circuit or group of circuits. Refer to the applicable tuning and adjustment procedures of paragraph 5-3a. Perform these procedures only when necessary or following repair as required.

(1) **FUNCTIONAL DESCRIPTION.** - The guard receiver functional section consists of the circuits of guard receiver module 1A7 and switching and interwiring of the main chassis of RT-695A/ PRC-41. Audio output of the guard receiver module is amplified by audio module 1A4 and applied to H33E/PT. Discussion of circuits of the guard receiver functional section is presented by circuit in order of signal flow. See the guard receiver functional section block diagram of the servicing block diagram (figure 4-19) as an aid in understanding the theory of operation of guard receiver functional section, and refer to figure 5-91 also.

(a) **GUARD RECEIVER MODULE 1A7.** A 243.0-MHz signal appearing on either Antenna AS-1404/PRC-41 or Antenna AS-1405/PRC-41 is fed through antenna connector 1A9J28 and through receive-transmit switch 1A9S1A to input of the guard receiver module at connector 1A9J9A1.

1. **RF AMPLIFIERS Q1 AND Q2.** The guard receiver module rf amplifiers consist of transistor stages Q1 and Q2. The guard receiver rf input signal is applied to the base of first rf amplifier Q1 through a parallel-tuned circuit, consisting of inductor L1 and capacitors C1 and C2, and coupling capacitor C4. The amplified output of Q1 is taken from its collector, applied to a tuned circuit, consisting of inductor L2 and capacitors C6 and C7, and coupled through capacitor C9 to the base of second rf amplifier Q2. The amplified rf output is taken from the collector of Q2, applied to a parallel-tuned capacitive coupled circuit, coupled through capacitor C14 to another parallel-tuned circuit, and coupled through capacitor C17 to the base of mixer Q3. Collectors of rf amplifiers Q1 and Q2 are connected to the avc output taken from collector of rf avc amplifier Q12.

2. **OSCILLATOR Q4.** - The output of rf amplifiers Q1 and Q2 is fed to mixer Q3 where the 243.0-MHz rf signal is mixed with the injection signal of 222.45 MHz to obtain the 20.55-MHz intermediate frequency signal. The injection signal is developed by grounded base crystal oscillator Q4 using a fifth overtone crystal. This frequency is doubled by frequency doubler CR7 and tuned circuit L7, C22, and C23 and is applied to mixer Q3. The mixer is followed by a 5-stage tuned if amplifier using tetrode transistors.

3. **IF AMPLIFIERS Q5, Q6, Q7, Q8, AND Q9.** - The 20.55-MHz if signal is taken from transistor mixer Q3 and applied through coupling capacitor C21 to the base of first if amplifier Q5; Resonating inductors L11 through L15, connected to the collectors of if amplifiers Q5 through Q9 respectively, are tuned to 20.55 MHz. Intermediate-frequency amplifiers Q5, Q6, and Q7 are controlled by the positive avc connected to their number 2 bases. The number 2 base of if amplifier Q8 is connected to squelch potentiometer R46. Adjustment of R46 changes the bias voltage on number 2 base of Q8 thus varying the squelch operating level. If amplifier Q9 output is capacitively coupled to the base of detector Q10.

4. **DETECTOR Q10.** - The amplified if output from fifth if amplifier Q9 is detected by class B operated detector Q10. The detected audio signal is taken from the collector of Q10 and applied to the base of audio amplifier Q15 and to the collector of squelch amplifier Q13 through noise limiter diode CR2. The collector output from detector Q10 is also applied to the base of avc amplifier Q11, providing a positive avc output.

5. **AUDIO AMPLIFIER Q15 AND SQUELCH AMPLIFIER Q13.** - The detected audio out-put from Q10 is amplified by audio amplifier Q15. The amplified output from the collector of audio amplifier Q15 is applied to audio amplifier 1A4Q1 of the audio module. Squelch amplifier Q13 biases off audio amplifier transistor Q15 when there Carrier signal being received on the guard channel. The emitter of audio amplifier Q15 has a fixed bias of approximately 17 volts. Under no-signal condition, the base bias of Q15 is approximately 18 volts. When a signal appears on the guard channel, the avc voltage from avc amplifier Q11 begins to rise. Due to the rise in avc voltage,

the base bias voltage of squelch amplifier Q13 rises and overcomes the fixed bias provided the emitter of squelch Q13 by zener diode CRT. The squelch amplifier then conducts and draws collector current. This lowers the base bias on audio amplifier Q15 and causes it to conduct. Audio amplifier Q15 collector current then raises the base bias of squelch amplifier Q13 to hold the circuit on. When the carrier input is removed from the guard receiver module, the action is reversed. The avc voltage drops, squelch amplifier Q13 becomes biased off, and stops conducting. This action makes the base bias of audio amplifier Q15 rise and it also stops conducting. The absence of collector current of Q15 then lowers the base bias of squelch amplifier Q13 to hold the circuit off. 6. AVC AMPLIFIERS Q11 AND Q12.- Two avc voltages are used to control the gain of the guard receiver module. The first is a positive avc voltage applied to three if amplifier stages and to the base of squelch amplifier Q13 to squelch the audio output of Q15 when no signal is being received. The second is a decreasing positive avc voltage applied to the collectors of the first and second rf amplifiers and mixer. Test jack 1A7J2 provides a test point for measurement of avc amplifier Q11 avc voltage. Zener diode CR3 establishes a voltage reference level that must be exceeded by strength of input signal before avc amplifier Q12 is permitted to provide avc voltage to the rf amplifiers.

(2) TEST DATA. - If the guard receiver functional section has been determined defective, trace the signal path through the guard receiver module to locate the defective circuit or circuit group. To isolate trouble within the guard receiver functional section. perform the steps of table 4-5. Refer to figure 4-1 and the servicing block diagram figure 4-19 for location of test points and signal flow of guard receiver functional section.

- (a) TEST EQUIPMENT REQUIRED.
1. Oscilloscope AN/USM-105A.
  2. Signal Generator AN/USM-44A.
  3. Signal Generator Pad CN-315/

URM-26.

4. Fuse MX-1730/U.
5. Electronic Multimeter TS

505/U.

(b) TEST SETUP. - Set RT-695A/PRC41 on the test bench with CY-3884/PRC-41 removed, and connect PP-3700/PRC-41 to provide required primary power. See figure 5-21. Connect junction box (figures 5-1 and 5-2) to KY-38 connector 1A9J14 on front panel of RT-695A/PRC-41.

(c) GUARD RECEIVER FUNCTIONAL SECTION CIRCUIT TROUBLE ISOLATION. - To determine which circuit or circuit group is defective, perform the steps of table 4-5 in the sequence listed. After each preliminary action. compare the indications obtained with the expected result in the NORMAL INDICATION column. If the indications are normal, proceed to the next step. If abnormal indications are observed, follow the procedures outlined in the NEXT STEP column. Before performing the steps of table 4-5, set the VOL and SQUELCH controls on front panel of RT-695A/PRC-41 to maximum clockwise. Set OFF-T/R-T/R/G-DIAL LIGHT switch to T/R/G.

**TABLE 4-5. GUARD RECEIVER FUNCTIONAL SECTION, TROUBLE ISOLATION**

Step	TEST POINT	PRELIMINARY ACTION	NORMAL INDICATION	NEXT STEP
1	<p>③KY-38 connector 1A9J14 on front panel and NORMAL AUDIO OUTPUT jack on junction</p> <p>②Test jack 1A4J2 on audio module</p>	<p>Connect ME-2/U to NORMAL AUDIO OUTPUT jack on junction box.</p> <p>Connect An/USM-105A to test jack 1A4J2. Remove guard receiver module 1a7 from main chassis, remove side covers, and connect the module to main chassis using extension cable W3. Connect AN/USM-44A through a 10 pF capacitor to base number 1 of extension cable W7 and coaxial adapter A1. Set AN/USM-44A to 20.55 MHz, modulated 30% with 1000 Hz, with an output level of 500 microvolts.</p>	<p>ME-2/U indicate approximately 20 milliwatts, and a sinewave signal should be USM-105A.</p>	<p>If normal indication is not obtained, check operation of audio module according to step 1 of table 4-4. If audio module is functioning properly, proceed to step 2.</p>

**TABLE 4-5. (Continued)**

Step	TEST POINT	PRELIMINARY ACTION	NORMAL INDICATION	NEXT STEP
2	Same as step 1	Same as step 1	Measure voltages given in table 5-9 for guard receiver transistors Q5 through Q15	If indications of table 5-9 are not obtained, isolate defective detail part by indications of voltage measurements.
3	⑦ Test jack	Connect TS-505/U to test jack 1A7J1.	Measure -1 to -3 volts dc	If normal indication is not obtained, measure voltages of oscillator transistor Q4 given in table 5-9. Check setting of inductor L10 according to procedure of paragraph 5-3 b(3)(e).
4	1A7J1 on guard receiver module  NORMAL AUDIO OUTPUT jack on junction box	Remove AN/USM-44A and 10-pF capacitor from base number 1 of Q5 Disconnect plug 1A9P4 from jack 1A9J19 on transmit receive coaxial switch. Connect AN/USM-44A to plug 1A9P4 using coaxial connector adapter A1. Set AN/USM-44A to 243 0 MHz, modulated 30% with 1000-Hz, with an output level of 10 microvolts	ME-2/U should indicate approximately 20 milliwatts.	If normal indication is not obtained, measure voltages on rf amplifier transistors Q1 and Q2 and mixer transistor Q3 (table 5-9)
5	Same as step 4.	Disconnect AN/USM-44A from plug 1A9P4 Reconnect plug 1A9P4 to jack 1A9S1 receive coaxial switch. Connect AN/USM-44A to antenna connector 1A9J28. Set AN/USM-44A to 243 0 MHz, modulated 30% with 1000 Hz, with an out put level of 10 microvolts. Set frequency control knobs on front panel of RT-695A/PRC-41 to any frequency other than 243 0 +5 MHz.	ME-2/U should indicate approximately 20 milliwatts.	If normal indication is not obtained, check continuity of transmit from jack 1A9J21 to Jack 1A9J20.. Check antenna connector 1A9J28 and coaxial cables for continuity or shorts

**4-5. OVERALL TRANSMITTER FUNCTIONAL SECTION.**

a. DESCRIPTION. (Refer to figure 4-5.) - The transmitter functional section is composed of circuits of the modulator, rf and power amplifier, and 1st and 2nd if amplifier modules along with switching and interwiring of the main chassis of RT-695A/PRC-41.

The transmitting circuits use, with some switching differences in the 2.9- to 3.8-MHz crystal circuits, the same crystal-controlled frequency generating circuits as the main receiver. Refer to figure 4-11. In transmit operation, the 2.9- to 3.8-MHz injection frequency is the same as the second intermediate frequency. The 2.9- to 3.8-MHz low-frequency injection oscillator frequencies of 1st and 2nd if amplifier

module is mixed with high-frequency injection oscillator frequencies to produce rf signals between 20 and 29.9 MHz. The 20- to 29.9-MHz signals are amplified in the 20- to 29.9-MHz if amplifier stages of 1<sup>st</sup> and 2nd if amplifier module and applied through contacts of receiver-transmit switch 1A9S1B to diode mixer 1A9CR1. The 20- to 29.9-MHz signals are mixed with the 200- to 370-MHz signals from spectrum generator module in diode mixer 1A9CR1 to produce a carrier between 225.0 and 399.9 MHz. An audio input signal from H-33E/PT is applied to the input of modulator module. Output from the modulator module is applied to the driver and power amplifier stages of rf and power amplifier module. The carrier is modulated in the driver and power amplifier stages of the rf and power amplifier module by audio from modulator module and applied to the antenna for radiation. All tunable circuits in the transmitter functional section are mechanically linked to three control knobs located on the front panel of RT-695A/PRC-41.

b. TEST DATA. - In order to determine whether the transmitter functional section is faulty, perform the test procedures of step (3) of this paragraph. If results of the performance test prove the transmitter functional section to be operative, proceed to the next functional section performance test to locate the faulty functional section or sections. Steps (1) through (3) below provide the necessary test data to aid in pinpointing or eliminating the functional section under consideration. Reference is made to the transmitter functional section of the servicing block diagram (figure 4-19) and to figure 4-1 for location of test points, signal flow, and auxiliary circuits such as control and frequency generation. To determine whether the transmitter functional section is operative, connect RT-695A/PRC-41 into test setup described in paragraph 4-5b(2), and subject the equipment to transmitter functional section performance test.

(1) TEST EQUIPMENT REQUIRED. - The required test equipment is RF Wattmeter AN/URM-43C.

(2) TEST SETUP. switch to T/R. MHz.H- 33E/PT.- Set RT-695A/PRC-41 on the test bench with CY-3884/PRC-41 removed, and connect PP-3700/PRC-41 to provide required primary power. Refer to figure 5-21. Connect AN/URM-43C to antenna connector 1A9J28 on RT-695A/PRC-41, test point 5. Connect H-33E/PT to the H33E/PT connector on front panel of RT-695A/PRC-41.

(3) FUNCTIONAL SECTION PERFORMANCE TEST.

(a) Set OFF-T/R-T/R/G-DIAL LIGHT

(b) Set frequency selector knobs to 225.0

(c) Push press-to-talk switch on

(d) Measure power output at 225.0 MHz. Reset RT-695A/PRC-41 to 304.7 and 399.9 MHz. Power output should be 3 watts average across range.

c. TRANSMITTER CIRCUIT DESCRIPTION. As a further aid in explanation of the transmitter functional section, each circuit making up the functional section is discussed in order of signal flows. Only circuits that are uncommon (those not covered in the Handbook of Electronic Circuits, NavShips 900,000.102) will be discussed. See schematic diagrams of section 5 and the transmitter functional section and servicing block diagrams of this section. Test data is provided to aid in isolation of trouble to a module and then to a circuit or group of circuits. Refer to the applicable tuning and adjustment procedures of paragraph 5-3. Perform these procedures only when necessary or following repair as required.

(1) FUNCTIONAL DESCRIPTION. - The transmitter functional section is composed of circuits of the modulator, rf and power amplifier, and 1st and 2nd if amplifier modules along with switching and interwiring of the main chassis. Discussion of circuits of the transmitter functional section is presented by module in order of signal flow. See transmitter functional section block diagram (figure 4-5) as an aid in understanding theory of operation of the transmitter functional section.

(a) 1ST AND 2ND IF AMPLIFIER MODULE 1A2. - The 1st and 2nd if amplifier module has some of its stages used in both receive and transmit operation. With RT-695A/PRC-41 in transmit operation, the third receiver mixer and transmitter buffer, transmitter mixer, and two if amplifier stages of 1st and 2nd if amplifier module are used. The low- and high-frequency oscillator stages provide required injection frequencies. Refer to paragraph 4-6f for a description of the frequency generation circuits.

1. THIRD RECEIVER MIXER AND TRANSMITTER BUFFER Q6. - In transmit operation, low-frequency oscillator Q7 is shifted 500 kHz in frequency from that of receive operation. Transistor Q6, used as the third receiver mixer in receive operation, acts as a common collector amplifier in transmit operation and applied 2.9- to 3.8-MHz low-frequency oscillator Q7 signal to a tunable bandpass filter. This filter consists of inductors L19 through L24 and capacitors C24 through C28, C52, and C53. The output from the bandpass filter is capacitively coupled to base number 1 of first transmitter mixer Q4. During transmit operation, relay 1A2K2 removes high-frequency oscillator Q5 injection from second receiver mixer Q3 and applies it to the emitter of first transmitter mixer Q4. Relay K2 removes emitter voltage from second receiver mixer Q3 and grounds the base of Q3 at the same time. This prevents feedback through Q3 from collector to base number 1.

2. TRANSMITTER MIXER Q4. During transmit operation, transmitter mixer Q4 has voltage applied to its collector, high-frequency oscillator Q5 signal output, 17.1 to 26.1 MHz, to its emitter, and low-frequency oscillator Q7 output, 2.9 to 3.9 MHz, to its base. The sum of these mixed frequencies, 20 to 29.9 MHz, is the first immediate frequency and is fed to the 20- to 29.9-MHz if amplifiers, consisting of transistors Q1 and Q2 and their associated parallel tuned circuits. Capacitor C33 tunes the output of Q4

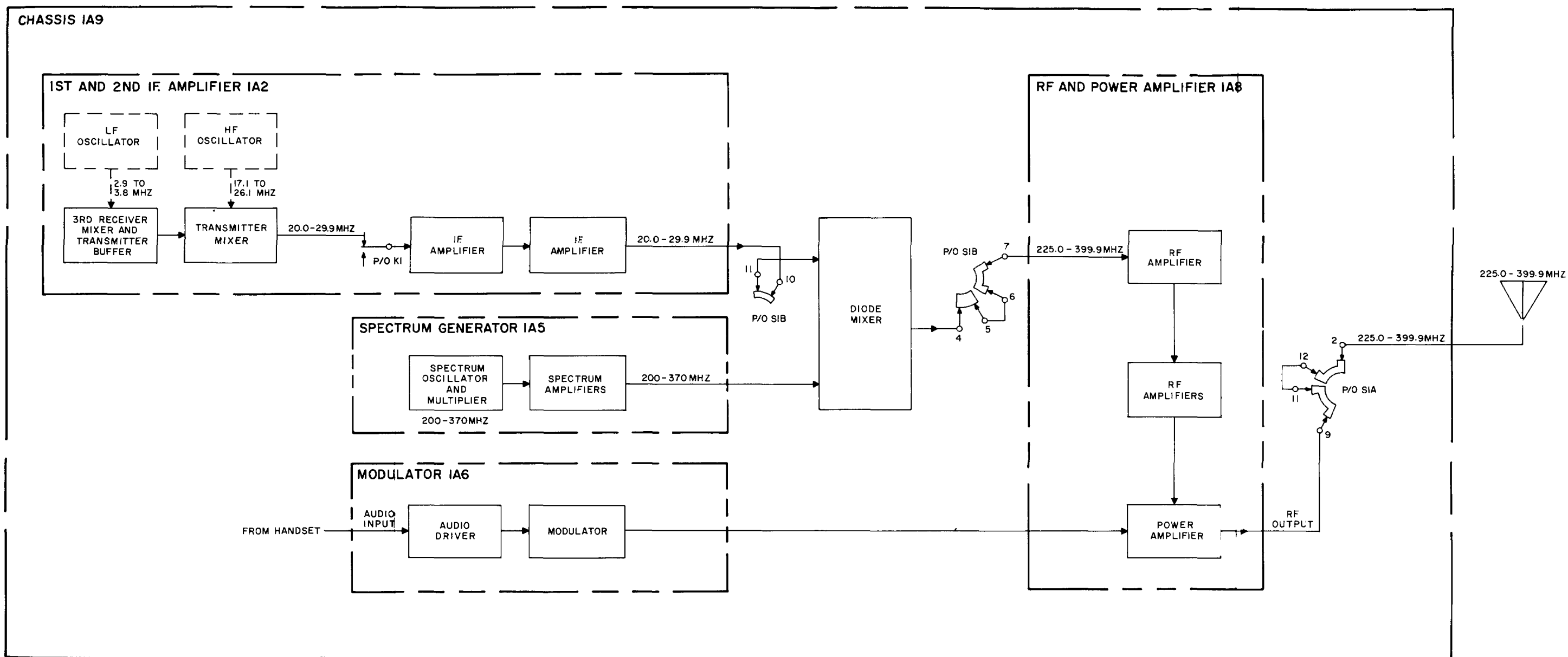

Figure 4-5. Radio Receiver-Transmitter RT-695A/PRC-41, Transmitter Functional Section Block Diagram

so the input circuit of Q1 is tuned in both receive and transmit operations (C1 is removed during transmit).

3. IF AMPLIFIERS Q1 AND Q2 AND SECOND TRANSMITTER MIXER 1A9CR1. With receive-transmit relay 1A2K1 in transmit position, the 20- to 29.9-MHz if signal from transmitter mixer Q4 is fed to if amplifiers Q1 and Q2. These amplifiers consist of three sets of capacitive coupled parallel-tuned circuits and transistors Q1 and Q2. The 20- to 29.9-MHz signal is applied to a parallel tuned circuit consisting of capacitor C2 and inductor L1 and is coupled by capacitor C3 to second tuned circuit. The second tuned circuit consists of capacitor C5 and inductor L2. The signal is then applied through coupling capacitor C4 to base number 1 of tetrode transistor if amplifier Q1. The output from collector of Q1 is applied to a parallel-tuned circuit consisting of capacitors C8 and C9 and inductor L3. The signal is then coupled through capacitor C10 to a parallel-tuned circuit consisting of capacitor C12 and inductor L4 and applied through coupling capacitor C56 to the base of if amplifier Q2. The output from collector of Q2 is applied to a parallel-tuned circuit consisting of capacitors C15 and C16 and inductor L5. The signal is then coupled through capacitor C17 to a parallel-tuned circuit consisting of capacitor C20 and inductor L6, through capacitor C21 to the output of the 1st and 2nd if amplifier module. This output is fed through contacts of receive transmit switch 1A9S1B to diode mixer 1A9CR1 (the second transmitter mixer). In diode mixer 1A9CR1, the 20 to 29.9-MHz first transmitter intermediate frequency is mixed with the 200- to 370-MHz output from spectrum generator module (refer to paragraph 4-6f) to produce the final output frequency in the 225.0- to 399.9-MHz range.

(b) RF AND POWER AMPLIFIER MODULE 1A8. - With exception of the avc amplifier, the same stages of rf and power amplifier module are used in both receive and transmit operations. In receive operation, 225.0- to 399.9-MHz signals are applied through contacts of receive-transmit switch 1A9S1B to the input of rf amplifier stages of rf power amplifier module. In transmit operation, output signals in the 225.0- to 399.9-MHz range are taken from diode mixer 1A9CR1 and applied to first rf amplifier V1. Signals in this range are amplified by V2, V3, and V4 and applied to power amplifier V5 in the same way as in receive operation. Refer to paragraph 4-3c(1)(a)1. Output from the modulator module is applied to the plates of rf driver V4 and power amplifier V5. Power amplifier V5 output is fed through contacts of receive-transmit switch 1A9S1A to the antenna. Refer to paragraph 4-3c(1)(a)2.

(c) MODULATOR MODULE 1A6. - When the press-to-talk button on Handset H-33E/PT is pressed, RT-695A/PRC-41 is switched to transmit operation, and the audio signal from the microphone is applied to the input of the modulator module. The audio signal is coupled to the base of audio driver Q1. Amplified output from the collector of audio driver Q1 is transformer coupled through transformer T1 to the bases of push-pull modulator transistors Q2 and Q3. Resistor R9 sets the saturation level of transistors Q2 and Q3 so that both positive and negative peaks are clipped equally to establish the clipping level between 70- and 90-percent modulation. Output from Q2 and Q3 is taken from their emitters and transformer coupled through transformer T2 to the plates of driver amplifier V4 and power amplifier V5 in the rf and power amplifier module.

(2) TEST DATA. - If the transmitter functional section has been determined to be defective, it is necessary to trace the signal path through the transmitter section. Perform the steps of procedure of table 4-6 to isolate the trouble to a defective circuit or circuit group. Refer to the servicing block diagram (figure 4-19) and figure 4-1 for location of test points and signal flow of transmitter functional section.

(a) TEST EQUIPMENT REQUIRED.

1. RF Wattmeter AN/URM-43C.
2. Electronic Multimeter TS

505/U.

3. Audio Oscillator TS-382B/U.

(b) TEST SETUP. - Set RT-695A/ PRC-41 on test bench with the CY-3884/ARC-41 removed, and connect PP-3700/PRC-41 to provide required primary power (figure 5-21). Connect junction box (figures 5-1 and 5-2) to KY-38 connector 1A9J14 on front panel of RT-695A/PRC-41.

(c) TRANSMITTER FUNCTIONAL SECTION CIRCUIT TROUBLE ISOLATION. - To determine which circuit or circuit group is defective, perform the steps of procedure of table 4-6 in sequence. After each preliminary action, compare indications obtained with the expected result in the NORMAL INDICATION column. If the indications are normal, proceed to the next step. If abnormal indications are observed, follow the procedures outlined in the NEXT STEP column. Before performing the steps of table 4-6, set OFF-T/R-T/R/G-DIAL LIGHT switch to T/R, and allow 5-minute warmup period.

#### 4-6. OVERALL SUBORDINATE CIRCUITS.

a. DESCRIPTION. (Refer to figure 4-19.) - Subordinate circuits are those circuits which support the main functions (main receiver, guard receiver, and transmitter functional sections) of Radio Receiver-Transmitter RT-695A/PRC-41. These circuits are considered to be the buffer amplifier assembly, main chassis, primary power distribution, frequency generation, control, and antenna circuits. Because these circuits provide functions that are essentially separate, no attempt is made to balance one against the other or to provide an all-inclusive trouble isolation test for the overall subordinate circuits. In this paragraph, a description followed by test data for trouble isolation is provided for each subordinate circuit. Primary power required for operation may be

TABLE 4-6. TRANSMITTER FUNCTIONAL SECTION, TROUBLE ISOLATION

Step	TEST POINT	PRELIMINARY ACTION	NORMAL INDICATION	NEXT STEP
1	③  Test jack 1A2J2 on 1 <sup>st</sup> and 2 <sup>nd</sup> if amplifier module	Connect TS-505/U to test jack 1A2J2. Connect AN URM-43C to antenna connector 1A9J28 on front panel of RT-695A/PRC-41. Unless otherwise instructed, AN/URM-43C shall be connected to 1A9J28 for entire transmitter functional section tests. Set frequency control knobs on front panel of RT-695A/PRC-41 to 399.9-MHz. Close switch S1 on junction box. Rotate the tenth MHz frequency control knob to all ten positions, 9, 9, 0. Do not leave switch S1 closed for extended period of time. Open switch S1 after completion of each test.	Measure -2.5 to -4.0 volts dc on each position of 10-MHz knob.	If normal indication is not obtained, measure voltages of transistor 1A2Q7 given in table 5-3. Transistor 1A2Q7 is accessible through opening on top side of 1 <sup>st</sup> and 2 <sup>nd</sup> if amplifier modules. Remove module side cover, and visually check switch 1A3S3 for bent contact arms.
2	④  Test jack 1A2J1 on 1 <sup>st</sup> and 2 <sup>nd</sup> if amplifier module	Connect TS-505/U to test jack 1A2J1. Close switch S1 on junction box. Rotate 1 MHz frequency control knob to all ten positions 9,8, 0.	Measure -0.5 to -1.5 volts dc on each position of 1-MHz knob.	If normal indications is not obtained, remove module side cover, and measure voltages of transistor 1A2Q5 given in table 5-3. Check setting of inductors 1A2L9 through 1A2L18. (17.1 to 26.1-MHz oscillator tuning slugs) according to procedure of paragraph 5-3b.
3	③  Test jack 1A2J3 on 1 <sup>st</sup> and 2 <sup>nd</sup> if amplifier module	Connect TS-505/U to test jack 1A2J3. Close switch S1 on junction box.	Measure -0.5 to -2.0 volts dc. If normal indication is obtained, proceed to step 5.	If normal indication is not obtained, proceed to step 4.
4	None	Remove 1 <sup>st</sup> and 2 <sup>nd</sup> if amplifier module 1A2 from main chassis, remove side covers, and connect the module to main chassis, remove side covers, and connect the module to main chassis using extension cable W2. Close switch S1 on junction box.	Measure voltage given in table 5-3 for transistors Q1, Q2, Q4, and Q6.	If indications of table 5-3 are not obtained, isolate defective detail part by indication of voltage measurements.



**TABLE 4-6. (Continued)**

STEP	TEST POINT	PRELIMINARY ACTION	NORMAL INDICATION	NEXT STEP
5	22 Test jack 1A9J27 on transmit-receive switch in main chassis	Replace 1st and 2nd if amplifier module 1A2 in main chassis. Connect TS-505/U to test jack 1A9J27 located on side of transmit-receive coaxial switch in main chassis. Close switch S1 on junction box.	Measure +0.5 to +2.0 volts dc.	If normal indication is not obtained, check spectrum generator module 1A5 according to the procedure of steps 5, 6, and 7 of table 4-10.
6	9 Test point 1A8J7 on rf amplifier receiver and transmitter module	Connect TS-505/U to test jack 1A8J7 on rf and power amplifier module 1A8. Close switch S1 on junction box.	Measure +1.2 to +1.8 volts dc. If normal indication is obtained, proceed to step 8.	If normal indication is not obtained, proceed to step 7.
7	None	Remove rf and power amplifier module 1A8 from main chassis, remove covers, and connect module to main chassis using extension cable W1 and coaxial extension cable W8. Close switch on junction box.	Measure voltages given in table 5-10	If indication of table 5-10 are not obtained, isolate defective detail part by indication of voltage measurements and use of resistance measurements given in table 5-11.
8	None	Replace rf and power amplifier module 1A8 in main chassis. Remove plug 1A9P9 from jack 1A9J22 on bandpass filter 1A9FL1 in main chassis. Connect AN/URM-43C to plug 1A9P9 using coaxial cable W6 and coaxial connector adapter A1. Close switch S1 on junction box.	Measure at least 3 watts average across the frequency range of 225.0 to 399.9 MHz.	If normal indication is not obtained, set OFF-T/R-T/R/G- DIAL LIGHT switch to OFF with switch S1 on junction box closed. Check continuity of transmit-receive switch 1A9S1A by measuring zero resistance from 1A9J16 to 1A9J21.
9	5	Connect AN/URM-43C to antenna connector 1A9J28 on front panel of RT-695A/PRC-41. Replace plug 1A9P9 on jack 1A9J22 on bandpass filter 1A9FL1. Close switch S1 on junction box.	Measure at least 3 watts average across the frequency range of 225.0 to 399.9 MHz.	If normal indication is not obtained, check antenna connector 1A9J28, bandpass filter 1A9FL1, and coaxial cables for continuity or shorts. Bandpass filter 1A9FL1 does not have a dc path from input to output.
10	11 Test jack 1A6J2 on modulator module	Connect TS-382B/U to MIC INPUT jack on junction box. Connector TS-505/U to MIC INPUT OPEN CIRCUIT jack on junction box. Set TS-382B/U to 1000 Hz with an output level to indicate 0.7 volt ac on TS-505/U to test jack 1A6J2 on modulator module 1A6. Close switches S1 and S2 on junction box.	Measure 8 to 10 volts ac.	If normal indication is not obtained, proceed to step 11.

**TABLE 4-6. (Continued)**

STEP	TEST POINT	PRELIMINARY ACTION	NORMAL INDICATION	NEXT STEP
11	None	Remove modulator module 1A6 from main chassis, remove cover, and connect module to main chassis using extension cable W5. Audio oscillator shall be set same as for step 10. Close switches S1 and S2 on junction box.	Measure voltages on audio driver transistor Q1 and modulator transistors Q2 and Q3 given in table 5-8.	If normal indications are not obtained, isolate defective detail part by indication of voltage measurements.

obtained from Storage Battery BB-451/U, Power Supply PP-3700/PRC -41, or from an aircraft or vehicular power source. Power distribution circuits are common to the three main functional sections. Frequency generation circuits are common to both main receiver and transmitter functional sections. Control circuits are inclusive of mechanical linkages required for frequency selection and frequency indication on the megahertz frequency selectors, volume adjustment, squelch adjustment, and function selection. These control circuits do not include fine adjustment trimmers or potentiometers used to obtain optimum performance.

b. AF AMPLIFIER ASSEMBLY (BUFFER). The buffer amplifier assembly provides the wide-band audio and low-level auxiliary guard outputs necessary for secure voice capability.

(1) FUNCTIONAL DESCRIPTION OF AF AMPLIFIER ASSEMBLY (BUFFER). - The af amplifier assembly (buffer) provides amplification of the auxiliary guard and main receiver auxiliary audio signals that are applied to the TSEC/KY-38 security equipment when in the appropriate mode. The detected audio signal from collector of 1A3Q4 is fed to the input of main receiver buffer amplifier 1A9A1. The output of this circuit is present at output connector 1A9J14-N. This output is referred to as the wide-band auxiliary audio output. When the guard receiver of RT- 695A/PRC -41 is receiving a guard signal, output of the guard receiver is applied to the guard receiver buffer amplifier 1A9A2. The guard signal is amplified in this circuit and is present at output connector 1A9J14-S as a low-level auxiliary guard output. Output of the guard receiver is also applied to audio module 1A4 as normal guard audio output.

(2) TEST DATA. - Testing the af amplifier assembly (buffer) involves checking each of the subordinate circuit outputs. The main receiver auxiliary audio output is on pin 1A9J14-N. The low-level auxiliary guard receiver output is on pin 1A9J14-S. Refer to the servicing block diagram (figure 4-19) for signal flow of af amplifier assembly (buffer) section. To determine if the buffer amplifier is operating properly, perform the steps of procedure in table 4-7. The main receiver functional section and guard receiver functional section must be operating properly.

(a) TEST EQUIPMENT REQUIRED.

1. Signal Generator AN/USM-44A
2. Signal Generator Pad CN-315/URM-26
3. Fuse MX- 1730/U
4. Electronic Multimeter TS-505/U

(b) TEST SETUP. - Set RT-695A/PRC-41 on the test bench with case CY-3884/PRC-41 removed, and connect PP-3700/PRC-41 to provide required primary power. Refer to figure 5-21. Connect junction box to KY-38 connector 1A9J14 on front panel of RT-695A/PRC-41.

(c) AF AMPLIFIER ASSEMBLY(BUFFER) FUNCTIONAL SECTION CIRCUIT, TROUBLE ISOLATION. -To determine which circuit is defective, perform the steps of procedure of table 4-7 in sequence. After each preliminary action, compare indications obtained with the expected result in the NORMAL INDICATION column. If the indications are normal, proceed to the next step. If abnormal indications are observed, follow the procedure in the NEXT STEP column. Before performing the steps of table 4-7, set the SQUELCH control on

**TABLE 4-7. AF AMPLIFIER ASSEMBLY (BUFFER) CIRCUITS, TROUBLE ISOLATION**

STEP	TEST POINT	PRELIMINARY ACTION	NORMAL INDICATION	NEXT STEP
1	Number 2 terminal on buffer amplifier 1A9A1 and 1A9A2 in main chassis	Connect multimeter to terminal number 2 of buffer amplifier modules 1A9A1 and 1A9A2.	Measure 26.5 volts dc.	If normal indication is not obtained, check power distribution circuits.
2	MAIN RCVR AUX AUDIO output jack on junction box	Connect AN/USM-44A to antenna connector 1A9J28. Set AN/USM-44A to 304.7 MHz, modulated 30% with 1000 Hz, with a signal output level of 3 microvolts. Set frequency control knobs on front panel of RT-695A/PRC-41 to 304.7 MHz. Connect TS-505/U to MAIN RCVR AUX AUDIO jack on junction box.	Measure at least 0.25 volt ac.	If normal indication in not obtained, replace buffer amplifier module 1A9A1.
3	LOW LEVEL AUX GUARD AUDIO output jack on junction box	Set AN/USM-44A to 243.0 MHz, modulated 30% with 1000 Hz, with a signal output level of 5 microvolts. Connect TS-505/U to LOW LEVEL AUX GUARD AUDIO jack on junction box.	Measure at least 0.15 volt ac.	If normal indication not obtained, replace buffer amplifier module 1A9A2.

RT-695A/PRC-41 to maximum counterclockwise position and OFF-T/R-T/R/G-DIAL LIGHT switch to T/R.

c. MAIN CHASSIS 1A9. - The main chassis of RT-695A/PRC-41 forms a mounting base for eight modular subassemblies and a control panel. The main chassis contains mechanical linkage between the frequency selector knobs on the control panel and tuned circuits of three of these modules. Refer to paragraph 4-6g(1)(a). The modules are secured to the main chassis by captive screws. Electrical interconnection between modules is provided by multipin connectors on the main chassis which mate with the applicable modules. Refer to figure 5-93. The main chassis also contains the receive-transmit switch, mixer circuit, control relays, fuses, cabling, af amplifier assembly (buffer), and filament regulator transistor 1A9Q1. (1) FUNCTIONAL DESCRIPTION.

(a) RECEIVE-TRANSMIT SWITCH. (Refer to figure 4-6.) - The receive-transmit switch is a rotary type coaxial switch having two rotor sections and is located in the main chassis. This switch may be actuated to one position in either direction by rotary relays 1A9L6 and 1A9L7. When the press-to-talk button on Handset H-33E/PT is pressed (equipment placed in transmit operation), relays 1A9K1, 1A9K3, and 1A9K4 become energized. Relay 1A9L6 then becomes energized, since it is grounded through contacts 8 and 10 of switch S1A and is provided 26.5 volts dc through contacts of relay 1A9K1. Relay 1A9L6 causes coaxial switches S1A and S1B to be rotated clockwise one position. At this time, the ground is removed from relay 1A9L6 and it is deenergized. The opposite condition exists when the press-to-talk button is released (equipment placed in receive operation). Releasing the press-to-talk button places 26.5 volts dc on relay 1A9L7 through contacts on relay 1A9K1. Relay 1A9L7 is energized, since it is grounded through contacts 3 and 6 of switch S1A. Relay 1A9L7 causes coaxial switches S1A and S1B to rotate counterclockwise one position. At this time, the ground is removed from relay 1A9L7 and deenergized.

(2) TEST DATA. - Trouble isolation considerations for the main chassis of RT-695A/PRC-41 are concerned with main chassis cabling, detail parts of filtering and voltage regulation circuits, receive-transmit relays, and mechanical linkages. Refer to paragraph 4-6g for information pertaining to control circuits. Trouble isolation of the wiring of the main chassis cable and detail parts involves point-to-point continuity testing by use of figures 5-85 through 5-93. Refer to step 11 of table 4-4, step 5 of table 4-5, and step 8 of table 4-6 for testing procedures of the receive-transmit switch. Check filament regulator 1A9Q1 voltages by use of table 5-12. Mechanical troubles may be located by inspection.

d. PRIMARY POWER CIRCUITS.

(1) FUNCTIONAL DESCRIPTION.

(a) STORAGE BATTERY BB-451/U.

Storage Battery BB-451/U is used to provide

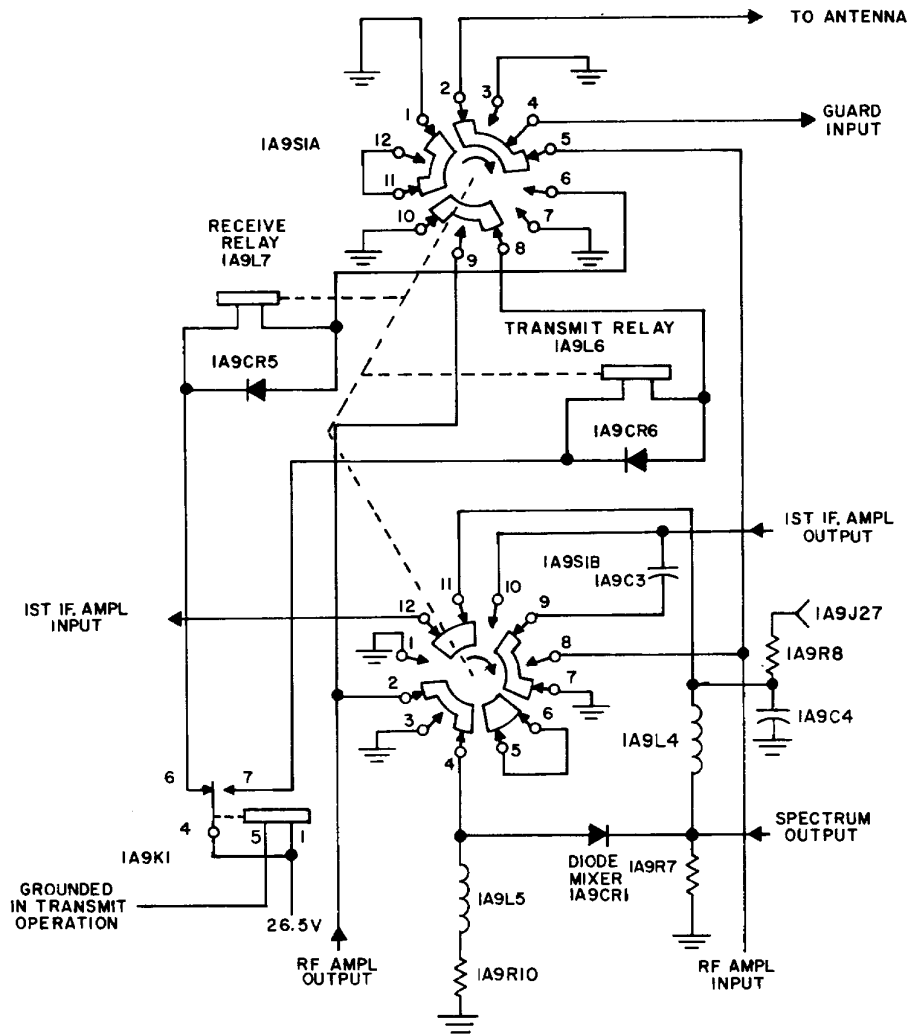

Figure 4-6. Receive-Transmit Switch, Simplified Schematic Diagram

required dc primary supply for RT-695A/PRC-41. The BB-451/U is made up of 16 series-connected cells. Each cell provides 1.86 volts open circuit when fully charged with a capacity of 25 ampere hours (nominal). The BB-451/U may be operated in any altitude without spilling out the electrolyte.

(b) POWER SUPPLY PP-3700/PRC-41. (Refer to figures 4-19 and 5-86.) - Power Supply PP-3700/PRC-41 is used to provide a required 26.5-volt dc primary supply for RT-695A/PRC-41 when a 115- (cables normally connected for 115 volts ac) or 230-volt, 50- to 400-Hz supply is available. The 115 or 230-volt, 50- to 400-Hz primary supply is stepped down to 45 volts by transformer T1, rectified, filtered, and made available to RT-695A/PRC-41 (figure 5-82). With the OFF-T/R-T/R/G-DIAL LIGHT switch on the front panel of RT-695A/PRC-41 in any position except OFF, power is applied through the filter to series regulator Q3. Dc amplifiers Q1 and Q2 supply required filtered base current for series regulator Q3. Diode CR7, in combination with a variable resistor, provides a voltage reference of 28 volts at the base of dc amplifier Q1. An overload protection circuit is provided by diode CR9, overload trip Q4, and voltage reference diode CR8. If the 26.5-volt dc output supply should become shorted and draw

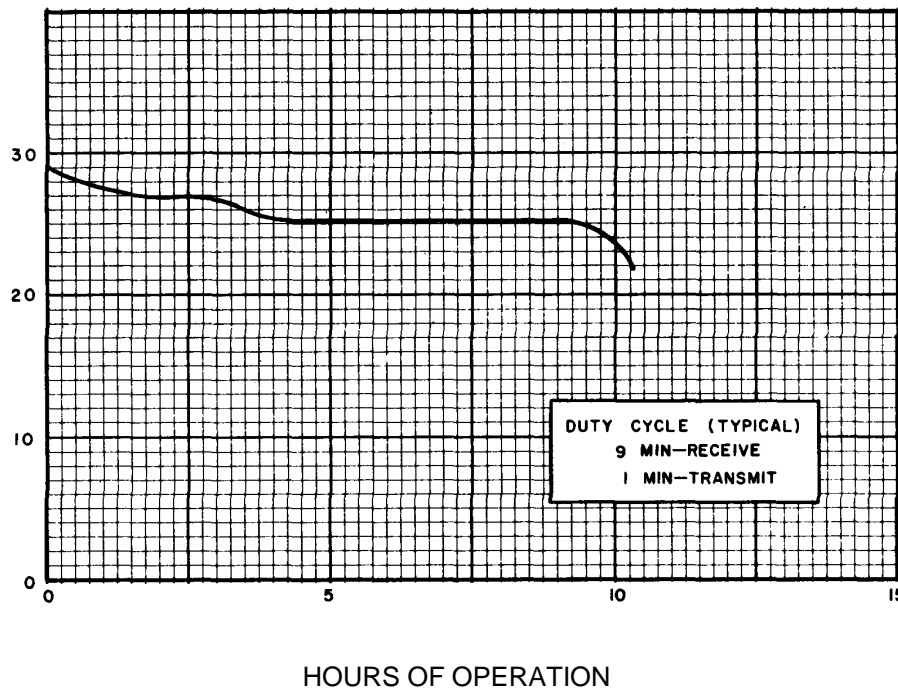

Figure 4-7. Storage Battery BB-451/U, Typical Rate of Discharge

excessive current, voltage at the emitter of series regulator Q3 is caused to drop below the reference level of 15 volts dc set by zener diode CR8. This permits voltage reference diode CR9 and overload trip Q4 to conduct sufficiently to lower the reference voltage at the base of dc amplifier Q1, which prevents conduction of dc amplifiers Q1 and Q2 and series regulator Q3. The dc amplifiers and series regulator will remain turned off even though the higher load may be removed. The output circuit is held open until the OFF-T/R-T/R/G-DIAL LIGHT switch is set to OFF position for at least 5 seconds and then returned to one of the other positions of this control.

(2) STORAGE BATTERY BB-451/U, TEST DATA. - Trouble isolation considerations for Storage Battery BB-451/U are concerned with its ability to provide the required dc voltage for operation of RT-695A/PRC-41. Normal procedure for checking the level of charge of a battery is by measuring the terminal voltage developed across a very high load resistance. This procedure provides very little indication when applied to BB-451/U because of the characteristics of charge and discharge (figure 4-7). Instructions for battery use and a log for recording battery charges are printed on the inside of the battery cover.

(3) POWER SUPPLY PP-3700/PRC-41, TEST DATA. - Trouble isolation considerations for Power Supply PP-3700/PRC-41 are concerned with the ability of the power supply to provide the required 26.5 volts for operation of RT-695A/PRC-41. If PP-3700/PRC-41 does not provide the required 26.5-volt dc supply, connect it into the test setup described in paragraph 4-6d(3)(b), and perform the trouble isolation procedures of table 4-7.

(a) TEST EQUIPMENT REQUIRED. Multimeter AN/PSM-4C and a power resistor are required for trouble isolation procedures.

(b) TEST SETUP. - Set Power Supply PP-3700/PRC-41 on the test bench with the side which clamps to the rear of RT-695A/PRC-41 upward. Loosen two captive screws in top plate, and remove main chassis from the dust cover. Connect Power Electric Cable Assembly CX-8687/PRC-41 between ac power connector on PP-3700/PRC-41 dust cover and a 115-volt, 50- to 400-Hz primary power source. Refer to figure 4-8.

(c) POWER SUPPLY PP-3700/PRC-41, CIRCUIT TROUBLE ISOLATION. - To determine which circuit or circuit group is defective, perform the steps of procedure of table 4-8 in the sequence listed. After each preliminary action, compare the indications obtained with expected results in the NORMAL INDICATION column. If indications are normal, proceed to the next step. If abnormal indications are observed, follow procedures outlined in the NEXT STEP column.

e. POWER DISTRIBUTION CIRCUITS.

(1) FUNCTIONAL DESCRIPTION. (Refer to figure 4-9.) - Power distribution circuits are the

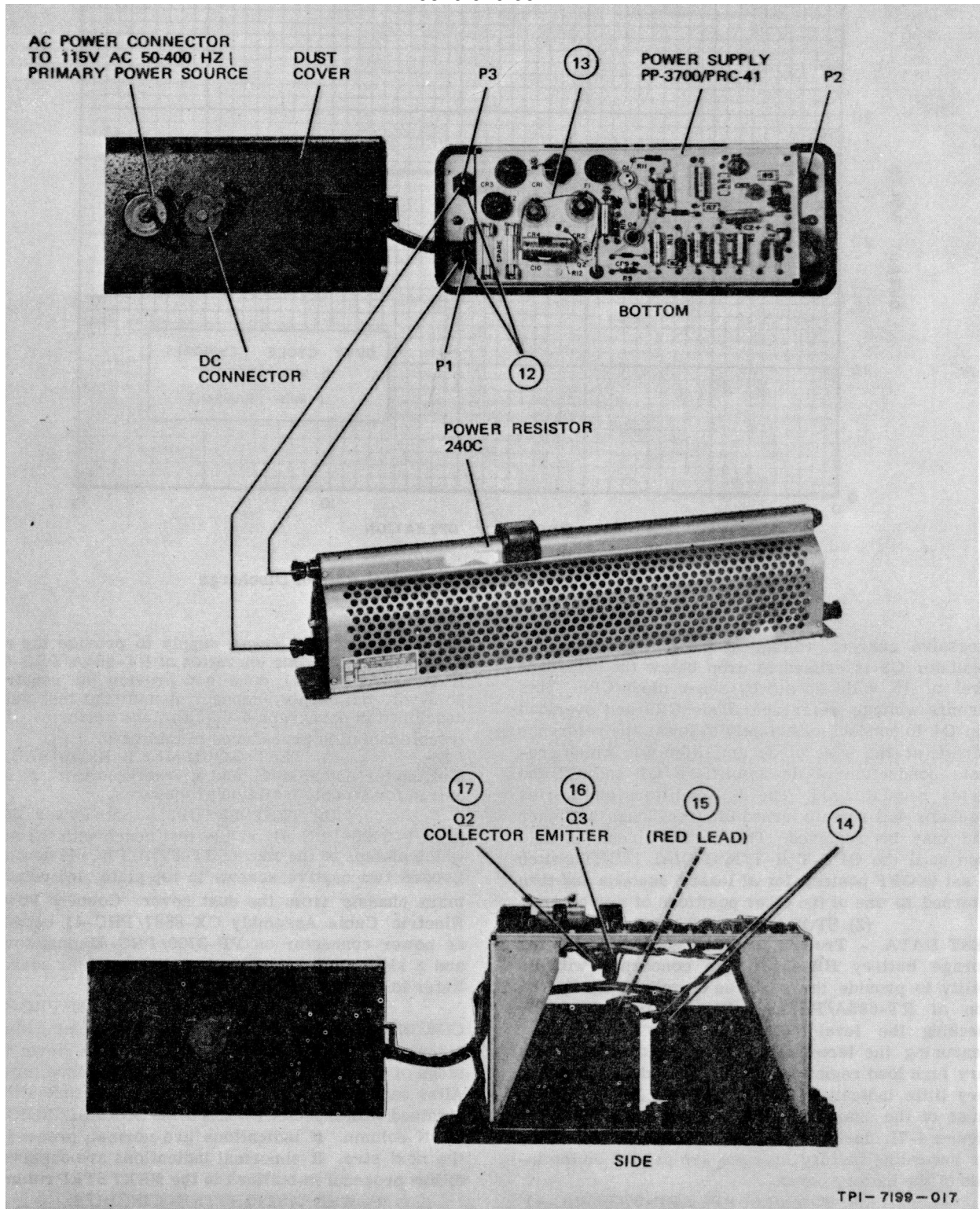

Figure 4-8. Power Supply PP-3700/PRC-41, Test Setup

TABLE 4-8. POWER SUPPLY PP-3700/PRC-41. TROUBLE ISOLATION

STEP	TEST POINT	PRELIMINARY ACTION	NORMAL INDICATION	NEXT STEP
1	12 Wiring side of plugs P1 and P3 (figure 4-8)	Connect a jumper between P3 and P2. Adjust power resistor for 8 ohms, and connect it between P1 and P3. Connect AN/PSM-4C to test point 12 to P1, and negative lead to P3.	Measure 26.5 volts dc.	If output voltage is not 26.5 volts dc but is less than 30 volts dc and greater than 24 volts dc, adjust variable resistor R6 for 26.5-volt dc output. If output cannot be adjusted to 26.5 volts dc, proceed to step 4. If output voltage is zero, proceed to step 2. Proceed to step 3.
2	Visual	Remove ac input power to PP-3700/PRC-41. Check fuses F1 and F2.	Fuses F1 and F2 check normal.	
3	14 Terminals 5 and 6 of power transformer T1 (figure 4-8)	Connect AN/PSM-4C from terminal number 5 of transformer T1 to ground and from terminal number 6 to ground.	Measure 45 $\pm$ 3 volts dc .	If indication is abnormal, check transformer T1.
4	13 Refer to figure 4-8	Connect AN/PSM-4C between test point 13 and ground.	Measure 41 $\pm$ 3 volts dc.	If voltage is zero, check diodes CR1 through CR4 and capacitor C10.
5	15 Red lead on inductor L1	Connect AN/PSM-4C between test point 15 and ground.	Measure 41 $\pm$ 3 volts dc.	If normal indication is not obtained, remove jumper wire from P3 momentarily, reconnect it to P3, and listen for relay K1 to click. If relay K1 does not click, check relay K1. If relay K1 clicks, check inductor L1 and capacitor C1.
6	16 Refer to figure 4-8	Connect AN/PSM-4C between test point and 16 and ground.	Measure 27 $\pm$ 3 volts dc	If normal indication is not obtained, measure voltages on transistors Q1, Q2, and Q4 given in table 5-13. Isolate defective component by indication of voltage measurements and checking associated circuits.
7	12 Plug P3 (figure 4-8)	Connect AN/PSM-4C between 12 test point ground.	Measure 27 $\pm$ 2 volts	If normal indication is not obtained , measure voltage on transistor Q3 given in table 5-13. Transistor Q3 is mounted in heat sink in dust cover. Check cabling between chassis and transistor Q3.

**TABLE 4-8. (Continued)**

STEP	TEST POINT	PRELIMINARY ACTION	NORMAL INDICATION	NEXT STEP
8	12  Refer to figure 4-8	Connect AN/PSM-4C to test point 12, positive lead to P3, and negative lead to P1. Connect jumper from P1 to P3 momentarily, then remove jumper.	Measure 26.5 volts dc before connecting jumper, 0 volt dc after shorting P1 to P3.	If normal indications are not obtained, measure voltages on transistors Q1, Q2, Q3, and Q4 given in table 5-14. Isolate defective component by indication of voltage measurements and checking associated circuits. Voltage at test point 12 should return to 26.5 volts dc by disconnecting jumper from P2 to P3, waiting 5 seconds then reconnecting jumper from P2 to P3.

switching and circuits which provide required power for operation of the circuits and detail parts or Radio Receiver-Transmitter RT-695A/PRC-41. Primary 26.5 volts dc for operating RT-695A/PRC-41 is applied through electrical contacts of Receiver-Transmitter Case CY-3884/PRC-41 to the main chassis of RT695A/PRC-41. This primary power may be supplied by Storage Battery BB-451/U, Power Supply PP3700/PRC-41, or by an aircraft or vehicular power source. The 26.5-volt dc primary supply is used to provide power for the 180- and -6.8 volts dc supplies in the dc power supply module, to energize relays for receive-transmit switching, and for filament and transistor voltages.

(a) DC POWER SUPPLY MODULE 1A1. (See figure 5-85.) - When the OFF-T/R-T/R/G-DIAL LIGHT switch is placed in T/R position, the 26.5-volt dc primary supply is applied to terminal 4 of transformer 1A1T1 and the collectors of both switching transistors 1A1Q1 and 1A1Q2 of the dc power supply module. Since no two transistors are exactly alike, either Q1 or Q2 will begin to conduct because of positive biasing of the bases of Q1 and Q2. Assuming Q1 begins to conduct first, current flows through that section of the primary winding of transformer T1 between terminals 3 and 4. As the field about winding 3-4 expands, an induced voltage is developed across the secondary 8-9 and the base feedback windings 1-2 and 6-7. Transistor Q1 continues to conduct until the core of transformer T1 becomes saturated. At saturation, the base voltage of Q1 goes to zero and Q1 stops conduction. The magnetic field about the primary winding of 1-2 and 3-4 begins to collapse, and Q2 is switched on and begins to conduct. Switching transistor Q2 continues to conduct until it has saturated the core of transformer T1, and then Q1 is switched on again. Transistors Q1 and Q2 provide an 800-Hz output to bridge rectifiers CR1 through CR4. Inductor L1 and capacitors C1, C2, and C3 form a low-pass filter. Resistor R5 is a bleeder resistor for the filtered output. Zener diode CR5 is connected between ground and the B-supply and provides the -6.8-volt dc output. The B+ supply is 180 volts dc and is made available to modulator, spectrum generator, and rf and power amplifier modules.

(b) FILAMENT CIRCUITS. - The vacuum tubes requiring filament voltage are contained in spectrum generator and rf and power amplifier modules. Refer to figure 4-10. These filaments are connected in series parallel. All tubes require 6.3 volts for filament operation. Resistors 1A9R2, 1A9R3, 1A9R6, and 1A9R8 are voltage equalizing resistors. Transistor 1A9Q1 is a filament voltage regulator.



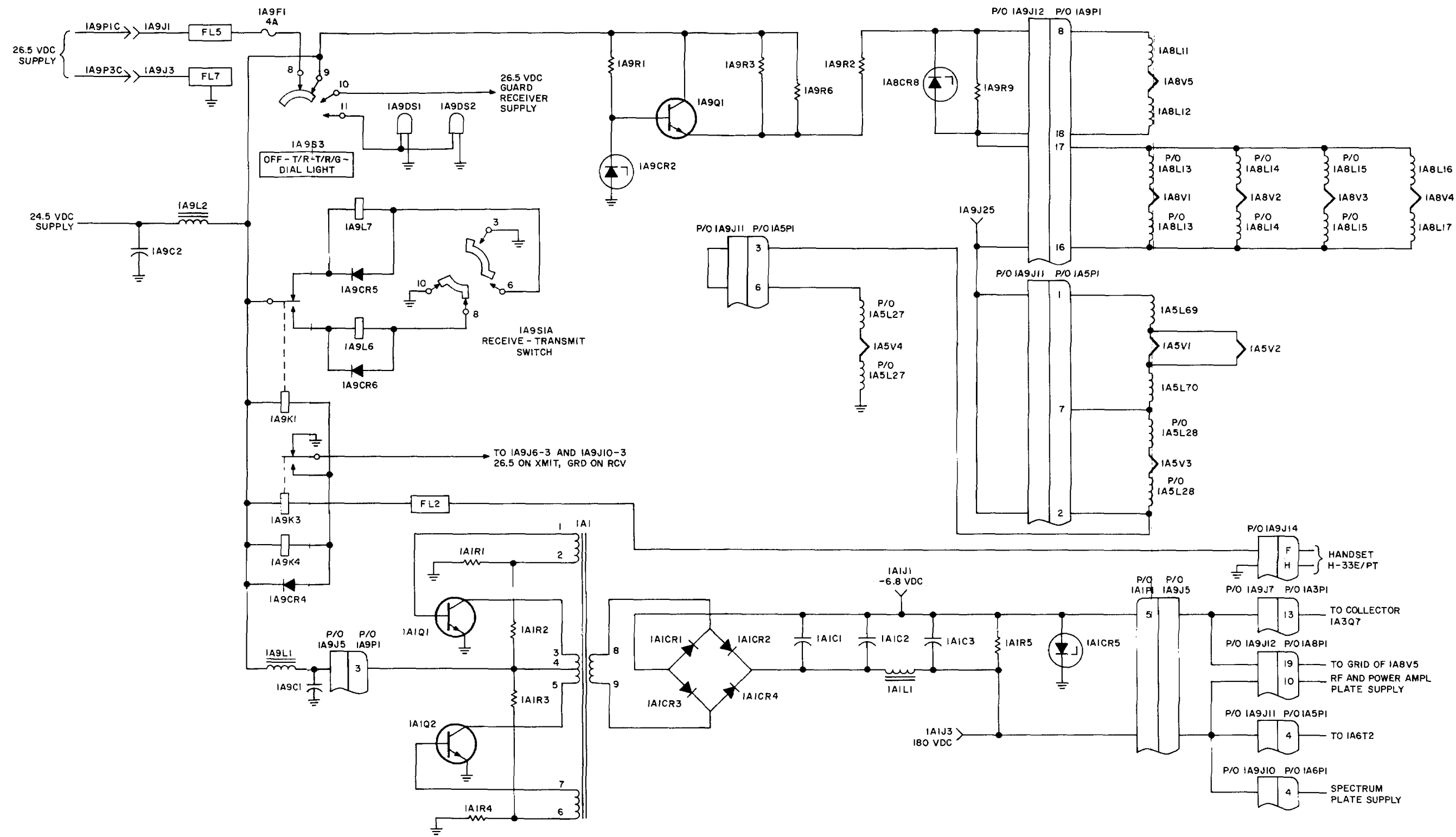

Figure 4-9. Radio Receiver-Transmitter RT-695A/PRC-41, Power Distribution, Simplified Schematic Diagram  
ORIGINAL 4-37, 4-38

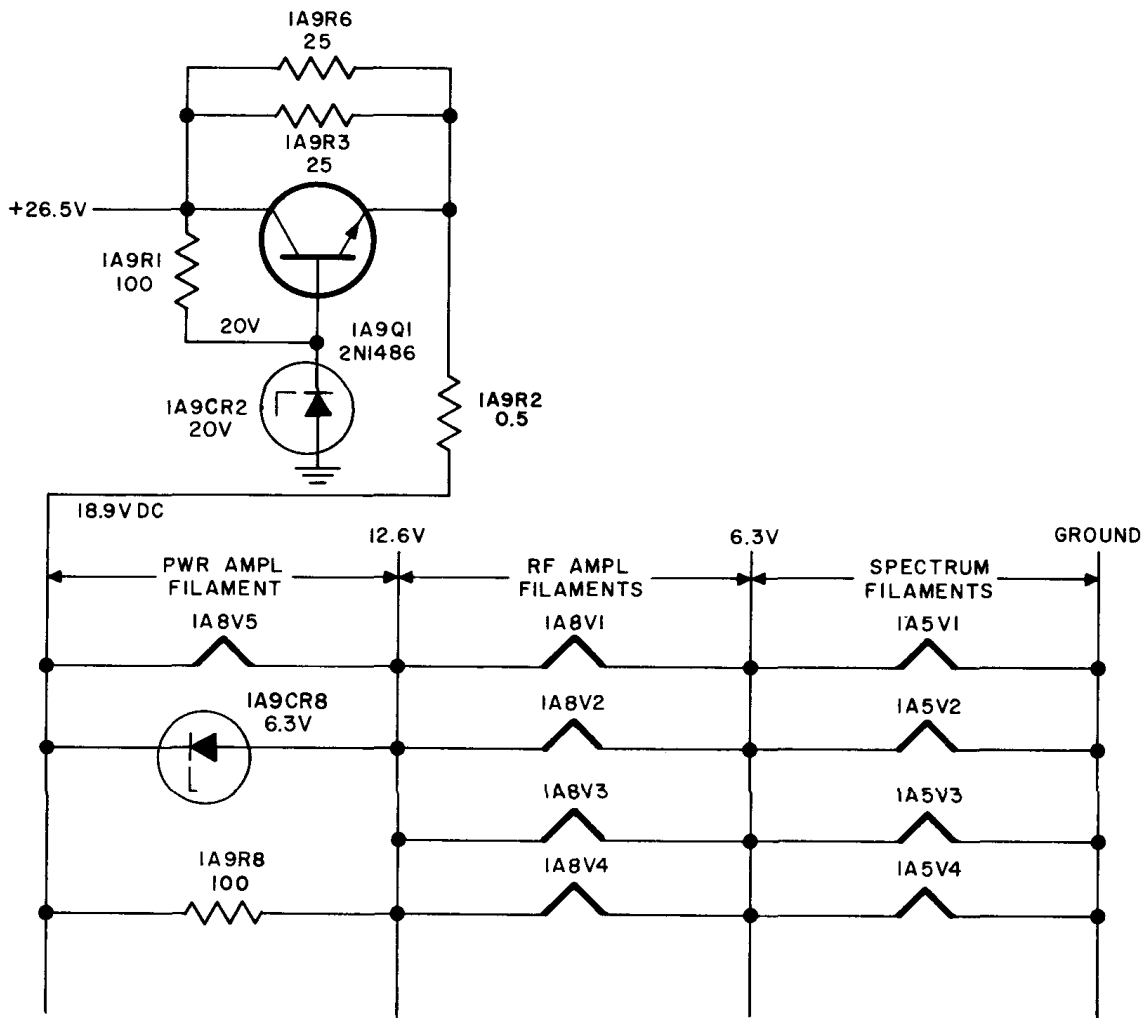

Figure 4-10. Radio Receiver-Transmitter RT-695A/PRC-41, Filament Circuits

(c) RECEIVE-TRANSMIT RELAYS, DIAL LIGHT, AND GUARD RECEIVE MODULE. The 26.5-volt dc primary supply is available to receive-transmit relays, dial lights, and transistor stages of the guard receiver module. Refer to paragraphs 4-6g(1)(b) and 4-6g(1)(c) for a description of power distribution and operation of receiver-transmit relays. Dial lights are lit when OFF-T/R-T/R/G DIAL LIGHT switch is in the DIAL LIGHT position for lighting the front panel frequency indicator of RT-695A/PRC-41. When OFF-T/R-T/R/G-DIAL LIGHT switch is placed in T/R/G position, 26.5-volt dc primary supply is applied to the collector and base of guard receiver voltage regulator 1A7Q14. The emitter of voltage regulator Q14 provides a regulated supply for transistor stages of the guard receiver module.

(2) TEST DATA. - If the power distribution circuits are suspected or known to be defective, perform the steps of procedure of table 4-9 to isolate the trouble to a defective circuit or circuit group. Refer to the servicing block diagram, figure 4-19, for location of test points.

(a) TEST EQUIPMENT REQUIRED. Test equipment required consists of Electronic Multimeter TS-505/U.

(b) TEST SETUP. - Set RT-695A/ PRC-41 on the test bench with CY-3884/PRC-41 removed. To provide required power, connect PP3700/PRC-41 to the RT-695A/PRC-41 (figure 5-21). Set OFF-T/R-T/R/G-DIAL LIGHT switch to T/R position. Connect Handset H-33E/PT to connector 1A9J13 on front panel of RT-695A/PRC-41.

**TABLE 4-9. POWER DISTRIBUTION CIRCUITS, TROUBLE ISOLATION**

STEP	TEST POINT	PRELIMINARY ACTION	NORMAL INDICATION	NEXT STEP
1	Fuse 1A9F1 on rear of RT-695A/PRC-41 main chassis	Connect Electronic Multimeter TS-505/U from fuse test jack to ground.	Measure 26.5 volts dc.	If normal indication is not obtained, check PP-3700/PRC-41 and fuse 1A9F1.
2	Collector of 1A9Q1	Connect TS-505/U from collector of 1A9Q1 to ground.	Measure 26.5 volts dc.	If normal indication is not obtained, check fuse 1A9F1 and OFF-T/R-T/R/G/ DIAL LIGHT switch 1A9S3.
3	Emitter of 1A9Q1	Connect TS-505/U from emitter of 1A9Q1 to ground.	Measure 18.9 volts dc.	If normal indication is not obtained, check voltage at base of transistor 1A9Q1 (measure 20 volts dc).
4	21 See test jack 1A9J25.	Connect TS-505/U from 1A9J25 to ground	Measure 6.3 volts dc.	If normal indication is not obtained, measure tube filaments in spectrum generator and rf and power amplifier module for continuity (measure approximately 4 ohms).
5	Test jack 1A1J2	Connect TS-505/U from 1A1J2 to ground.	Measure 26.5 volts dc.	If normal indication is not obtained, remove dc power supply module, and check continuity between pin 3 of 1A9J5 and fuse test jack 1A9F1.
6	Test jack 1A1J3	Set TS-505/U to 250-volt dc range, and connect it from 1A1J3 to ground.	Measure 180 volts dc.	If normal indication is not obtained, check transistors Q1 and Q2, bridge rectifiers CR1 through CR4, and associated circuits of dc power supply module.
7	Test jack 1A1J1	Set TS-505/U to 50-volt dc range, and connect it from 1A1J1 to ground.	Measure -6.8 volts dc.	If normal indication is not obtained, check zener diode 1A1CR5.
8	18 Refer to figure 4-1	Connect TS-505/U from junction of capacitor 1A9C2 and inductor 1A9L2	Measure 26.5 volts dc.	If normal indication is not obtained, check continuity of inductor 1A9L2.
9	Pin 9 of connector 1A9J8	Remove audio module. Connect TS-505/U from pin 9 of 1A9J8 to ground.	Measure 24.5 volts dc.	If normal indication is not obtained, measure continuity between pin 9 of 1A9J8 and 1A9J2.

**TABLE 4-9. (Continued)**

STEP	TEST POINT	PRELIMINARY ACTION	NORMAL INDICATION	NEXT STEP
10	Pins 5 and 11 of connector 1A9J7	Replace audio module, and remove 3 <sup>rd</sup> if and squelch module. Connect TS-505/U in turn from 1A9J7 to pin 5 to ground and pin 11 to ground.	Measure 24.5 volts dc.	If normal indication is not obtained, measure continuity from pin 5 1A9J7 to 1A9L2. Check relay 1A9K3. If normal indication is not obtained, check relay 1A9K3.
11	Pin 3 connector 1A9J6	Replace 3 <sup>rd</sup> if and squelch module. Set frequency selector knobs to 299.9 MHz. Remove 1 <sup>st</sup> and 2 <sup>nd</sup> if amplifier module. Press press-to-talk button on H-33E/PT. Connect TS-505/U from pin 3 of 1A9J6 to ground.	Measure 26.5 volts dc.	
12	Pin 6 of connector 1A9J6	Unkey press-to-talk button on H-33E/PT. Connect TS-505/U from pin 6 of 1A9J6 to ground.	Measure 24.5 volts dc.	If normal indication is not obtained, measure continuity between pin 6 of 1A9J6 and 1A9L2.
13	Pin 3 of connector 1A9J9	Replace 1 <sup>st</sup> and 2 <sup>nd</sup> if amplifier module, and remove guard receiver module. Connect TS-505/U from pin 3 of 1A9J9 to ground. Set OFF-T/R-T/R/G-DIAL LIGHT switch to T/R/G.	Measure 26.5 volts dc.	If normal indication is not obtained, check function switch 1A9S3 and relay 1A9K4.
14	Pin 3 of connector 1A9J10	Replace guard receiver module, and remove modulator module. Connect TS-505/U from pin 3 of 1A9J10 to ground. Press press-to-talk button on H-33E/PT.	Measure 26.5 volts dc.	If normal indication is not obtained, measure continuity between pin 3 of 1A9J10 to 1A9L2. Check relay 1A9K3.
15	Pin 8 of connector 1A9J10	Connect TS-505/U from pin 8 of 1A9J10 to ground.	Measure 24.5 volts dc.	If normal indication is not obtained, measure continuity between pin 8 of 1A9J10 to 1A9J10. Check relay 1A9K3.
16	Pin 20 of connector 1A9J12	Unkey press-to-talk button on H-33E/PT. Replace modulator module. Remove rf and power amplifier module. Connect TS-505/U from pin 20 of 1A9J12 to ground.	Measure 24.5 volts dc.	If normal indication is not obtained, measure continuity between pin 20 of 1A9J12 and 1A9L2.

(c) POWER DISTRIBUTION CIRCUIT, TROUBLE ISOLATION. - To determine which circuit or circuit group of the power distribution circuits is defective, perform the steps of procedure of table 4-9 in the sequence listed. After each preliminary action, compare indications obtained with expected results in the NORMAL INDICATION column. If indications are normal, proceed to the next step. If abnormal indications are observed, follow procedures outlined in the NEXT STEP column.

f. FREQUENCY GENERATOR CIRCUITS. - The frequency generator circuits are composed of circuits of the spectrum generator module and high- and low- frequency oscillator stages in the 1st and 2nd if amplifier module. These circuits provide required frequency injection for both the main receiver and transmitter functional sections. The following frequency generation discussion is applicable to that required for frequency conversion and carrier development of the main receiver and transmitter functional sections of Radio Receiver-Transmitter RT-695A/PRC-41. Refer to paragraph 4-4a for a discussion of frequency generation for the guard receiver functional section.

(1) FUNCTIONAL DESCRIPTION, RECEIVE OPERATION. - Three injection frequency signals for RT-695A/PRC-41 are obtained from three crystal controlled oscillators. The first injection signal, 200 to 370 MHz, is obtained from the spectrum generator module, while the second, 17.1- to 26.1-MHz, and third, 2.9- to 3.8-MHz, injection signals are obtained from high- and low-frequency oscillator stages in the 1st and 2nd if amplifier module. Figure 4-11 lists the three injection frequencies for each frequency in the operating range of RT-695A/PRC-41. In receive operation, signals in the 225.0 to 399.9-MHz range are mixed with appropriate spectrum generator module output frequency in the range of 200 to 370 MHz to produce the 20- to 29.9 MHz first if frequency. The first intermediate frequency is then mixed with the appropriate high- frequency oscillator output in the range of 17.1 to 26.1 MHz to provide the second intermediate frequency in the 2.9- to 3.8-MHz range. The second intermediate frequencies are then mixed with the appropriate low-frequency oscillator output in the range of 2.9 to 3.8 MHz to provide the third intermediate frequency of 500 kHz.

(2) FUNCTIONAL DESCRIPTION, TRANSMIT OPERATION. - In transmit operation, the appropriate low- and high- frequency oscillator crystal frequencies are mixed in transmitter mixer 1A2Q4 of 1st and 2nd if amplifier module to produce the intermediate frequencies in the range of 20.0 to 29.9 MHz. This intermediate frequency is then mixed in diode mixer 1A9CR1 with the appropriate spectrum generator module output frequency to produce an output signal in the 225.0- to 399.9-MHz range.

(3) IF FREQUENCY CALCULATION. - The following procedure may be used to find the three injection frequencies from the final transmit or receive operation frequency. Refer to figure 4-11.

Example: 294.6 MHz Subtract 20.0 MHz from the operating frequency. For this example. 20 from 294.6 gives  

$$\begin{array}{r} 294.6 \text{ MHz} \\ -20.0 \text{ MHz} \\ \hline 274.6 \text{ MHz} \\ 270.0 \text{ MHz} \end{array}$$
 274.6. The first two digits of this number (10-MHz digits) with an added 0 gives 270MHz, which is the spectrum generator module injection frequency.

294.6 MHz To determine the 17.1- to 26.1-MHz oscillator frequency, add 17.1 to the unit digit. In  

$$\begin{array}{r} 294.6 \text{ MHz} \\ 4.0 \\ \hline +17.0 \\ \hline 21.1 \text{ MHz} \end{array}$$
 this case  $4 + 17.1 = 21.1$  MHz, which is the high-frequency oscillator injection .frequency.

294.6 MHz In transmit operation, the low-frequency oscillator frequency can be determined by adding 2.9  

$$\begin{array}{r} 294.6 \text{ MHz} \\ 0.6 \text{ MHz} \\ \hline +2.9 \\ \hline 3.5 \text{ MHz} \end{array}$$
 MHz to the 10th megahertz digit. In this case,  $0.6 + 2.9 = 3.5$  MHz which is the low-frequency oscillator injection frequency.

In receive operation, the low-frequency oscillator is shifted +500 kHz from the predetermined transmit frequency. Since the oscillator frequency varies from 2.9 to 3.6 MHz, this frequency can be determined from the transmit oscillator frequency. If it is 3.4 MHz or greater, subtract 500 kHz. If it is 3.3 MHz or less, add 500 kHz.

Example: 294.6 MHz 
$$\begin{array}{r} 294.6 \text{ MHz} \\ 0.6 \\ \hline +2.9 \\ \hline 3.5 \text{ MHz Transmit} \\ \text{frequency} \end{array}$$

$$\begin{array}{r} 294.2 \text{ MHz} \\ 0.3 \\ \hline +2.9 \\ \hline 3.1 \text{ MHz} \end{array}$$

$$\begin{array}{r} -500 \text{ kHz} \\ 3.0 \text{ MHz Receive} \\ \text{frequency} \end{array}$$

$$\begin{array}{r} +.500 \text{ kHz} \\ 3.6 \text{ MHz} \end{array}$$

(a) SPECTRUM GENERATOR MODULE. (Refer to figure 5-89.) - The spectrum generator module supplies an injection signal of 200 to 370 MHz in 10-megahertz steps to the receiver first mixer or the transmitter second

mixer (diode mixer 1A9CR1). The spectrum generator module consists of a crystal oscillator followed by a multiplier and a 2-stage rf amplifier. The crystal oscillator is a series mode crystal oscillator with 1 of 18 crystals in the cathode circuit of V1. The crystals are opened on the fifth mode. Both the crystal and the plate tank circuit of V1, which is tuned to the crystal frequency, are switched to obtain the desired frequency. Capacitor C6 is the capacity portion of the plate tank.

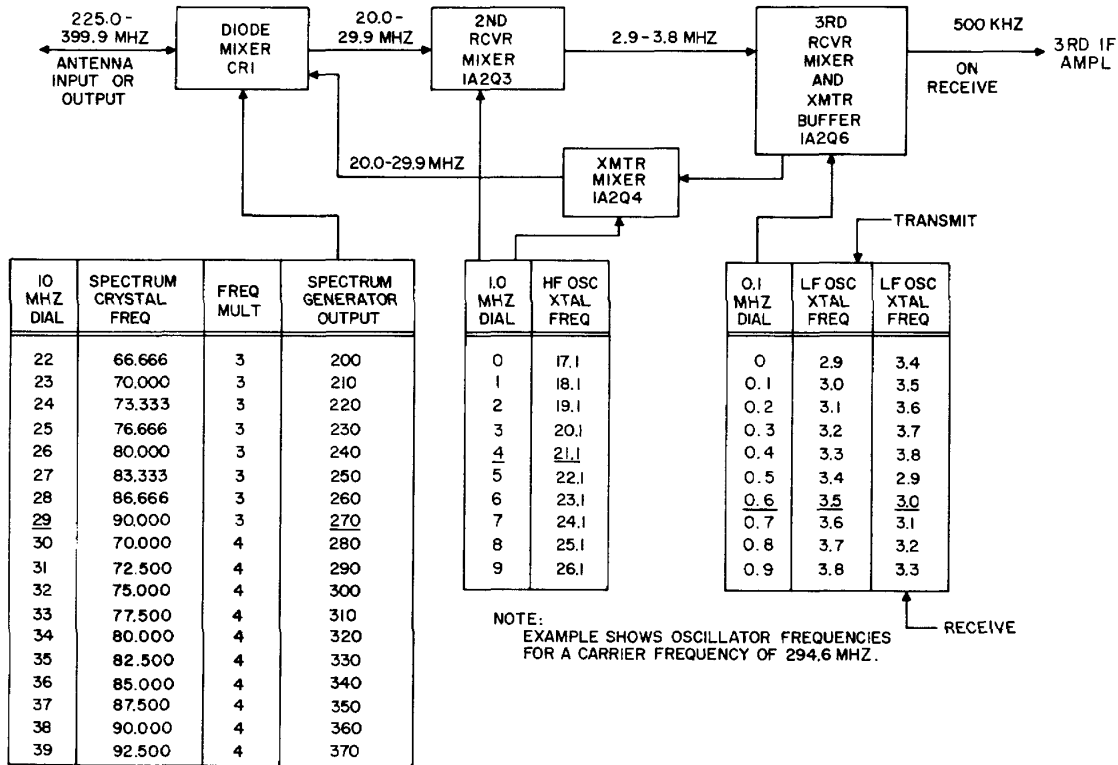

Figure 4-11. Main Receiver and Transmitter, Functional Section, Frequency Scheme

Choke coil L19 tunes out crystal reactance as different crystals are selected. Tuned circuit Z1 and capacitor C10, in plate circuit of V2, is tuned to triple or quadruple the oscillator frequency for output frequencies from 200 to 370 MHz. This signal is fed to two grounded-grid amplifiers, V3 and V4. The plate circuits of V3 and V4 are tuned with plate tank circuits identical to the plate tank circuit of V2. When a new frequency is selected, both the inductance and capacitance of tuned circuits Z1, Z2, and Z3 are varied to obtain the proper resonant frequency. The output is fed to mixer 1A9CR1 in the main chassis.

(b) HIGH-FREQUENCY OSCILLATOR 1A2Q5. - High-frequency oscillator 1A2Q5 is located in the 1st and 2nd if amplifier module. This 17.1-to 26.1-MHz oscillator is a feedback type oscillator employing series-mode crystals. The oscillator output is switched from second receiver mixer 1A2Q3 to transmitter mixer 1A2Q4 by energizing relay 1A2K2. The undesired harmonics of high-frequency oscillator Q5 are attenuated by a low-pass filter composed of R28 inductors L26 through L29 and the input capacitance of the respective mixers.

(c) LOW-FREQUENCY OSCILLATOR 1A2Q7. -Low-frequency oscillator 1A2Q7 is located in the 1st and 2nd if amplifier module and is similar to a Colpitts vacuum tube oscillator. Switch S3 switches 2.9- to 3.8-MHz crystals in transmit operation, and with the aid of relay 1A2K3, changes crystal frequency by  $\pm 500$  kHz for receive operation. With 1A2K3 in the receive position, low-frequency oscillator

1A2Q7 frequency is +500 kHz from the second intermediate center frequency. With 1A2K3 in the transmit position (energized), the low-frequency oscillator and second intermediate frequencies are identical. Relay 1A2K3 also grounds the low-frequency oscillator receive crystal in this position. The low frequency oscillator signal is fed through transistor 1A2Q6, which acts as a buffer amplifier for the low-frequency oscillator in transmit operation, to transmitter mixer 1A2Q4.

(4) TEST DATA. - Trouble isolation considerations for the frequency generation circuits are concerned with their ability to provide the required frequency injection for receive and transmit operations of RT-695A/PRC-41. If trouble is known or suspected as being caused by a defective frequency generation circuit, connect RT-695A/PRC-41 into the test setup described in paragraph 4-6f(4)(b), and perform the trouble isolation procedures of table 4-10. Refer to figure 4-1 and the servicing block diagram (figure 4-19) for location of test points and signal flow of the frequency generation circuits.

(a) TEST EQUIPMENT REQUIRED. - Test equipment required consists of Electronic Multimeter TS-505/U.

(b) TEST SETUP. - Set RT-695A/PRC-41 on the test bench with CY-3884/PRC-41 removed, and connect PP-3700/PRC-41 to provide required primary power. Refer to figure 5-21. Set frequency selector knobs on front panel of RT-695A/PRC-41 to 399.9 MHz. Set OFF-T/R-T/R/G-DIAL LIGHT switch to T/R.

(c) FREQUENCY GENERATION CIRCUIT, TROUBLE ISOLATION. - To determine which frequency generation circuit and which detail part of the generation circuit is defective, perform the steps of procedure of table 4-10 in the sequence listed. After each preliminary action, compare indications obtained with expected result in the NORMAL INDICATION column. If indications are normal, proceed to the next step. If abnormal indications are observed, follow procedures outlined in the NEXT STEP column. Frequency generation circuits are located in the spectrum generator module (200- to 370-MHz output), and the 1st and 2nd if amplifier module (high-frequency oscillator 1A2Q5, 17.1- to 26.1-MHz output, and low-frequency oscillator 1A2Q5, 2.9- to 3.8-MHz output).

g. CONTROL CIRCUITS.

(1) FUNCTIONAL DESCRIPTION. - The control circuits are composed of the controls on the front panel of Radio Receiver-Transmitter RT-695A/PRC-41, and circuits and mechanical linkages between front panel and the controlled module or circuit. Table 3-1 of Operator's Section of Installation and Operation Technical Manual for Radio Set AN/PRC-41A, NavShips 0967-872-5010, lists and describes the controls of RT-695A/PRC-41. The control circuits include application of primary power; selection of either transmit/receive, transmit/receive/guard, or transmit/receive/guard and dial light operation; control of receiver output level; setting of main receiver squelch level; and frequency selection. The three frequency selector knobs on the front panel of RT-695A/PRC-41 are mechanically linked to the tuned circuits of rf and power amplifier, 1st and 2nd if amplifier, and spectrum generator modules. Rotation of any of the three frequency selector knobs adjusts the applicable tuned circuits of these modules to the frequency which is indicated by the MHz frequency indicator window on the front panel of RT-695A/PRC-41. The control (VOL) volume permits adjustment of the audio output level of both the main and guard receivers. The SQUELCH control provides an adjustment which will permit main receiver audio output only when a signal is present at the input of the receiver.

(a) MECHANICAL FREQUENCY SELECTION. (Refer to figure 4-12.) - The selection of a desired frequency within the range of 225.0 to 399.9 MHz is provided by three control knobs on the control panel and is indicated by the frequency dial reading in the MHz frequency indicator window. Assume the MHz frequency indicator window shows 225.0 MHz. If the 10-MHz knob (located on the left of the control panel) is rotated one detent position clockwise, the MHz frequency indicator window would show 235.0 MHz. If the 1-MHz knob (located in the center of the control panel) is rotated one detent position clockwise, the MHz frequency indicator window would show 236.0 MHz. If the 0.1-MHz knob (located on the right side of the control panel) is rotated one detent position clockwise, the MHz frequency window would show 236.1 MHz. A change of one detent position of the 10-MHz knob causes the coupler that drives the rf and power amplifier module to be rotated through 10 degrees and the coupler that drives the spectrum generator module to be rotated through 20 degrees. A change of one detent position of the 1-MHz knob causes the coupler that drives the rf and power amplifier module to be rotated through 1 degree; the coupler that selects crystals and oscillator coils for the high-frequency oscillator of 1st and 2nd if amplifier module to be rotated through 30 degrees; and the coupler that adjusts the high-frequency slug rack on 1st and 2nd if amplifier module to be rotated through 30 degrees. A change of one detent position of the 0.1-MHz knob causes the coupler that drives the low-frequency slug rack and selects crystal for low-frequency oscillator of the 1st and 2nd if amplifier module to be rotated through 30 degrees; the coupler that drives the high-frequency slug rack to be rotated through 3 degrees; and the coupler that drives the rf and power amplifier module to be rotated through 0.1 degree. In this way, the electrical circuits of the RT-695A/PRC-41 may be adjusted to select any desired frequency in the range of 225.0 to 399.9 MHz.

(b) RECEIVE OPERATIONAL SWITCHING. -Figure 4-13 shows Radio Receiver-Transmitter RT-695A/PRC-41 in receive operation. With the OFF-T/R-T/R/G-DIAL LIGHT switch changed from OFF to any of the other positions, the 26.5-volt dc primary power is applied to the circuits of

**TABLE 4-10. FREQUENCY GENERATION CIRCUIT TROUBLE ISOLATION**

STEP	TEST POINT	PRELIMINARY ACTION	NORMAL INDICATION	NEXT STEP
1	3 Test jack 1A2J2 on 1 <sup>st</sup> and 2 <sup>nd</sup> if amplifier module	Connect Electronic Multimeter TS-505/U between test jack 1A2J2 and ground.	Measure -2.5 to -4.0 volts dc.	If indication is not obtained, proceed to step 2.
2	Same as step 1	Same as step 1 except rotate the 10 <sup>th</sup> MHz frequency selector knob from .9 through .0.	Same as step 1.	If indication is not obtained, check those low-frequency crystal circuits associated with selector knob setting, and measure voltages of transistor 1A2Q7 (table 5-3).
3	4 Test jack 1A2J1 on 1 <sup>st</sup> and 2 <sup>nd</sup> if amplifier module	Connect TS-505/U between test jack 1A2J1 and ground.	Measure -0.5 to -1.5 volt dc.	If indication is not obtained, proceed to step 4.
4	Same as step 3	Same as step 3 except rotate 1-MHz frequency selector knob from 9. to 0..	Same as step 3.	If normal indication is not obtained, check those high-frequency crystal circuits associated with frequency selector knob setting, and measure voltages of transistor 1A2Q5 (table 5-3).
5	19 Test jack 1A5J1 on spectrum generator module.	Connect TS-505/U between test jack 1A5J1 and ground.	Measure -5 to -20 volts dc.	If normal indication is not obtained, proceed to step 6.
6	Same as step 5	Same as step 5, but rotate hundreds-tens frequency selector knob from 39 to 22.	Same as step 5.	If normal indication is not obtained, check those spectrum crystal circuits as associated with frequency selector knob setting, and measure voltages of oscillator 1A5V1 (table 5-6).
7	5 Test jack 1A5J2 on spectrum generator module	Connect TS-505/U between test jack 1A5J2 and ground. Set function switch to T/R.	Measure -1.5 to -5 volts dc.	If normal indication is not obtained, make voltage and resistance checks of multiplier 1A5V2, and of amplifiers 1A5V3 and 1A5V4 (tables 5-6 and 5-7) to aid in location of defective detail.



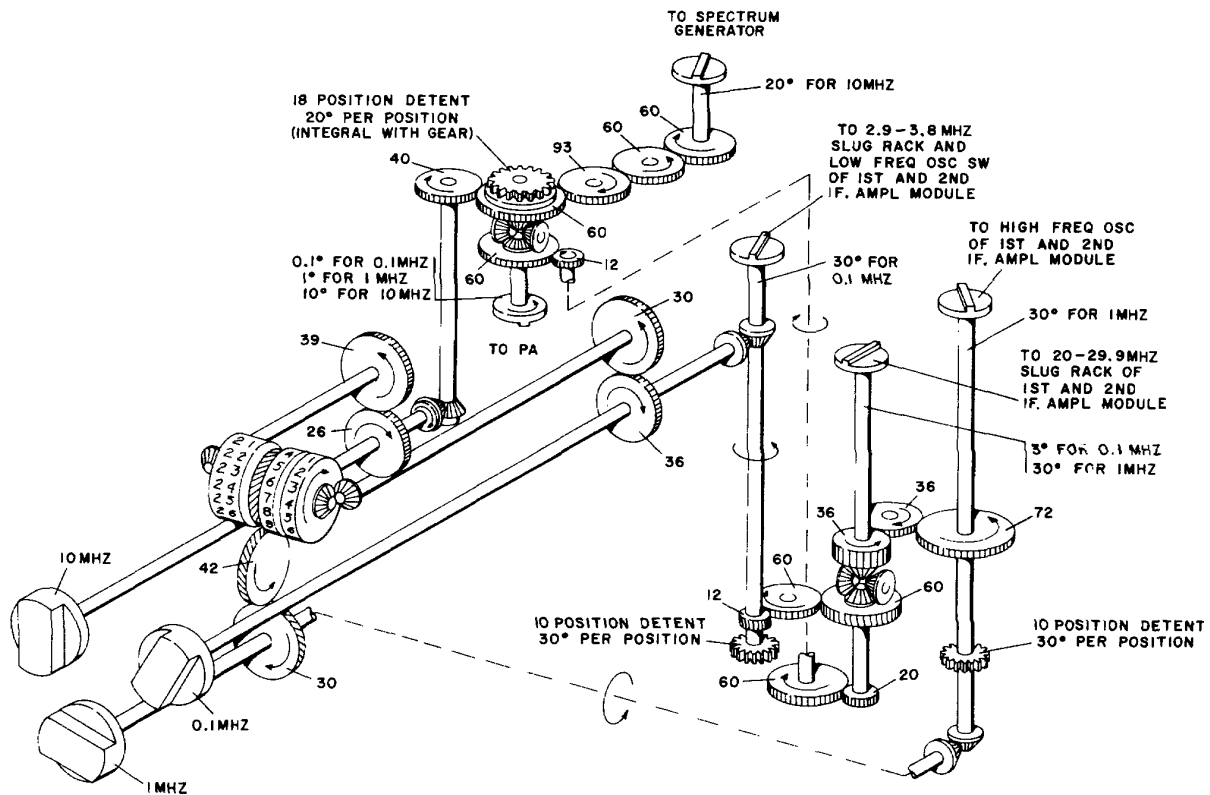

Figure 4-12. Frequency Selection, Functional Diagram

RT-695A/PRC-41. In receive operation (press-to-talk button on H-33E/PT not depressed), signals in the 225.0- to 299.9-MHz range are received at the antenna, coupled through switch contacts 2 and 5 of receive-transmit switch 1A9S1A, and applied to the input of the rf and power amplifier module. The output signal from rf and power amplifier module is coupled through contacts 2 and 4 of receive-transmit switch 1A9S1B to diode mixer 1A9CR1 where it is mixed with the spectrum generator module output signal. The frequency difference between the spectrum generator signal and the received signal is fed through contacts 11 and 12 of receive-transmit switch 1A9S1B to contacts of deenergized relay 1A2K1, and to the input of 20- to 29.9-MHz if amplifiers of 1st and 2nd if amplifier module. In the 1st and 2nd if amplifier module, the resulting signal is further mixed with the output of the low and high-frequency oscillators to produce the final intermediate frequency. The output of 1st and 2nd if amplifier module is coupled to the input of 3rd if and squelch module, where it is detected and fed through contacts of deenergized relay 1A9K4 to the audio module input. The output of the audio module is coupled to H-33E/PT and to pin J of K4-38 connector 1A9J14. When squelch relay 1A3K1 is energized, pin K of 1A9J13 is grounded for automatic relay operation.

(c) TRANSMIT OPERATIONAL SWITCHING. - Figure 4-14 shows Radio Receiver-Transmitter RT-695A/PRC-41 in transmit operation.

Depressing press-to-talk button on the H-33E/PT provides a ground for relays in the main chassis (relays 1A9K1, 1A9K3, and 1A9K4). Energizing relay 1A9K1 causes relay 1A9L6 of the receive-transmit switch to be energized and rotates the receive-transmit coaxial switch to the transmit position. Contacts of relay 1A9K1 ground the collector of transistor 1A9K1 in rf and power amplifier module. Contacts of relay 1A9K3 remove the filtered 24.5-volt dc supply from the receive circuits, apply it to the transmit circuits, and apply 26.5 volts dc to the modulator module and to the relays of 1st and 2nd if amplifier module. Contacts of relay 1A9K4 break the audio output connection from the 3rd if and squelch module to the audio module, apply side-tone from modulator module to the audio module, and remove 26.5-volt dc supply from the guard receiver module. Contacts of energized relay K3 in the 1st and 2nd if amplifier module connect the transmit rotor of crystal switch S3 to the low- frequency oscillator and ground the receive crystal. Contacts of energized relay K2 of 1st and 2nd if amplifier module inject the signal from high- frequency oscillator into the transmitter mixer and ground the base of Q3. The sum of these two oscillator output frequencies, in the 20- to 29.9-MHz range, is fed through contacts of energized relay K1 of 1st and 2<sup>nd</sup> if amplifier module to the 20- to 29.9-MHz if amplifiers. The output of the 20- to 29.9-MHz if amplifiers is fed through contacts 10 and 11 of receive-transmit switch 1A9S1B to diode mixer 1A9CR1. The 20- to 29.9-MHz if signals are mixed with spectrum generator module output signals in the diode mixer to produce output signals in the 225- to 399.9 MHz range. The output from diode mixer 1A9CR1 is fed through contacts 4 and 8 of receive-transmit switch 1A9S1B to the input of rf and power amplifier module. Output from the rf and power amplifier module is fed through contacts 9 and 2 of receive-transmit switch 1A9S1 to the antenna for radiation.

(2) CONTROL CIRCUITS TROUBLE ISOLATION. - Troubleshooting considerations for the control circuits of Radio Receiver-Transmitter RT-695A/PRC-41 are concerned with the ability of the operating controls to control the functional sections and circuits of RT-695A/PRC-41. Since control is very closely related to the particular functional section which is in operation, no special test is provided. Tests for the control circuits are covered as part of the test data of the respective functional sections or circuits. The inability of any one of the control circuits to function properly is an indication of control malfunction. Further troubleshooting of these circuits may be effected through visual inspection and continuity testing.

h. OMNIDIRECTIONAL AND DIRECTIONAL ANTENNAS. - Radio Receiver-Transmitter RT-695A/ PRC-41 may utilize either Antenna AS-1405/PRC-41, directional, or Antenna AS-1404/PRC-41, omnidirectional,(AS-1404/PRC-41 and AS-1405/PRC-41 should each indicate an open circuit).

(1) ANTENNA AS-1405/PRC-41. - Antenna AS-1405/PRC-41 is used with RT-695A/PRC-41 for reception and transmission of signals in the 225.0- to 399.9-MHz range without electrical or physical adjustments, other than extending the elements which are normally collapsed for storage. This antenna is a planar log periodic dipole array which provides unidirectional directivity characteristics. The nominal input impedance is 50 ohms. The azimuthal plane voltage patterns are shown in figure 4-15 for several frequencies in the range. The voltage standing-wave ratio for frequencies between 220 and 400 MHz is shown in figure 4-16. AS-1405/PRC-41 is operated on Mast AB-777/PRC-41.

(2) ANTENNA AS- 1404/PRC -41. - Antenna AS-1404/PRC-41 is used with RT-695A/PRC-41 for reception and transmission of signals in the 225.0- to 399.9-MHz range without electrical or physical adjustments. The AS-1404/PRC-41 has a nominal input impedance of 50 ohms. The azimuthal plane voltage pat-terns are shown in figure 4-17forseveralfrequencies in the range. These patterns apply when AS-1404/ PRC-41 is mounted and operated on RT-695A/PRC-41. The voltage standing-wave ratios for frequencies between 220 and 400 MHz are shown in figure 4-18 when the AS-1404/PRC-41 is mounted and operated on the RT-695A/PRC-41. When AS-1404/PRC-41 is operated on Mast AB-777/PRC-41, the voltage standing-wave ratio properties and the voltage patterns are approximately the same as when operated on RT-695A/PRC -41.

#### 4-7. HISTORY OF MODIFICATIONS.

Effective the date of this manual, there have been no modifications to Radio Set AN/PRC-41A.

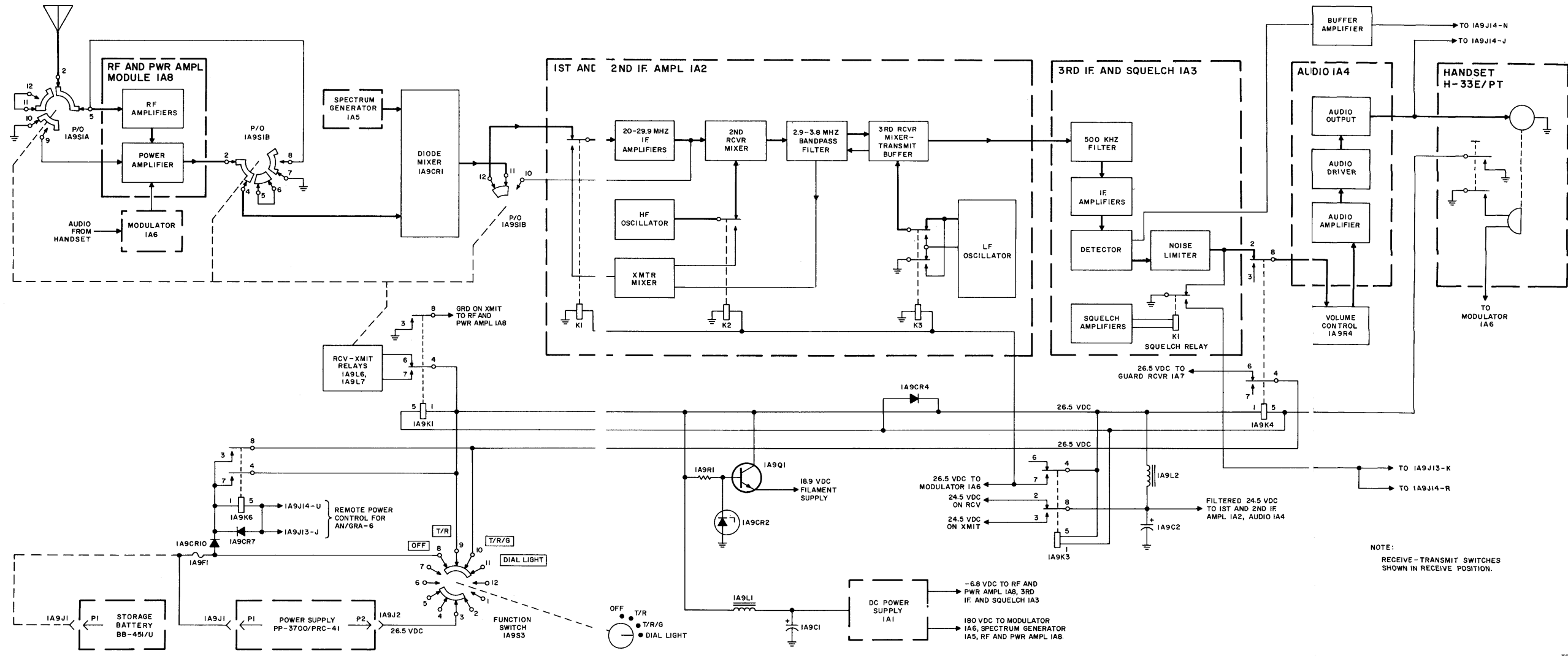

Figure 4-13. Radio Receiver-Transmitter TR-695A/PRC-41, Receiver, Functional Switching Diagram

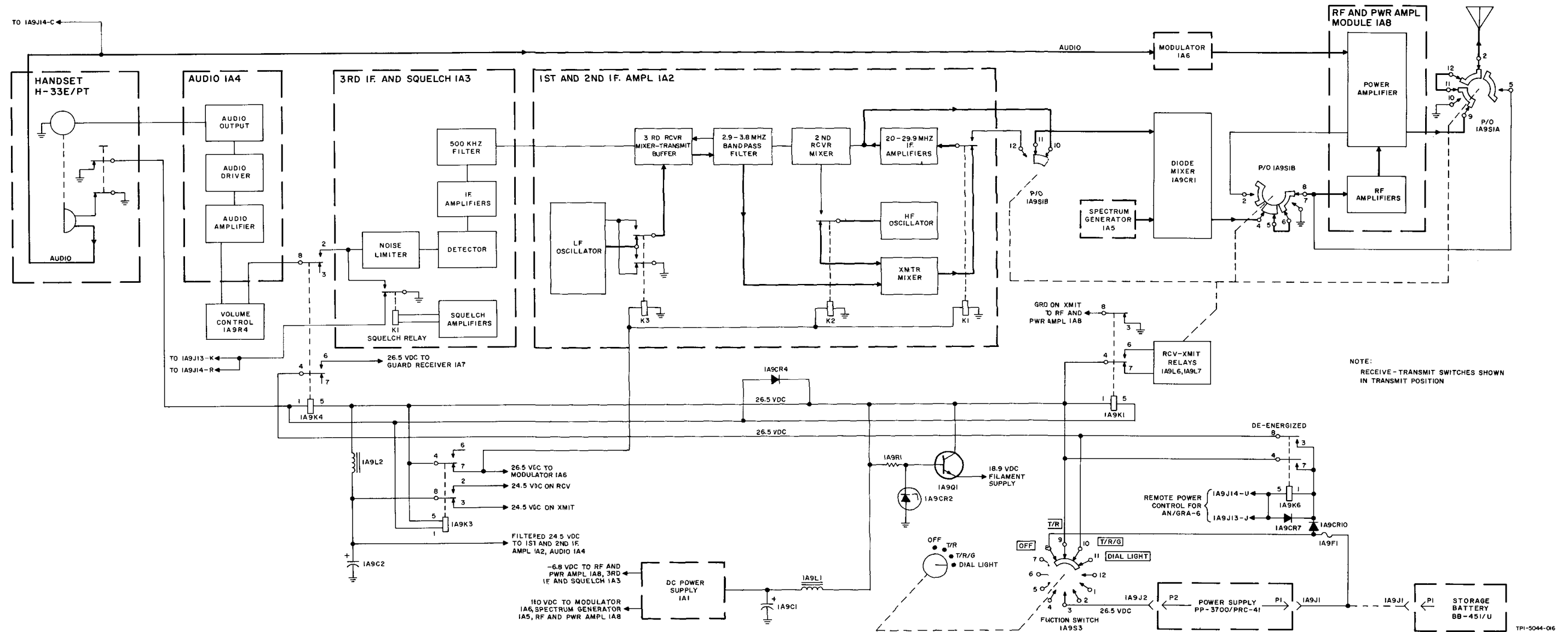

Figure 4-14. Radio Receiver-Transmitter RT-695A/PRC-41, Transmitter, Functional Switching Diagram

ORIGINAL

4-51, 4-52

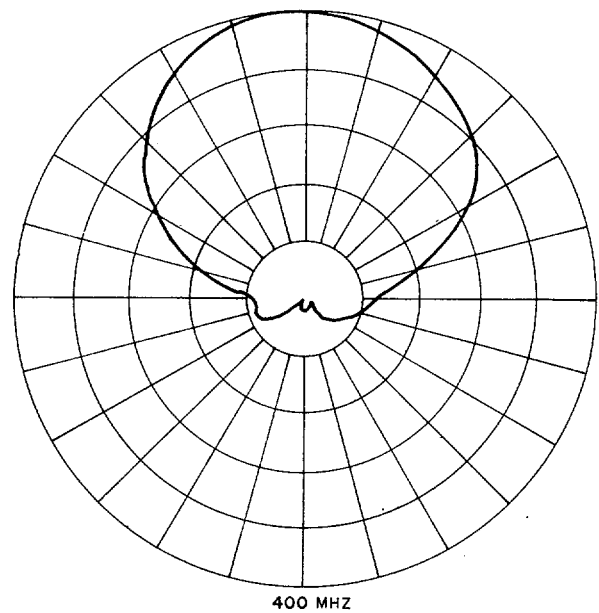
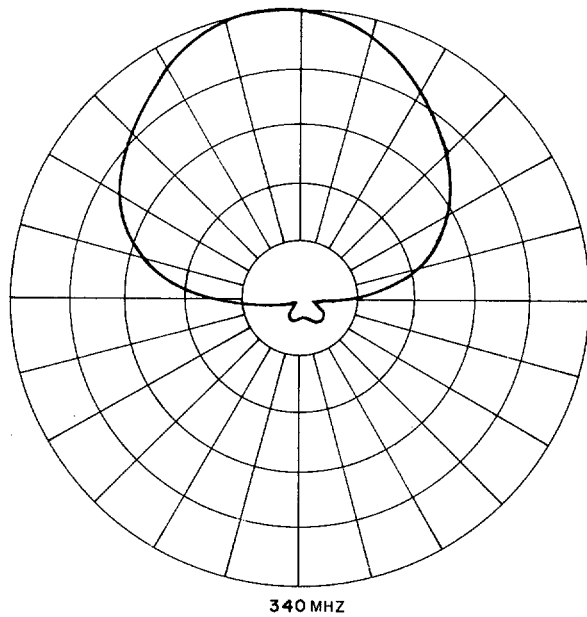
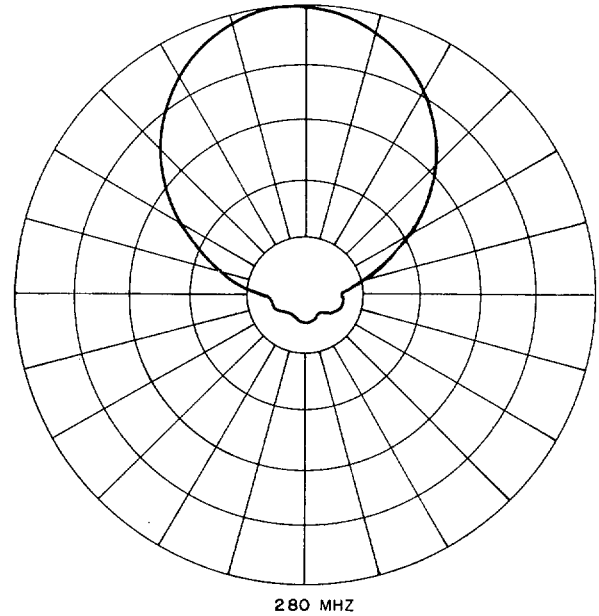
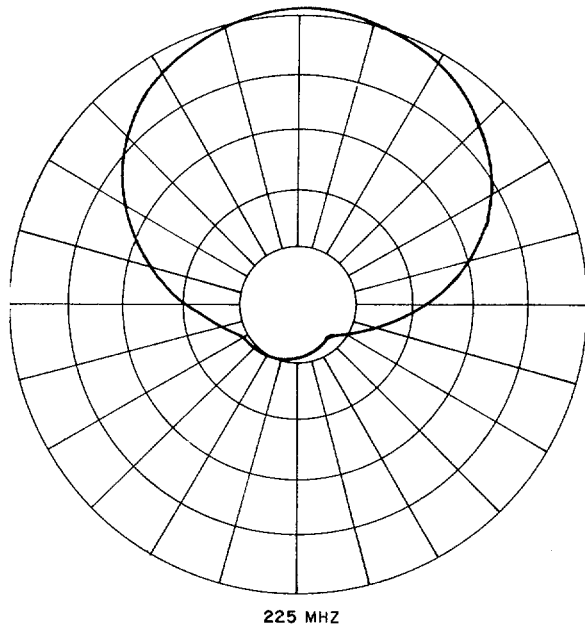

Figure 4-15. Antenna AS-1405/PRC-41, Azimuthal Plane Voltage Pattern

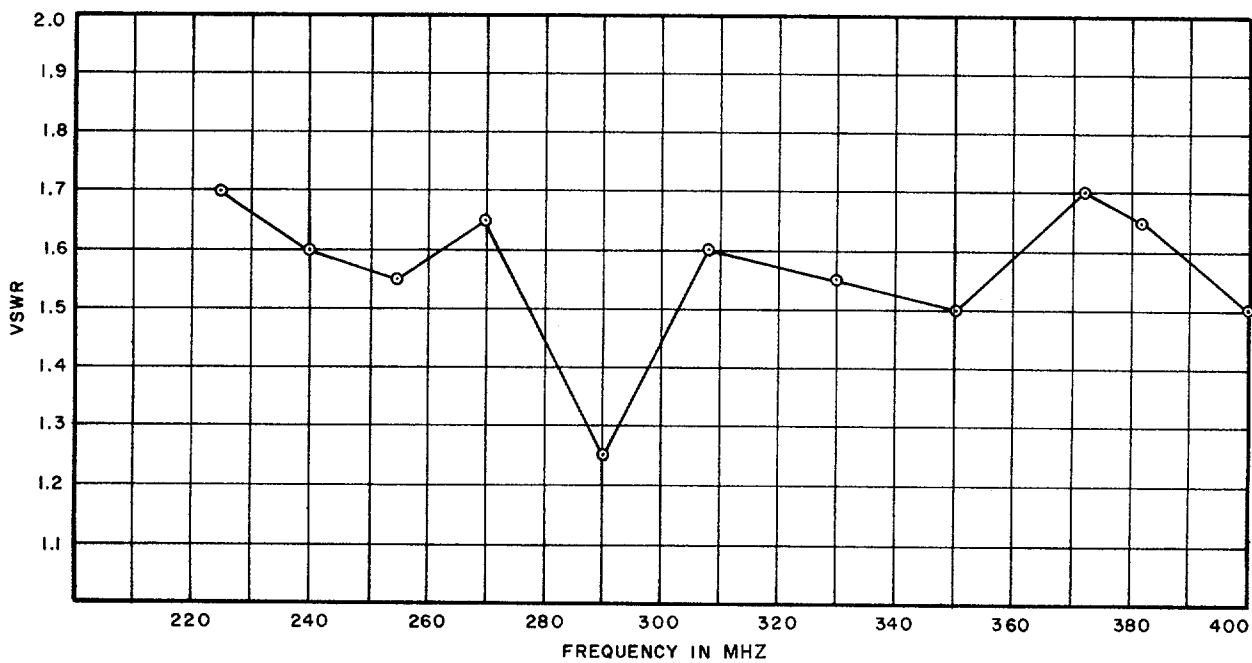

Figure 4-16. Antenna AS-1405/PRC-41, Voltage Standing Wave Ratio

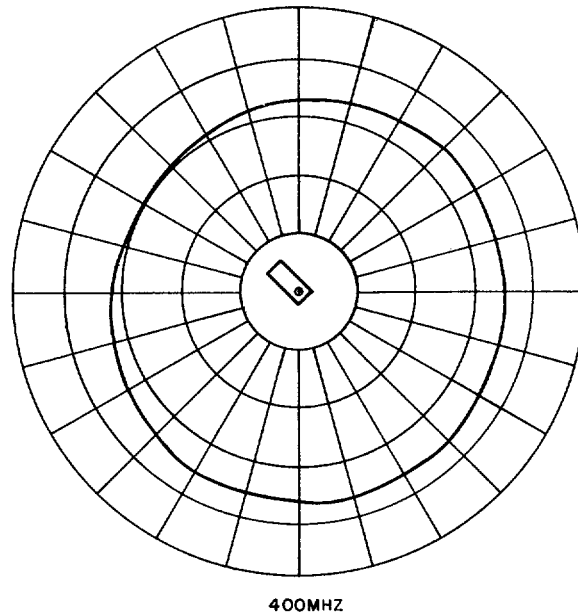
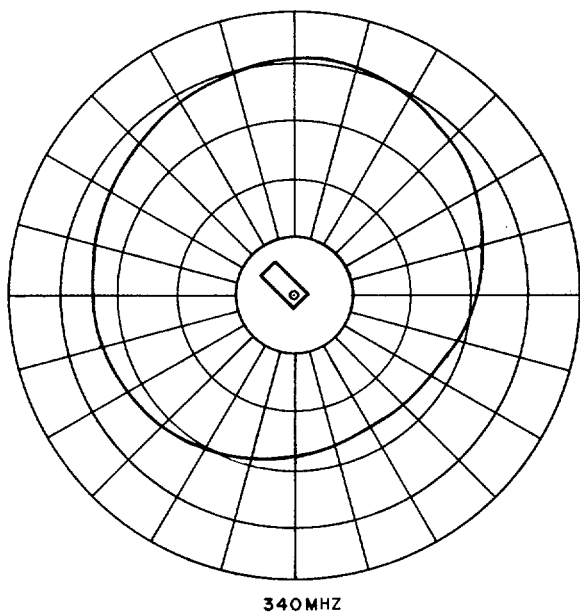
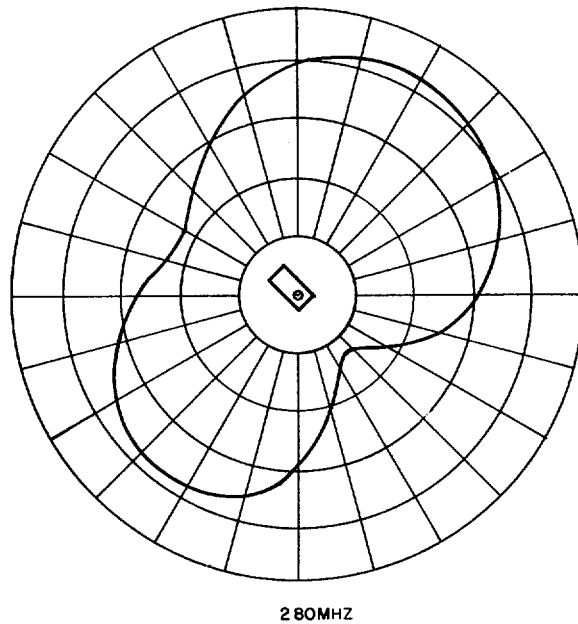
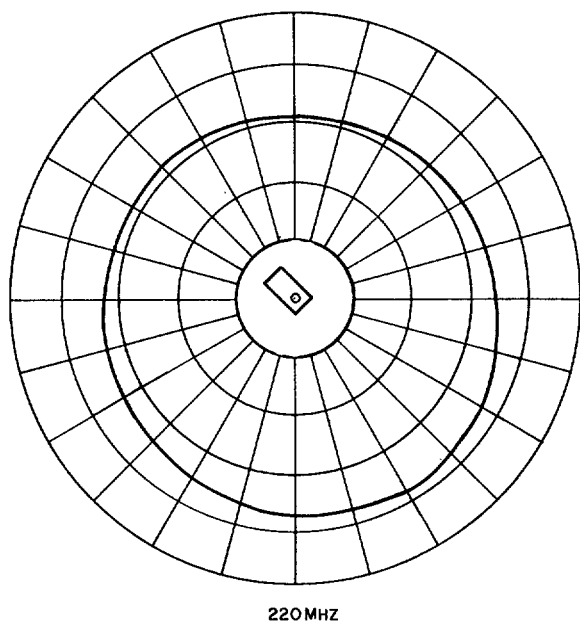

Figure 4-17. Antenna AS-1404/PRC-41, Azimuthal Voltage Pattern

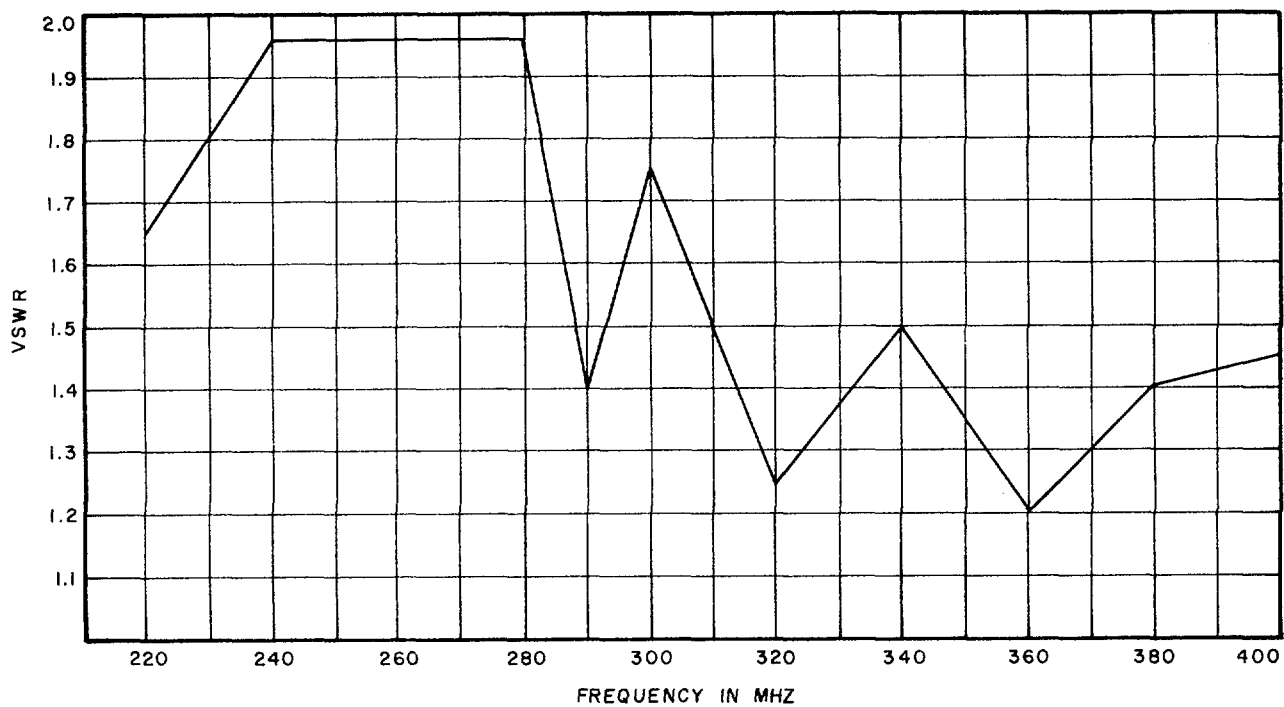

Figure 4-18. Antenna AS-1404/PRC-41, Voltage Standing-Wave Ratio



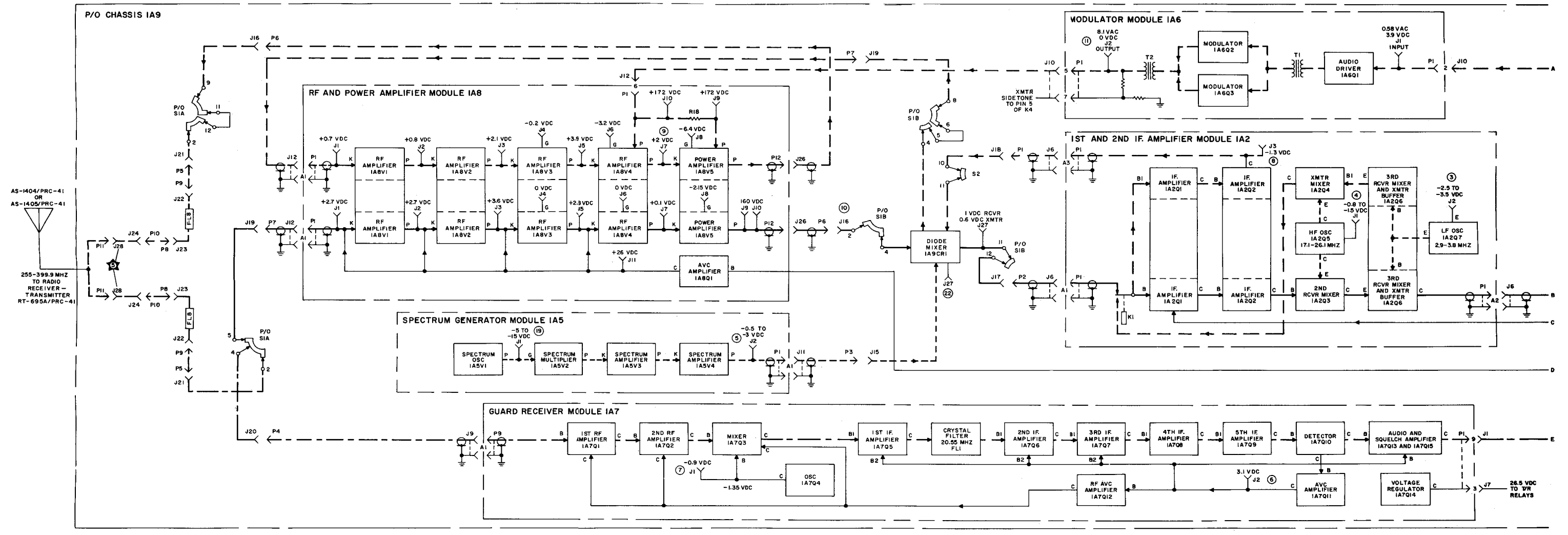

Figure 4-19. Radio Set AN/PRC-41A, Functional Section Servicing Block Diagram (Sheet 1 of 2)

Original

4-57, 4-58

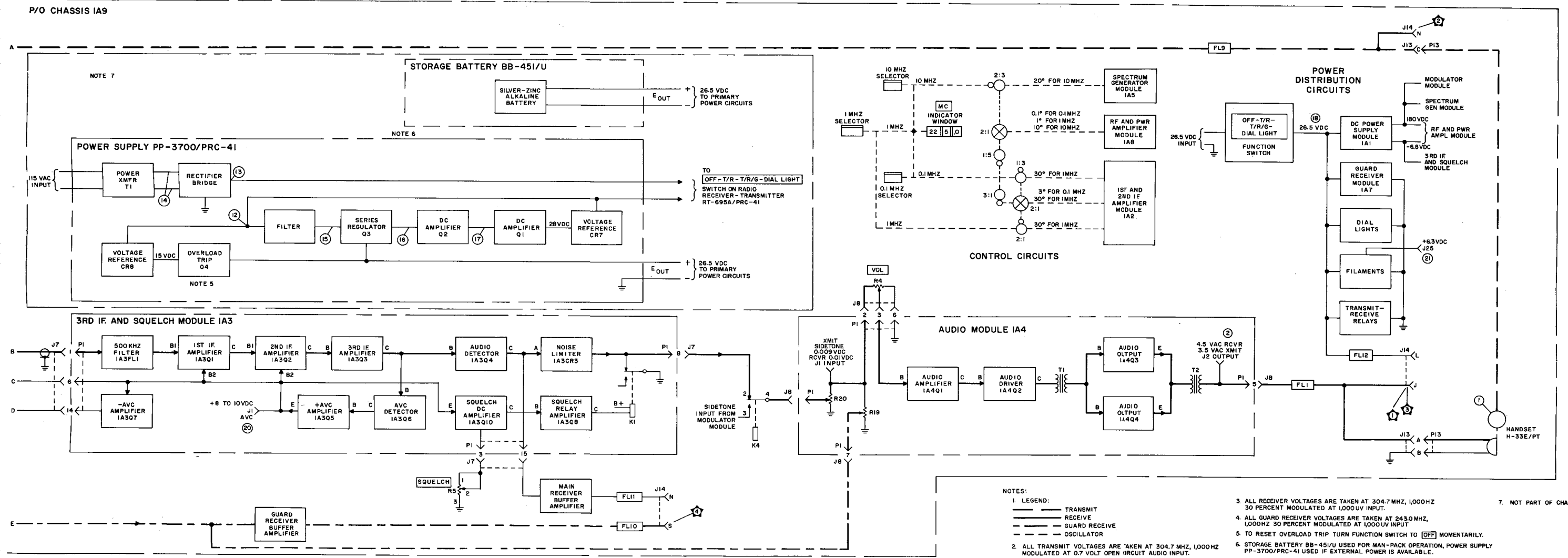

Figure 4-19. Radio Set AN/PRC-41A, Functional Section Servicing block diagram (Sheet 2 of 2)

Original

4-59, 4-60

## SECTION 5 MAINTENANCE

### 5-1. FAILURE, AND PERFORMANCE AND OPERATIONAL REPORTS.

#### Note

The Naval Electronics Systems Command no longer requires the submission of failure reports for all equipments. Failure reports and performance and operational reports are to be accomplished for designated equipments (refer to Electronics Installation and Maintenance Book, NavShips 900.000) only to the extent required by existing directives. All failures shall be reported for those equipments requiring the use of failure reports.

### 5-2. PREVENTIVE MAINTENANCE.

#### a. MAINTENANCE STANDARDS.

(1) GENERAL. - This section of the handbook provides complete and comprehensive preventive maintenance information so that proper equipment operation can be maintained.

(2) TEST EQUIPMENT AND SPECIAL TOOLS. -The following test equipment is required for performance of the preventive maintenance procedures of this section. No special tools are required.

- (a) Signal Generator AN/USM-44A.
- (b) Signal Generator AN/URM-25D.
- (c) RF Wattmeter AN/URM-43C
- (d) Oscilloscope AN/USM-105A.
- (e) Output Power Meter ME-2/U.
- (f) Audio Oscillator TS-382B/U.
- (g) Fuse MX-1730/U.
- (h) Electronic Multimeter TS-505/U.
- (i) Frequency Counter AN/USM-122.
- (j) Electronic Frequency Converter CV-394/USA-5.
- (k) Transfer Oscillator CM-102/USM-73.
- (l) Adjustable Attenuator CN-318/G.
- (m) Signal Generator Pad CN-315/URM-26.
- (n) Coaxial Crystal Detector HP-420A.
- (o) Power Resistor 204C.
- (p) Multimeter AN/PSM-4C.
- (q) Output Meter ME-6C/U.

(3) SPECIAL PROCEDURES. - Except for daily operational tests, all preventive maintenance tests are to be performed on a test bench having available the test equipment listed under paragraph 5-2a(2). Tests are to be performed with PP-3700/PRC-41 supplying required primary power. See figure 5-21. Initially, the OFF-T/R-T/ R/G-DIAL LIGHT switch should be in the OFF position for making required test setups.

(a) JUNCTION BOX. - Figure 5-1 illustrates schematically a junction box which is to be fabricated from bulk supplies. Preventive maintenance procedures make reference to and illustrate the use of this junction box. The junction box takes the place of H-33E/PT. It provides a means of keying the transmitter, a connection for audio outputs, and a dummy microphone load for signal input to RT-695A/PRC-41. Figure 5-2 provides a suggested layout for connectors and switches, identifying jacks and switch markings, and part numbers of the switch and connectors which must be used to be compatible with RT-695A/PRC-41 and the test equipment listed in paragraph 5-2a(2).

(b) Special Purpose Cable Assembly CX10831/PRC-41A Test. Refer to new figure 5-85.1 and 5-85.2 and perform a point-to-point continuity test (NMT 1.0 ohms). Use whichever figure is applicable.

#### (4) REFERENCE STANDARD PROCEDURES

#### NOTE

The procedures listed below consist of the minimum number of reference standards which will indicate, when completed, the relative performance of the equipment. Each group of tests represents a functional section of the equipment. The procedures are listed in the suggested sequence of performance; however, deviation from the listed order will in no way affect the results unless otherwise noted.

(5) PREVENTIVE MAINTENANCE PROCEDURES. (Refer to figures 5-4 through 5-20.) The following preventive maintenance procedures are arranged numerically within each maintenance period. Because of the nature of this equipment, all tests, except the daily operational tests, are to be performed on the test bench at a facility having the necessary test equipment. Bench performance tests are to be performed on a monthly and semiannual basis.

(6) PERIODIC SCHEDULE CHARTS. - The operator or faculty is to prepare periodic schedule charts for recording and checking the results obtained from the preventive maintenance procedures listed in reference standards procedures, table 5-1. Figure 5-3 provides examples of the sort of periodic schedule charts which are to be prepared. These charts are to run for a period of 2 years for each of the reference standard daily, monthly, or semiannual tests.

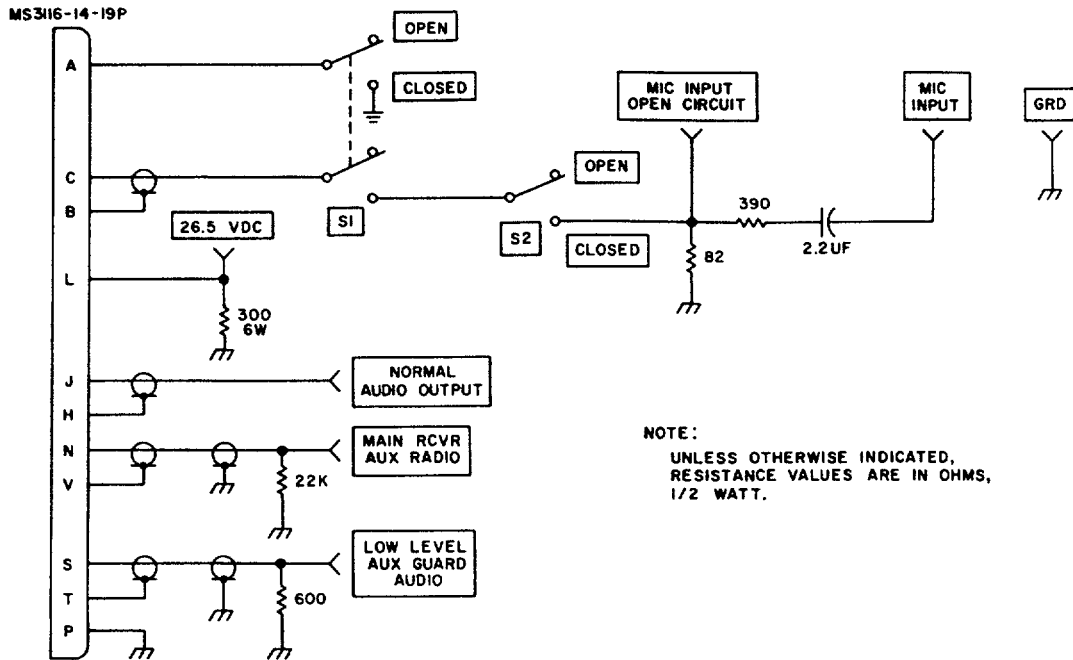

TPI-5047-013

Figure 5-1. Junction Box, Schematic Diagram

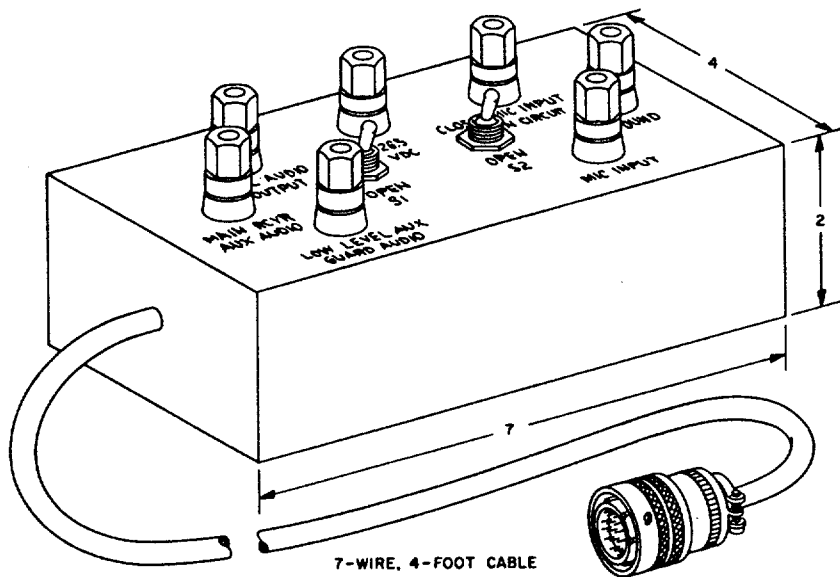

TPI-5046-013

Figure 5-2. Junction Box, Suggested Layout for Fabrication  
 5-2

**TABLE 5-1. REFERENCE STANDARDS PROCEDURES**

SECTION	ACTION REQUIRED	REFERENCE
Main receiver	Make operational check. Visually inspect gear train. Record sensitivity. Remove module covers to visually inspect detail parts. Record selectivity. Record avc characteristics. Record audio power output. Make audio capability check in addition to distortion check.	D1 M1 M4 SA1 SA2 SA4 SA5 SA8
Guard receiver	Make operational check. Record signal input level required to produce audio output. Record sensitivity. Record selectivity. Record avc characteristics. Record audio power output. Make audio capability check in addition to distortion check.	W1 M2 M3 SA3 SA6 SA7 SA9
Transmitter	Make operational check. Record power output. Record percentage of modulation. Record frequency stability. Record modulation fidelity and distortion.	D2 M5 M6 SA10 SA11
Power Supply PP-3700/PRC-41	Record 26.5-volt output supply voltage and ac ripple.	SA12

Enter the name of the month in which the maintenance step is begun in the first empty block of the top row. Fill in the names of the months consecutively thereafter for a period of two years. Log the result in appropriate space after performing step 1.

1st Year of Operation												2nd Year of Operation											
1																							
2																							
3																							
4																							
5																							
6																							
7																							
8																							

Time Schedule: Check (✓) if communications was established, and initial 1st Year of Operation.

Day	19__	19__	19__	19__	19__	19__	19__	19__	19__	19__	19__	19__
1												
2												
3												
4												
5												
6												
7												
8												
9												
10												
11												

Time Schedule: Record and Initial

1st year of Operation												
Month	19__	19__	19__	19__	19__	19__	19__	19__	19__	19__	19__	19__
Step												
Step												
Step												

2nd year of Operation												
Month	19__	19__	19__	19__	19__	19__	19__	19__	19__	19__	19__	19__
Step												
Step												
Step												

Figure 5-3. Examples of Periodic Schedule Charts To Be Prepared for Recording Preventive Maintenance Results

STEPS D1 and D2

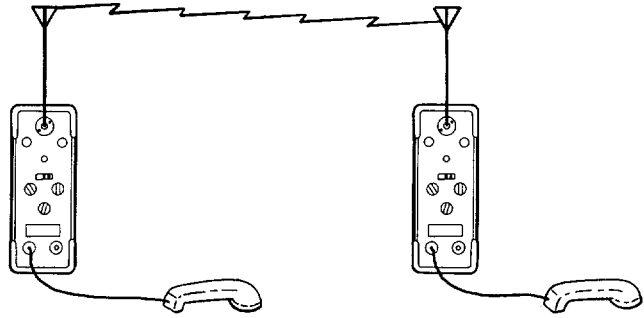

OPERATING CONDITIONS AND CONTROL SETTINGS:

OFF-T/R-T/R/G-DIAL LIGHT: OFF.  
SQUELCH: Fully counterclockwise.  
VOL: Fully clockwise, adjust for satisfactory reception.

STEP NO	ACTION REQUIRED	READ INDICATION ON	REFERENCE STANDARD
D1 and D2	Establish communications with another Radio Set AN/PRC-41A or other uhf transceiver.	Listen for signal in Handset H-33E/PT.	Ability to receive on main receiver and to transmit.
	PROCEDURE: Set OFF-T/R-T/R/G-DIAL LIGHT switch to T/R, and allow equipment 5 minutes warmup. Establish communication with a netting AN/PRC-41A equipment or other uhf transceiver. Press press-to-talk button on H-33E/PT for transmissions, release for reception.		

Figure 5-4. Preventive Maintenance Test, D1 and D2

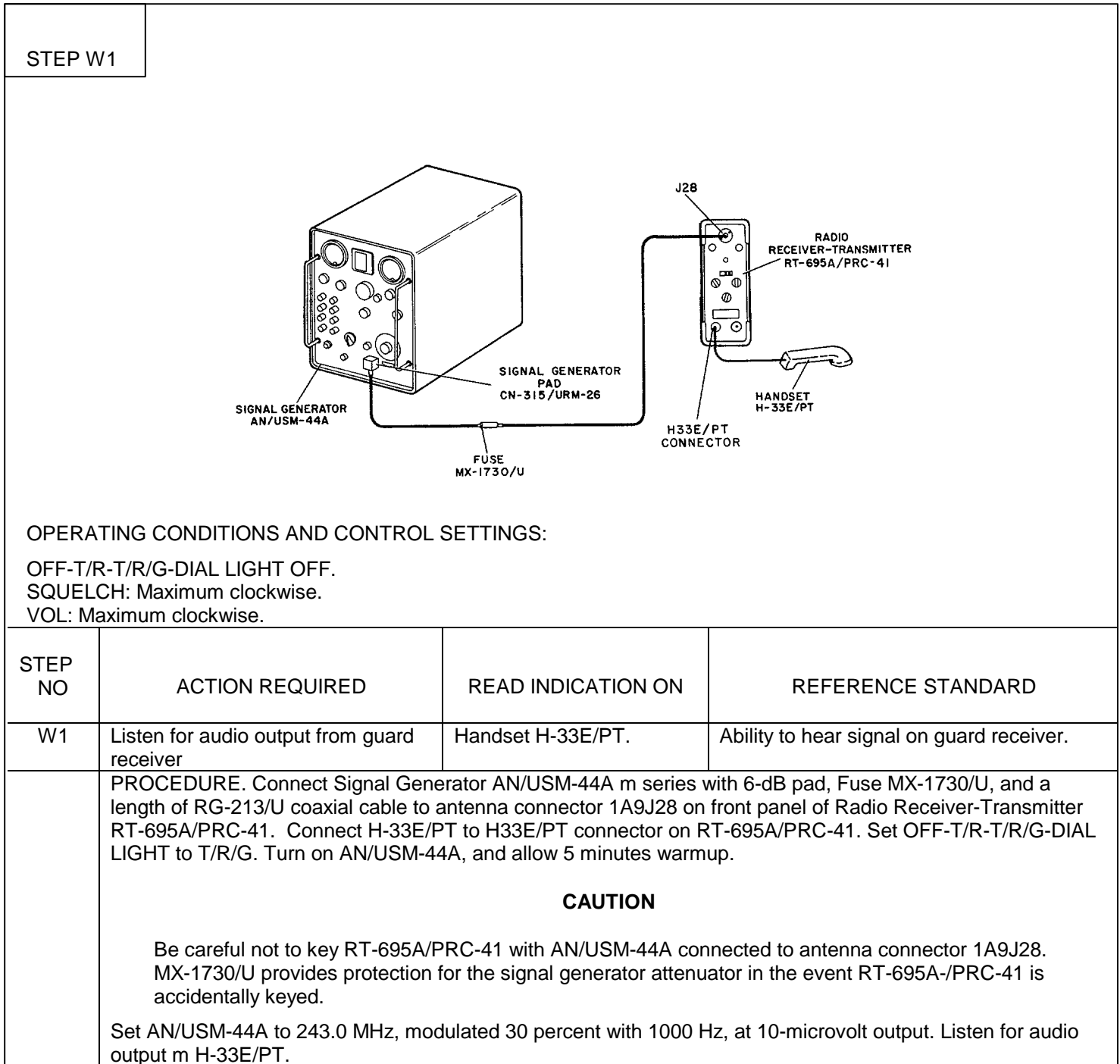

Figure 5-5. Preventive Maintenance Test, W1



STEP M1			
<p>OPERATING CONDITIONS AND CONTROL SETTINGS.</p> <p>Remove primary power from Radio Receiver-Transmitter RT-695A/PRC-41 and remove CY-3884/PRC-41 case.</p>			
STEP NO	ACTION REQUIRED	READ INDICATION ON	REFERENCE STANDARD
M1	Visually inspect main chassis gear train.	Visual.	Mechanically tuned modules can be adjusted mechanically by frequency adjustment of front panel frequency selector knobs. There shall be no evidence of damage.
<p>PROCEDURE: Remove primary power from RT-695A/PRC-41, and remove CY-3884/PRC-41 case. Inspect gear tram for evidence of wear and deterioration and excessive backlash. Rotate frequency selector knobs throughout their range.</p>			

Figure 5-6. Preventive Maintenance Test, M1

STEP M2

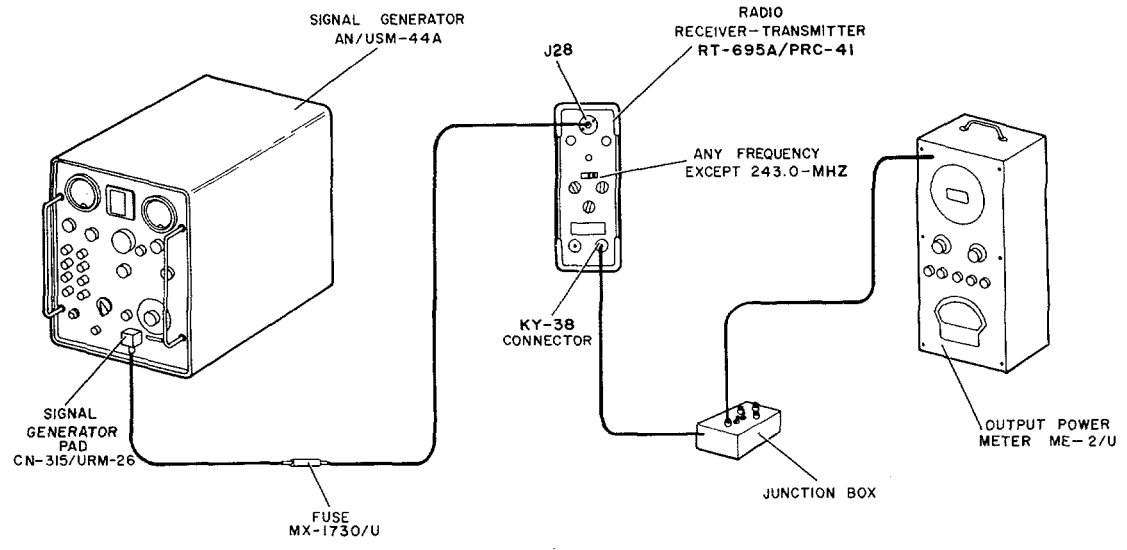

OPERATING CONDITIONS AND CONTROL SETTINGS:

OFF-T/R-T/R/G-DIAL LIGHT OFF.  
SQUELCH: Maximum clockwise  
VOL: Maximum clockwise.  
S1 and S2 switches (Junction box). Open position.

STEP NO	ACTION REQUIRED	READ INDICATION ON	REFERENCE STANDARD
M2	Record signal input level required to produce audio output from guard receiver.	Signal output level indicator on Signal Generator AN/ USM-44A and Output Power Meter ME-2/U.	Guard receiver should squelch on between 2 and 5 microvolts.
(Cont)	<p>PROCEDURE Connect AN/USM-44A in series with a 6-dB pad, Fuse MX-1730/U, and a length of RG-213/U coaxial cable to antenna connector 1A9J28 on front panel of Radio Receiver-Transmitter RT-695A/PRC-41. Connect junction box (figures 5-1 and 5-2) to KY-38 connector 1A9J14 on front panel of RT-695A/PRC-41. Connect ME-2/U to NORMAL AUDIO OUTPUT Jack on junction box. Turn on test equipment, and allow 10 minutes warmup. Adjust AN/USM-44A to 243.0 MHz, modulated 30 percent with 1000 Hz. Set OFF-T/R-T/R/G-DIAL LIGHT switch to T/R/G</p>		

Figure 5-7. Preventive Maintenance Test, M2 (Sheet 1 of 2)

			STEP M2
STEP NO	ACTION REQUIRED	READ INDICATION ON	REFERENCE STANDARD
M2 (Cont)	<p style="text-align: center;"><b>CAUTION</b></p> <p>Be careful not to key RT-695A/PRC-41 with AN/USM-44A connected to antenna connector 1A9J28. MX-1730/U provides protection in event RT-695A/PRC-41 is accidentally keyed. Application of transmitter output power to signal generator output will result in attenuator damage.</p> <p>Set the frequency selector knobs on front panel of RT-695A/PRC-41 to any frequency other than 243.0 ±5 MHz. Beginning with zero output from AN/USM-44A, increase output until an indication is obtained on ME-2/U.</p>		

Figure 5-7. Preventive Maintenance Test, M2 (Sheet 2 of 2)

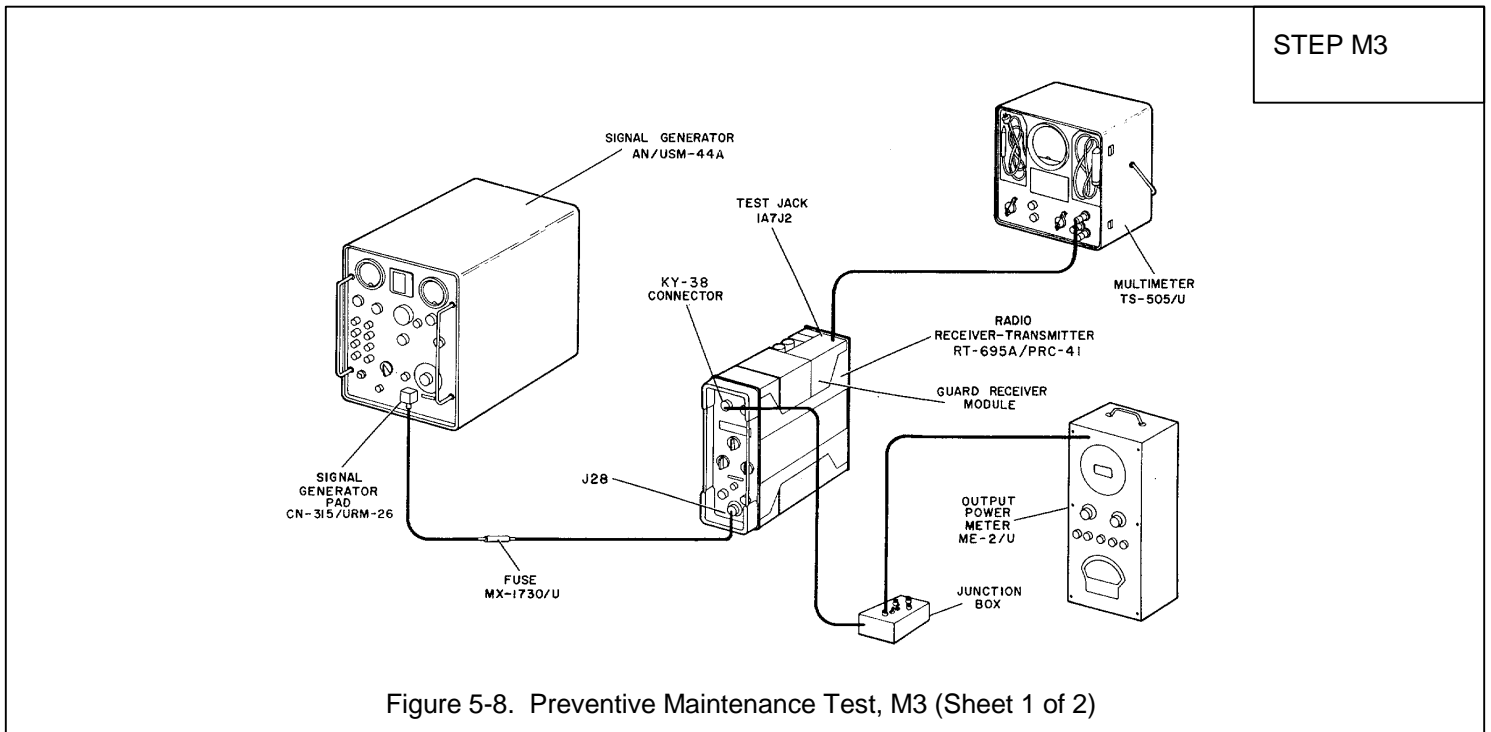

STEP M3			
OPERATING CONDITIONS AND CONTROL SETTINGS:  OFF-T/R-T/R/G-DIAL LIGHT: OFF. SQUELCH. Maximum clockwise. VOL: Maximum clockwise.			
STEP NO	ACTION REQUIRED	READ INDICATION ON	REFERENCE STANDARD
M3	Record guard receiver sensitivity.	Output Power Meter ME-2/U, Output Meter ME-6C/U.	NORMAL AUDIO SENSITIVITY 10 dB or more; LOW LEVEL AUX GUARD AUDIO sensitivity 6 dB or greater.
<p>PROCEDURE: Connect output of Signal Generator AN/USM-44A m series with a 6-dB pad through a length of RG-213/U coaxial cable to antenna connector 1A9J28 on front panel of Radio Receiver-Transmitter RT-695A/PRC-41. Connect junction box (figures 5-1 and 5-2) to KY-38 connector 1A9J14 on front panel of RT-695A/PRC-41 with switches in open position. Connect Meter ME-2/U to NORMAL AUDIO OUTPUT jack on junction box. Connect ME-6C/U to LOW LEVEL AUX GUARD AUDIO jack on junction box. Connect Electronic Multimeter TS-505/U to avc Jack 1A7J2 on guard receiver module.</p> <p style="text-align: center;">Note</p> <p style="text-align: center;">Main receiver module must be squelched off during guard receiver sensitivity test.</p> <p>Adjust AN/USM-44A to produce an output of 5 microvolts modulated 30 percent with 1000 Hz. Set OFF-T/R-T/R/G-DIAL LIGHT switch to T/R/G, and allow 5 minutes warmup. Adjust AN/ USM-44A to 243.0 MHz as indicated by a maximum avc voltage on TS-505/U. Record normal audio output LOW LEVEL AUX GUARD OUTPUT in decibels as measured on the ME-2/U and ME6C/U. Remove modulation, and again record ME-2/U and ME-6C/U indication. Signal-plus-noise to noise ratio is difference of recorded values with and without modulation.</p>			

Figure 5-8. Preventive Maintenance (Sheet 2 of 2)

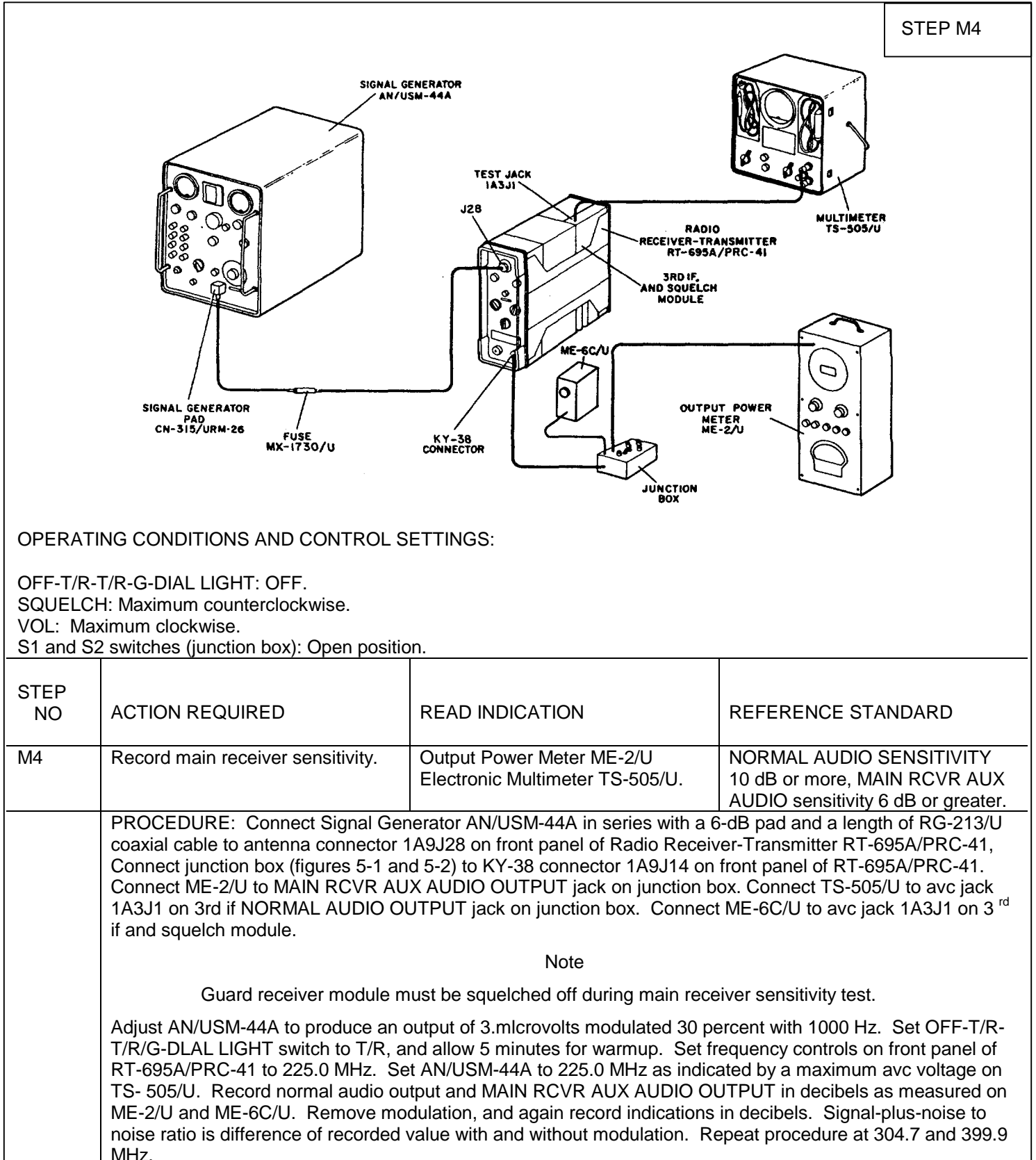

Figure 5-9. Preventive Maintenance Test, M4

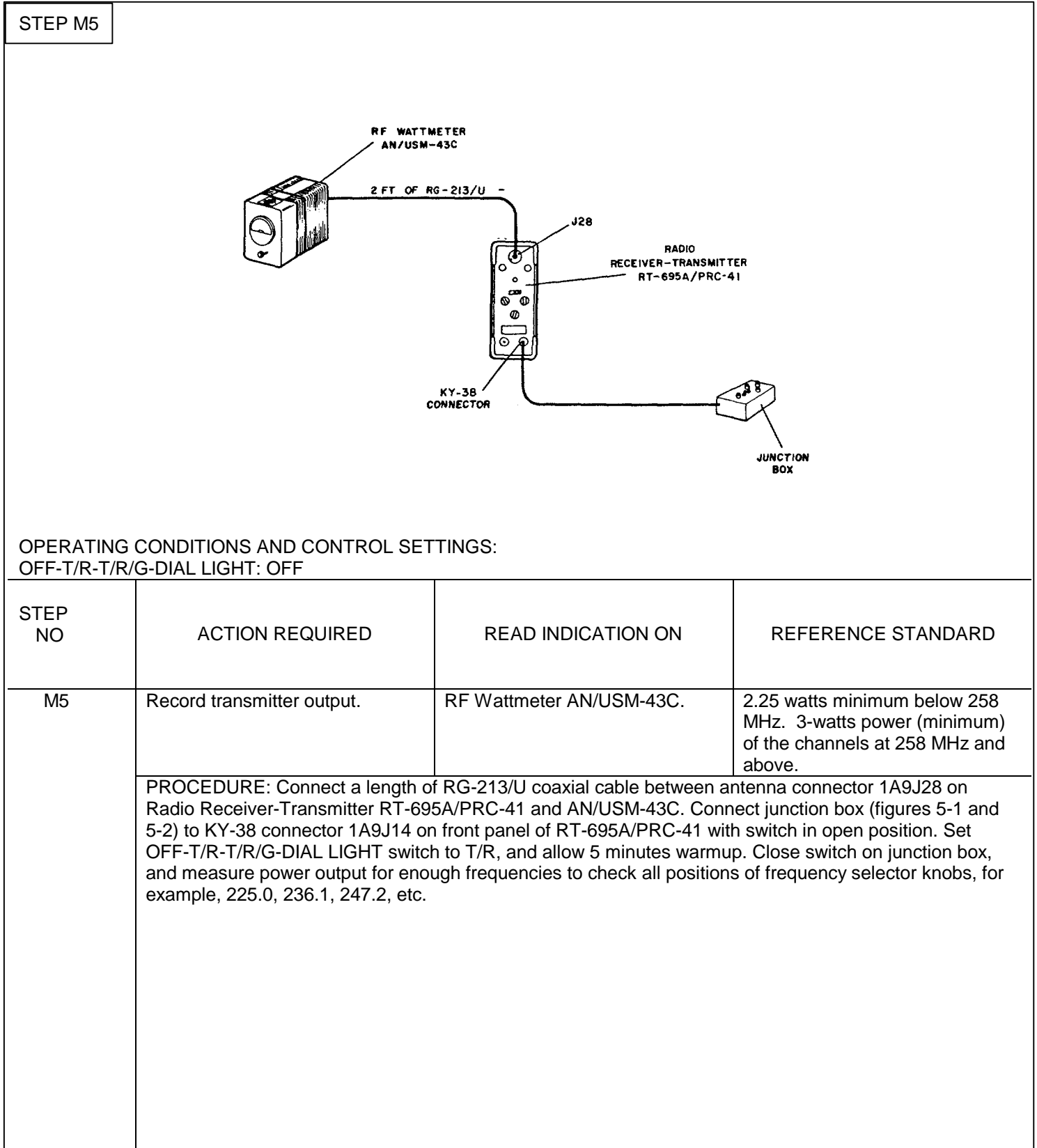

Figure 5-10. Preventive Maintenance Test, M5

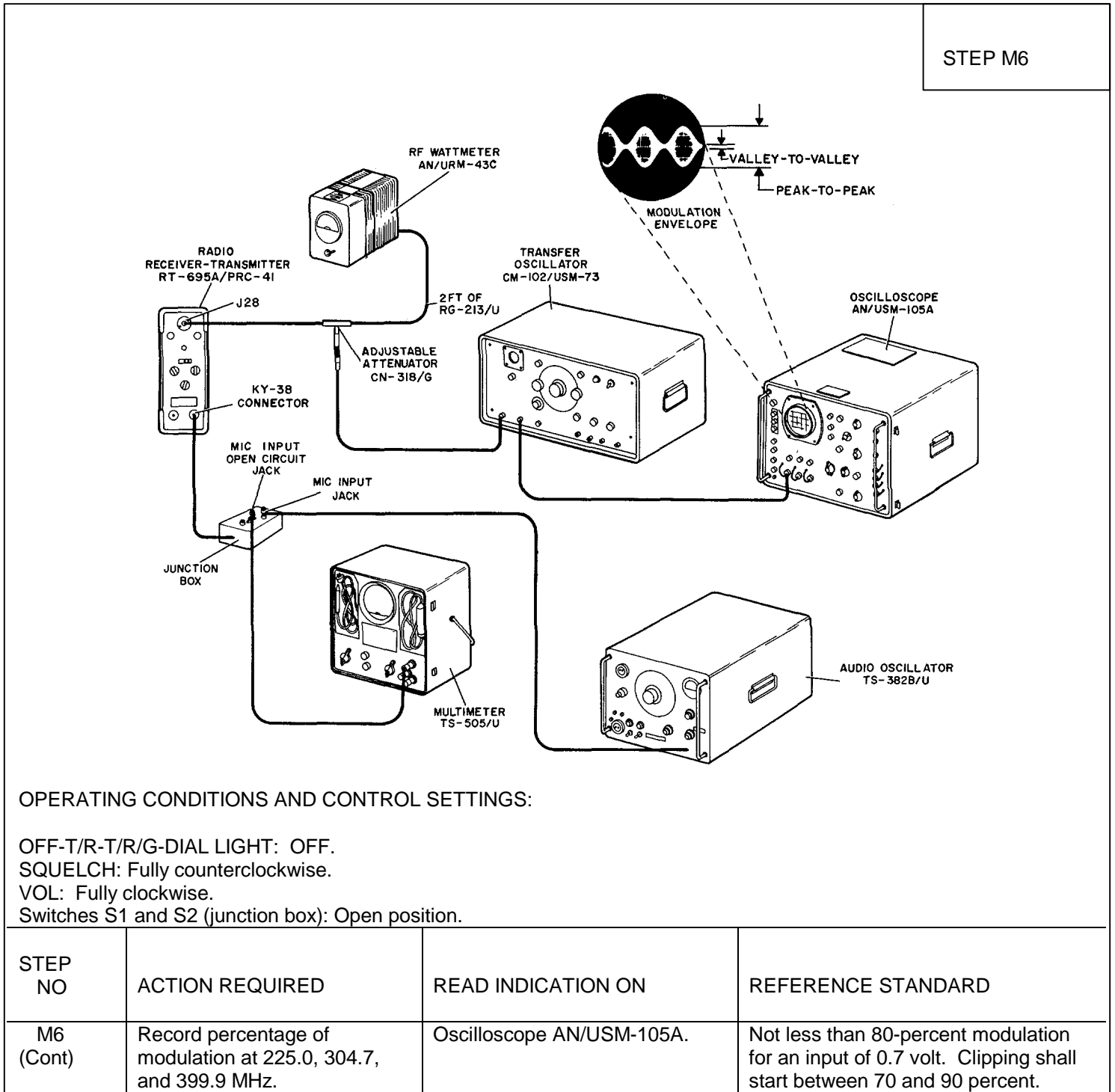

Figure 5-11. Preventive Maintenance Test, M 6 (Sheet 1 of 2)

STEP M6			
STEP NO	ACTION REQUIRED	READ INDICATION ON	REFERENCE STANDARD
M6 (Cont)	<p>PROCEDURE: Connect Adjustable Attenuator CN-318/G between antenna connector 1A9J28 on RT-695A/PRC-41 and RF Wattmeter AN/URM-43C using a 2-ft length of RG-213/U coaxial cable. Connect output of CN-318/G to input of Transfer Oscillator CM-102/USM-73. Connect VIDEO output of CM-102/USM-73 to Oscilloscope AN/USM-105A. Connect Audio 5-1 and 5-2 to KY-38 connector 1A9J14 on front panel of RT-695A/PRC-41. Connect Audio Oscillator TS-382B/U to MIC INPUT jack on junction box. Connect Electronic Multimeter TS-505/U to MIC INPUT (OPEN CIRCUIT) jack on junction box. Set OFF-T/R-T/G-DIAL LIGHT switch to T/R, and adjust frequency control knobs for a frequency of 225.0 MHz. Apply power to test equipment, and allow 10 minutes warmup. Close switch S1 on junction box, and adjust frequency of CM-102/USM-73 to produce a difference frequency of approximately 200 kHz on AN/USM-105A. Adjust signal input level of TS-382B/U for 0.7 volt (open circuit) at 1000 Hz as measured on TS-505/U. Remove TS-505/U from the MIC INPUT (OPEN CIRCUIT) jack. Close switch S2 on junction box, and adjust AN/USM-105A to obtain a modulation envelope pattern. Calculate percentage of modulation according to following formula:</p> $\text{Percent modulation} = \frac{(P \text{ to } P) - (V \text{ to } V) \times 100}{(P \text{ to } P) + (V \text{ to } V)}$ <p>Check percent of modulation at 304.7 and 399.9 MHz.</p>		

Figure 5-11. Preventive Maintenance Test, M 6 (Sheet 2 of 2)

STEP SA1			
OPERATING CONDITIONS AND CONTROL SETTINGS			
Remove primary power from Radio Receiver-Transmitter RT-695A/PRC-41, and remove CY-3884/PRC-41 case.			
STEP NO	ACTION REQUIRED	READ INDICATION ON	REFERENCE STANDARD
SA1	Visually inspect detail parts	Visual.	Detail parts and wiring of modules of RT-695A/PRC-41 shall show no Visual evidence of damage or deterioration.
	<p>PROCEDURE: Remove RT-695A/PRC-41 modules from main chassis Remove module side covers, and visually inspect each module for evidence of charred or discolored wiring and detail parts, or other indications of damage.</p>		

Figure 5-12. Preventive Maintenance Test, SA1



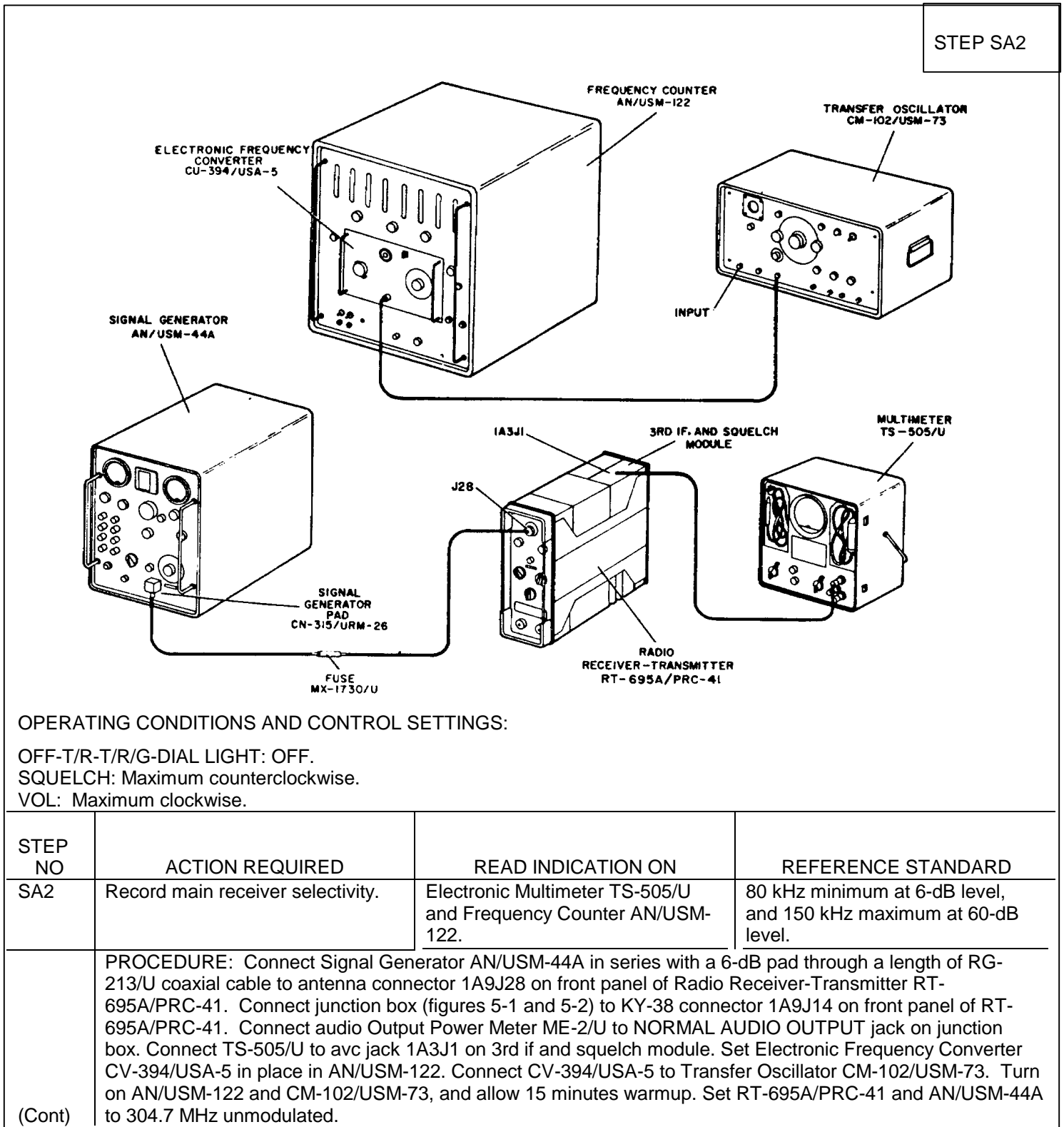
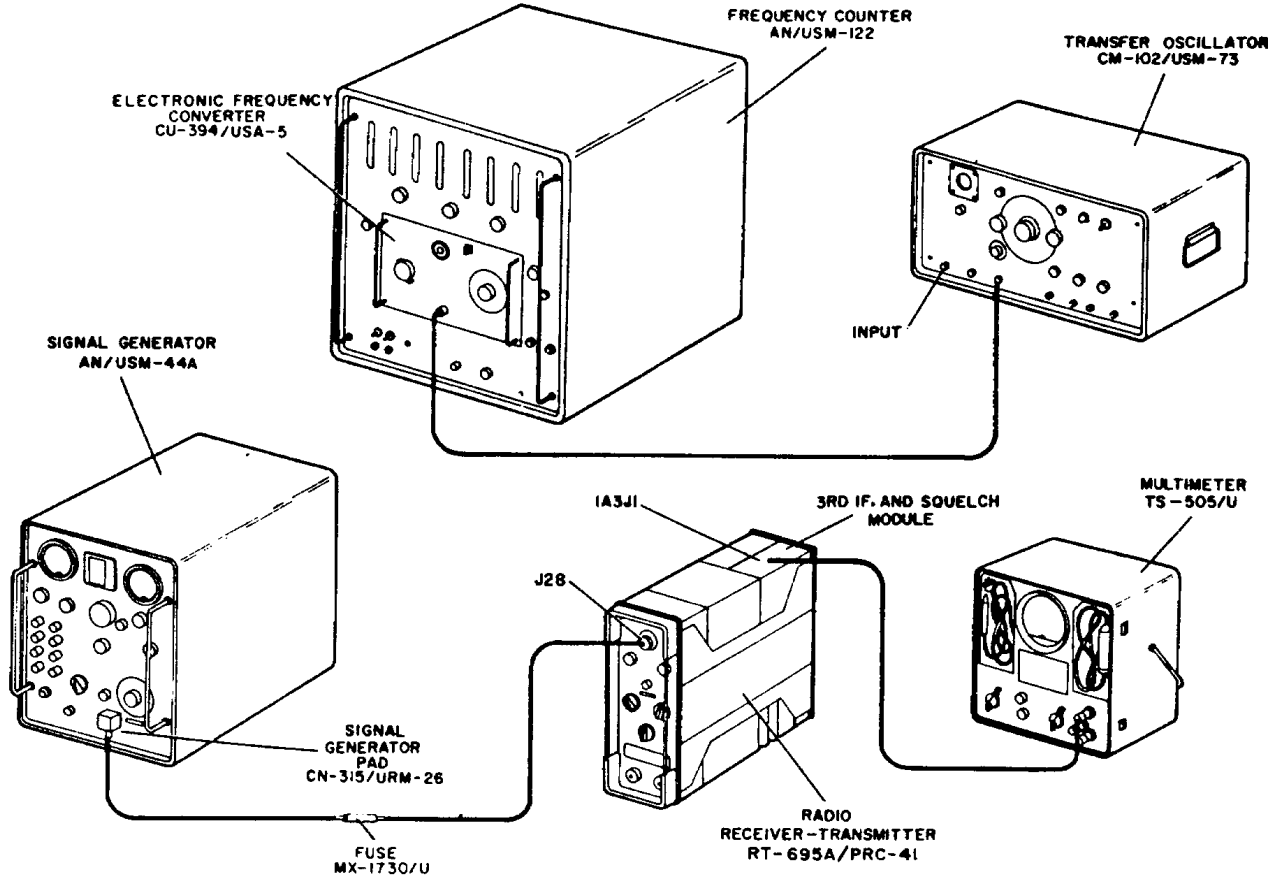

Figure 5-13. Preventive Maintenance Test, SA2 (Sheet 1 of 2)

STEP SA2			
STEP NO	ACTION REQUIRED	READ INDICATION ON	REFERENCE STANDARD
SA2 (Cont)	<p style="text-align: center;">Note</p> <p>AN/USM-44A must be accurately tuned to 304.7 MHz to give correct indications of bandwidth.</p> <p>Set OFF-T/R-T/R/G-DIAL LIGHT switch to T/R, and apply power to AN/USM-44A. Allow 5 minutes warmup. Increase signal output from AN/USM-44A until a main receiver avc reference level of approximately +7 volts is indicated on TS-505/U. Increase AN/USM-44A signal output 6 dB. Increase output frequency of AN/USM-44A until TS-505/U again indicates avc reference level. Remove AN/USM-44A output connection from 1A9J28 on front panel of RT-695A/PRC-41, connect it to input of CM-102/USM-73, and record frequency at this point. Reconnect output of AN/USM-44A to 1A9J28 on RT-695A/PRC-41, decrease output frequency until avc reference level is again obtained, and record frequency at this point. The difference between two measured frequencies is bandwidth at 6-dB point. Repeat this procedure at 60-dB level.</p>		

Figure 5-13. Preventive Maintenance Test, SA2 (Sheet 2 of 2)

STEP SA3



OPERATING CONDITIONS AND CONTROL SETTINGS:

OFF-T/R-T/R/G-DIAL LIGHT: OFF.  
SQUELCH: Maximum clockwise.  
VOL: Maximum clockwise.

STEP NO	ACTION REQUIRED	READ INDICATION ON	REFERENCE STANDARD
SA3 (Cont)	Record guard receiver selectivity.	Electronic Multimeter TS-505/U and Frequency Counter AN/USM-122.	50 kHz minimum at 6-dB point, and 200 kHz maximum at 60-dB level.
<p>PROCEDURE: Connect Signal Generator AN/USM-44A in series with a 6-dB pad through a length of RG-213/U coaxial cable to antenna connector 1A9J28 on front panel of Radio Receiver-Transmitter RT-695A/PRC-41, Connect TS-505/U to avc jack 1A7J2 on guard receiver module. Set Electronic Frequency Converter CV-394/USA-5 in place in AN/USM-122. Connect Electronic Frequency Converter CV-394/USA-5 to Transfer Oscillator CM-102/USM-73. Turn on AN/USM-122 and CM-102/USM-73, and allow 15 minutes warmup. Set OFF-T/R-T/R/G-DIAL LIGHT switch to T/R/G, and apply power to AN/USM-44A. Allow 5 minutes warmup. Accurately tune AN/USM-44A</p>			

Figure 5-14. Preventive Maintenance Test, SA3 (Sheet 1 of 2)

SA3			
STEP NO	ACTION REQUIRED	READ INDICATION ON	REFERENCE STANDARD
SA3 (Cont)	<p>to 243.0 MHz unmodulated. Increase signal output from AN/USM-44A until a guard receiver avc reference level of approximately +3 volts is indicated on TS-505/U. Increase AN/USM-44A signal output 6 dB. Increase output frequency of AN/USM-44A until TS-505/U again indicates avc reference level. Remove AN/USM-44A output connection from 1A9J28 on front panel of RT-695A/ PRC-41, connect it to input of CM-102/USM-73, and record frequency at this point. Reconnect output of AN/USM-44A to antenna connector 1A9J28 on RT-695A/PRC-41, decrease output frequency until avc reference level is again obtained, and record frequency at this point. Repeat this procedure at 60-dB level.</p> <p style="text-align: center;"><b>CAUTION</b></p> <p>Be careful not to key RT-695A/PRC-41 with AN/USM-44A connected to antenna connector 1A9J28. Fuse MX-1730/U provides protection in event RT-695A/PRC-41 is accidentally keyed. Application of transmitter output power to signal generator output will result in attenuator damage.</p>		

Figure 5-14. Preventive Maintenance Test, SA3 (Sheet 2 of 2)

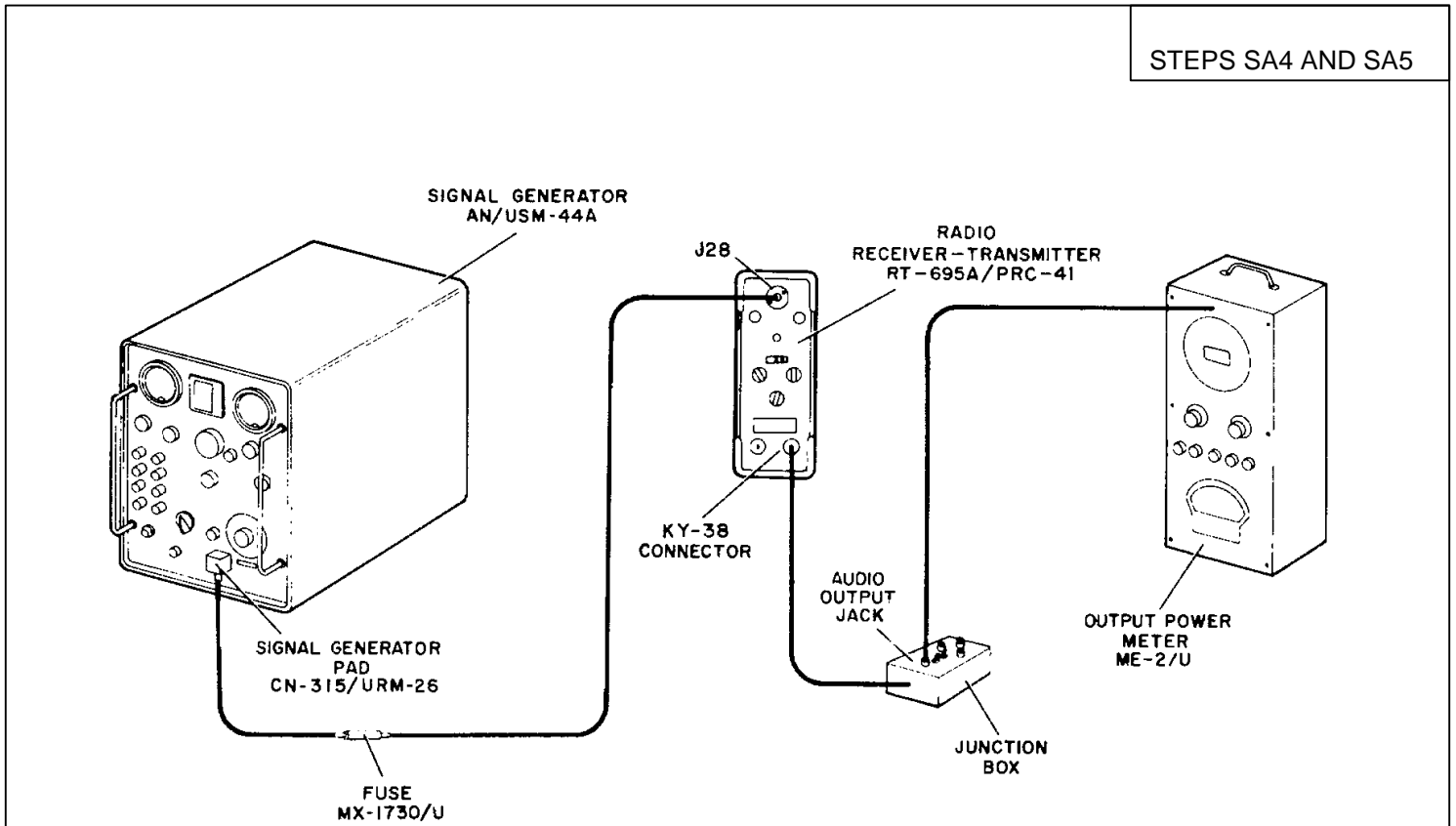

STEPS SA4 AND SA5

**OPERATING CONDITIONS AND CONTROL SETTINGS:**

OFF-T/R-T/R/G-DIAL LIGHT: OFF.  
SQUELCH: Maximum counterclockwise. VOL: Maximum clockwise.  
S1 and S2 switches (junction box): Open position.

STEP NO	ACTION REQUIRED	READ INDICATION ON	REFERENCE STANDARD
SA4	Record main receiver and main receiver auxiliary audio avc characteristics.	Output Power Meter ME-2/U, Output Meter ME-6C/U.	Audio power output and AUX audio output shall not vary more than $\pm 3$ dB from 1000-microvolt reference over 10- to 100,000-microvolt range and shall not block for signals less than 0.5-volt input for all frequencies.

**PROCEDURE:** Connect Signal Generator AN/USM-44A through a 6-dB pad and a length of RG-213/U coaxial cable to antenna connector 1A9J28 on RT-695A/PRC-41. Connect junction box (figures 5-1 and 5-2) to KY-38 connector 1A9J14 on RT-695A/PRC-41. Connect ME-2/U to NORMAL AUDIO OUTPUT jack on junction box. Connect ME-6C/U to MAIN RCVR AUX AUDIO jack on junction box. Set OFF-T/R-T/R/G-DIAL LIGHT switch to T/R, and apply power to test equipment. Allow 10 minutes warmup. Set AN/USM-44A to 231.2 MHz modulated 30 percent with 1000 Hz at 1000 microvolts. Note normal audio power output indication on ME-2/U and MAIN RCVR AUX AUDIO output indication on ME-6C/U with RT-695A/PRC-41 tuned to 231.2 MHz. Vary signal input level to RT-695A/PRC-41 from 10 to 100,000 microvolts, and record the normal audio power output and MAIN RCVR AUX AUDIO output changes in decibels from 1000-microvolt reference. Increase signal input to 0.5 volt, and check to see that blocking does not occur. Repeat these measurements at 304.7 and 399.9 MHz.

Figure 5-15. Preventive Maintenance Test, SA4 and SA5 (Sheet 1 of 2)

STEPS SA4 AND SA5			
STEP NO	ACTION REQUIRED	READ INDICATION ON	REFERENCE STANDARD
SA5	Record main receiver audio power output and auxiliary audio output.	Output Power Meter ME-2/U, Output Meter ME-6C/U.	Normal audio output shall be at least 50 milliwatts, MAIN RCVR AUX audio output shall be at least 0.25 volt.
<p>PROCEDURE: Connect Signal Generator AN/USM-44A through a 6-dB pad and length of RG-213/U coaxial cable to antenna connector 1A9J28 on RT-695A/PRC-41. Connect junction box (figures 5-1 and 5-2) to KY-38 connector 1A9J14 on RT-695A/PRC-41. Connect ME-2/U to NORMAL AUDIO AUDIO OUTPUT jack on junction box. Connect ME-6C/U to MAIN RCVR AUX AUDIO output jack on junction box. Set OFF-T/R-T/R/G-DIAL LIGHT switch to T/R, and apply power to test equipment. Allow 10 minutes warmup. Set AN/USM-44A to 304.7 MHz modulated 30 percent with 1000 Hz at 1000 microvolts. Record normal audio power output and MAIN RCVR AUX AUDIO output.</p>			

Figure 5-15. Preventive Maintenance Test, SA4 and SA5 (Sheet 2 of 2)

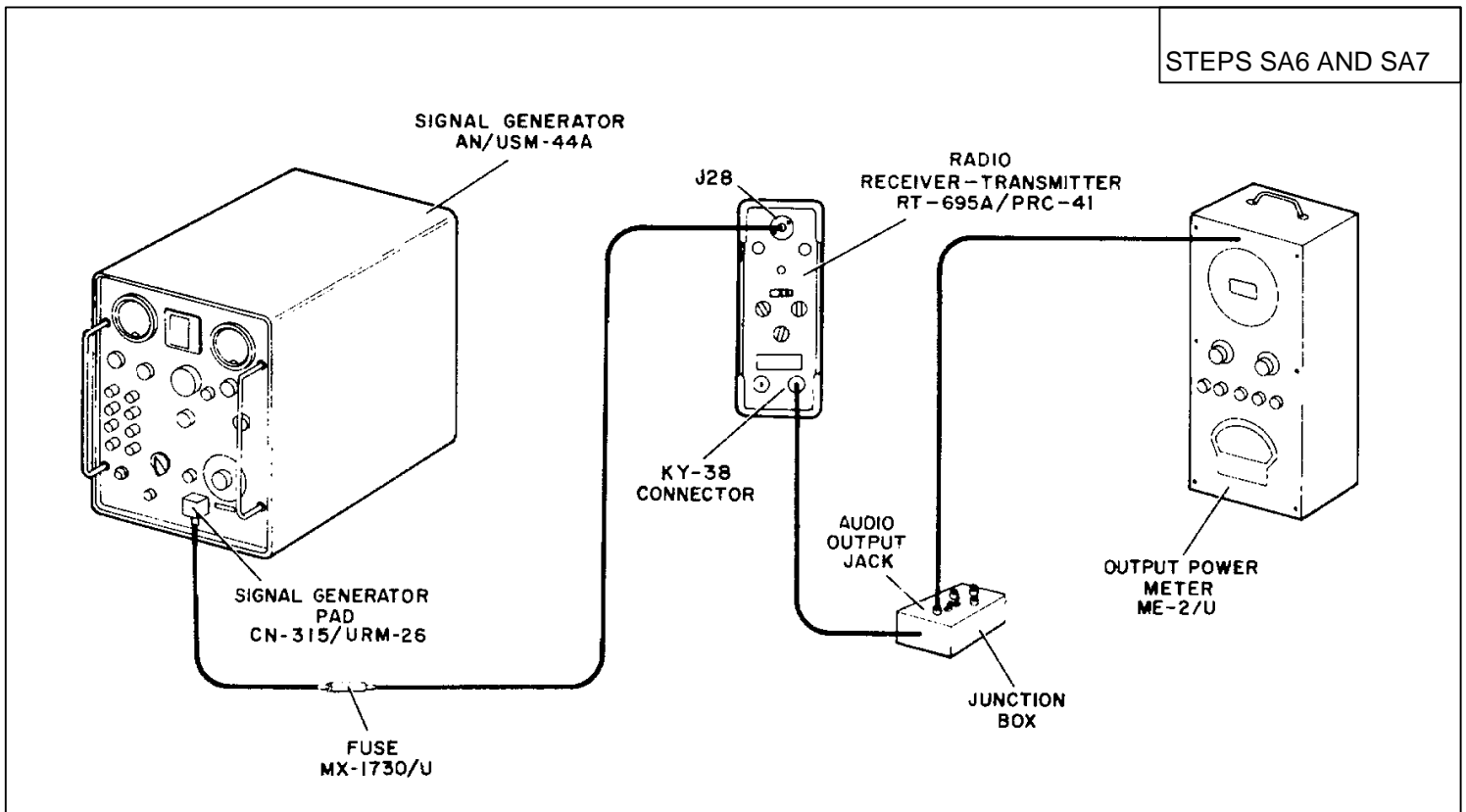

Figure 5-16. Preventive Maintenance Test, SA6 and SA7 (Sheet 1 of 2)

STEPS SA6 AND SA7			
OPERATING CONDITIONS AND CONTROL SETTINGS: OFF-T/R-T/R/G-DIAL LIGHT: OFF. SQUELCH: Maximum clockwise. VOL: Maximum clockwise. S1 and S2 switches (junction box): Open position.			
STEP NO	ACTION REQUIRED	READ INDICATION ON	REFERENCE STANDARD
SA6	Record guard receiver and low-level auxiliary guard audio avc characteristics.	Output Power Meter ME-2/U, Output Meter ME-6C/U.	Normal audio power output and LOW LEVEL AUX GUARD AUDIO shall not vary more than $\pm 3$ dB from 1000-microvolt reference over 10- to 100,000-microvolt range and shall not block signals less than 0.5-volt input for all frequencies.
PROCEDURE: Connect Signal Generator AN/USM-44A through a 6-dB pad and a length of RG-213/U coaxial cable to antenna connector 1A9J28 on RT-695A/PRC-41. Connect junction box (figures 5-1 and 5-2) to KY-38 connector 1A9J14 on RT-695A/PRC-41. Connect ME-2/U to NORMAL AUDIO OUTPUT jack on junction box. Connect ME-6C/U to LOW LEVEL AUX GUARD OUTPUT jack on junction box. Set OFF-T/R-T/R/G-DIAL LIGHT switch to T/R/G. Apply power to test equipment, and allow 10 minutes warmup. Adjust AN/USM-44A to 243.0 MHz modulated 30 percent with 1000 Hz at 1000 microvolts. Note audio power output indication on ME-2/U and LOW LEVEL AUX GUARD OUTPUT indication on ME-6C/U with RT-695A/PRC-41 tuned to 231.2 MHz. Vary signal input level to RT-695A/PRC-41 from 10 to 100,000 microvolts, and record audio power output and LOW LEVEL AUX GUARD OUTPUT changes in decibels from 1000-microvolt reference. Increase signal input to 0.5 volt, and check to see that blocking does not occur.			
SA7	Record guard receiver audio power output, and low-level auxiliary guard audio output.	Output Power Meter ME-2/U, Output Meter ME-6C/U.	Normal audio output shall be at least 50 milliwatts. LOW LEVEL AUX GUARD AUDIO OUTPUT shall be at least 0.15 volt.
PROCEDURE: Connect AN/USM-44A through a 6-dB pad and length of RG-213/U coaxial cable to antenna connector 1A9J28 on RT-695A/PRC-41. Connect junction box to KY-38 connector 1A9J14 on RT-695A/PRC-41. Connect ME-2/U to NORMAL AUDIO OUTPUT jack on junction box. Connect ME-6C/U to LOW LEVEL AUX GUARD OUTPUT jack on junction box. Set OFF-T/R-T/R/G-DIAL LIGHT switch to T/R/G. Apply power to test equipment, and allow 10 minutes warmup. Set AN/USM-44A to 243.0 MHz, modulated 30 percent with 1000 Hz at 1000 microvolts. Record NORMAL AUDIO OUTPUT and LOW LEVEL AUX GUARD OUTPUT.			

Figure 5-16. Preventive Maintenance Test, SA6 and SA7 (Sheet 2 of 2)

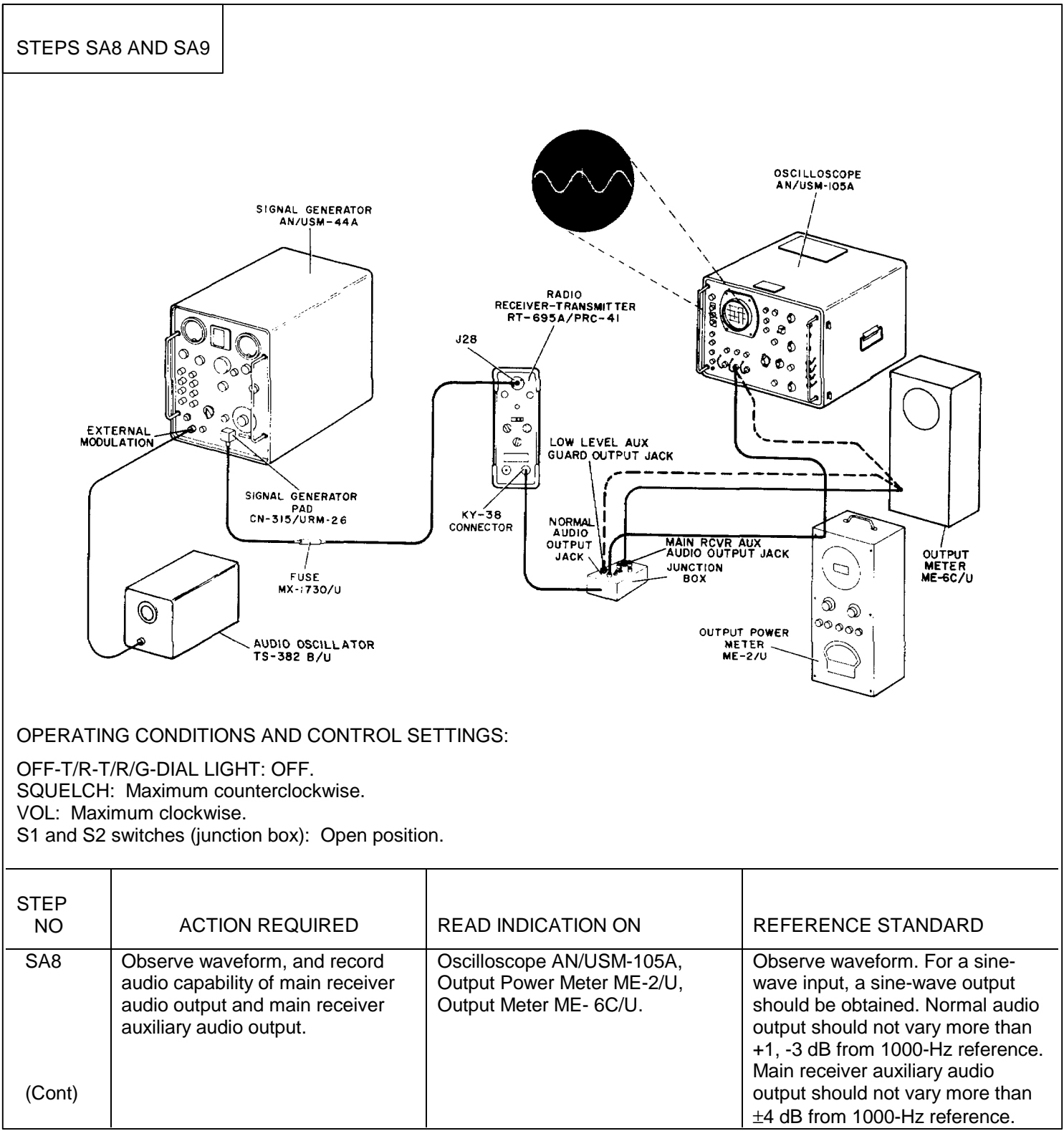

Figure 5-17. Preventive Maintenance Test, SA8 and SA9 (Sheet 1 of 2)



STEPS SA8 AND SA9			
STEP NO	ACTION REQUIRED	READ INDICATION ON	REFERENCE STANDARD
SA8 (Cont)	<p>PROCEDURE: Connect Signal Generator AN/USM-44A through a 6-dB pad and a length of RG-213/U coaxial cable to antenna connector 1A9J28 on RT-695A/PRC-41. Connect Audio Oscillator TS-382B/U to external modulation input jack on AN/USM-44A. Connect junction box (figures 5-1 and 5-2) to KY-38 connector 1A9J14 on RT-695A/PRC-41. Connect ME-2/U to NORMAL AUDIO OUTPUT jack on junction box. Connect ME-6C/U to MAIN RCVR AUX AUDIO output jack on junction box. Connect AN/USM-105A to NORMAL AUDIO OUTPUT jack on junction box. Set OFF-T/R-T/R/G-DIAL LIGHT switch to T/R, and apply power to test equipment. Allow 10 minutes warmup. Tune RT-695A/PRC-41 to 225.0 MHz, and set AN/USM-44A to 225.0 MHz externally modulated 30 percent with 1000 Hz at 1000 microvolts. Observe main receiver audio output waveform on AN/USM-105A for evidence of distortion. Connect AN/USM-105A to MAIN RCVR AUX AUDIO output jack on junction box. Observe main receiver auxiliary audio output waveform on AN/USM-105A for evidence of distortion. Note normal audio output indication on ME-2/U and main receiver auxiliary audio output indication on ME-6C/U. Vary frequency of TS-832B/U from 300 to 3500 Hz maintaining 30-percent modulation of AN/USM-44A, and measure the change of main receiver audio output in decibels from 1000-Hz reference as indicated on ME-2/U. Vary the frequency of TS-382B/U from 300 Hz to 20 kHz maintaining 30-percent modulation of AN/USM-44A, and measure the change of main receiver auxiliary audio output in decibels from 1000-Hz reference as indicated on ME-6C/U. Repeat procedure for 304.7 and 399.9 MHz.</p>		
SA9	Observe waveform, and record audio capability of guard audio output and low-level auxiliary guard output.	Oscilloscope AN/USM-105A, Output Power Meter ME2/U, Output Meter ME-6C/U.	Observe waveform. For a sine-wave input, a sine-wave output should be obtained. Normal audio output and low-level auxiliary guard output should not vary more than +1, -3 dB from 1000-Hz reference.
	<p>PROCEDURE: Connect Signal Generator AN/USM-44A through a 6-dB pad and a length of RG-213/U coaxial cable to antenna connector 1A9J28 on RT-695A/PRC-41. Connect Audio Oscillator TS-382B/U to external modulation input jack on AN/USM-44A. Connect junction box (figures 5-1 and 5-2) to KY-38 connector 1A9J14 on RT-695A/PRC-41. Connect ME-2/U to NORMAL AUDIO OUTPUT jack on junction box. Connect ME-6C/U to LOW-LEVEL AUX GUARD output jack on junction box. Connect AN/USM-105A to NORMAL AUDIO OUTPUT jack on junction box. Set SQUELCH control on RT-695A/PRC-41 maximum clockwise, and set OFF-T/R-T/R/G-DIAL LIGHT switch to T/R/G. Apply power to test equipment and allow 10 minutes warmup. Set RT-695A/PRC-41 main receiver frequency controls to any frequency other than 243.0 +5 MHz. Set AN/USM-44A to 243.0 MHz, externally modulated 30 percent with 1000 Hz at 1000 microvolts. Observe guard receiver audio output waveform on AN/USM-105A for evidence of distortion. Connect AN/USM-105A to LOW-LEVEL AUX GUARD output jack on junction box. Observe low-level auxiliary guard audio output waveform on AN/USM-105A for evidence of distortion. Note normal audio output indication on ME-2/U and low-level auxiliary guard output indication on ME-6C/U. Vary frequency of TS-382B/U from 300 to 3500 Hz maintaining 30-percent modulation of AN/ USM-44A. Measure the change of guard receiver audio output in decibels from 1000-Hz reference as indicated on ME-2/U, and measure the change of low-level auxiliary guard audio output in decibels from 1000-Hz reference as indicated on ME-6C/U.</p>		

Figure 5-17. Preventive Maintenance Test, SA8 and SA9 (Sheet 2 of 2 )

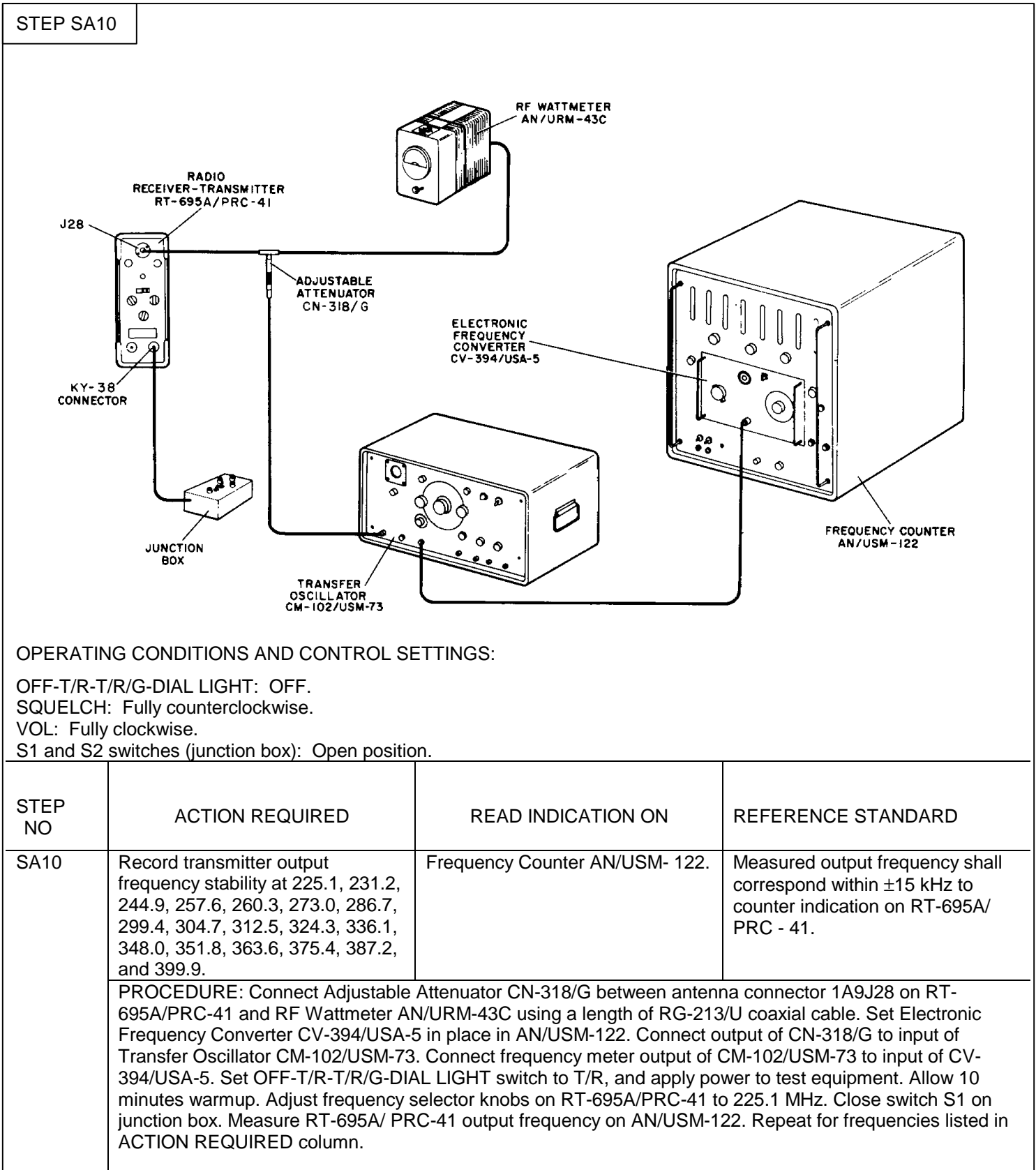
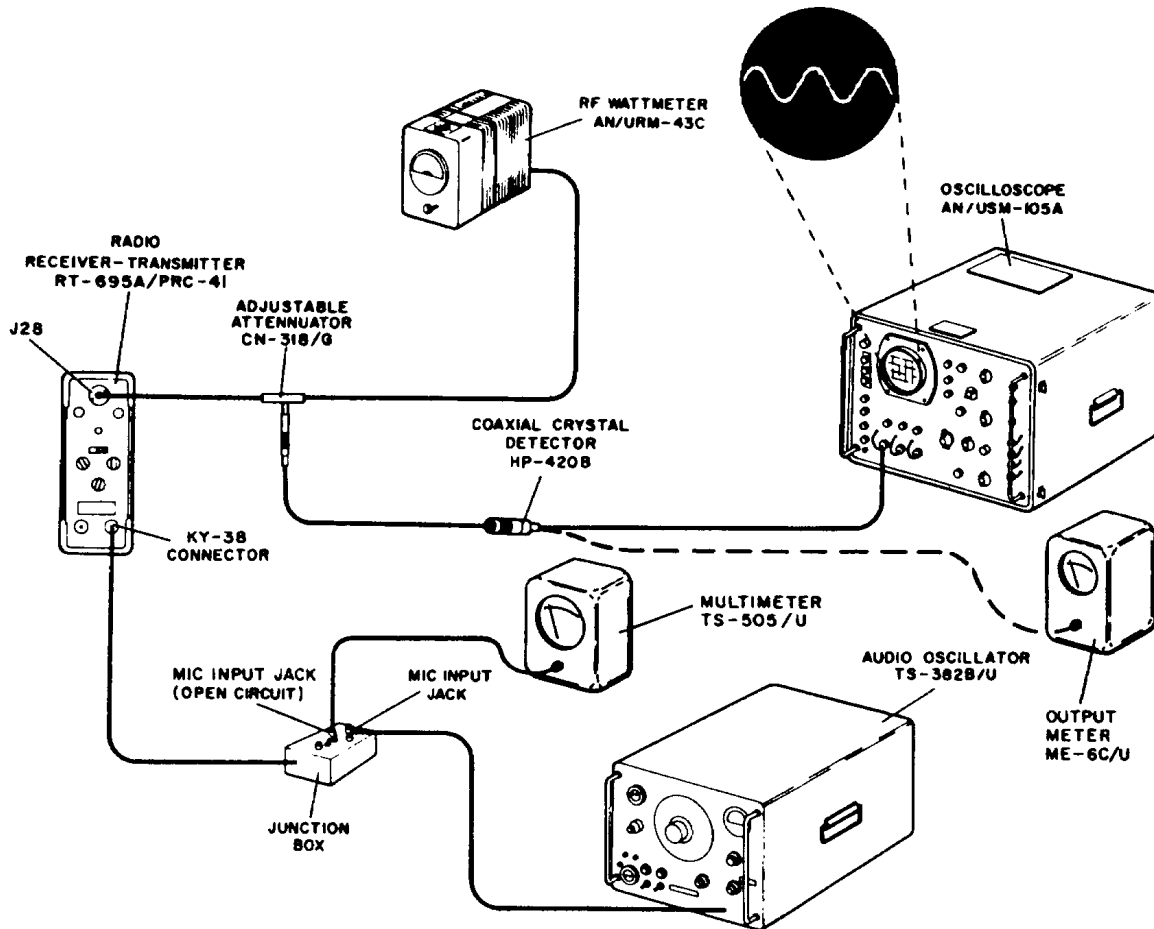

Figure 5-18. Preventive Maintenance Test, SA10

STEP SA11



OPERATING CONDITIONS AND CONTROL SETTINGS:

OFF-T/R-T/R/G-DIAL LIGHT: OFF.

S1 and S2 switches (junction box): Open position.

STEP NO	ACTION REQUIRED	READ INDICATION ON	REFERENCE STANDARD
SA11	Observe transmitter output waveform, and record modulation fidelity.	Oscilloscope AN/USM-105A, Output Meter ME-6C/U.	Observe waveform. For a sine-wave input, a sine-wave output should be obtained. Modulation frequency response should not vary more than $\pm 4$ dB from 1000-Hz reference.
(Cont)	<p>PROCEDURE: Connect Adjustable Attenuator CN-318/G to antenna connector 1A9J28 on RT-695A/ PRC-41. Connect RF Wattmeter AN/URM-43C to CN-318G using a length of RG-213/U coaxial cable. Attach Coaxial Crystal Detector HP-420B to output of CN-318G, and connect HP-420B output to AN/USM-105A. Connect junction box (figures 5-1 and 5-2) to KY-38 connector 1A9J14 on RT-695A/PRC-41. Connect Audio Oscillator TS-382B/U to MIC INPUT jack on junction box, and</p>		

Figure 5-19. Preventive Maintenance Test, SA11 (Sheet 1 of 2)

STEP SA11			
STEP NO	ACTION REQUIRED	READ INDICATION ON	REFERENCE STANDARD
SA11 (Cont)	connect Electronic Multimeter TS-505/U to MIC INPUT (OPEN CIRCUIT) jack on junction box. Tune RT-695A/PRC-41 to 304.7 MHz, and set OFF-T/R-T/R/G-DIAL LIGHT switch to T/R. Apply power to test equipment, and allow 10 minutes warmup. Set TS-382B/U for 1000 Hz at a signal output level to indicate 0.5 volt on TS-505/U. Close switches S1 and S2 on junction box. Observe detected transmitter output waveform on AN/USM-105A for evidence of distortion. Connect output of HP-420B to ME-6C/U. Note audio output reference voltage of detected transmitter output as indicated on ME-6C/U and mic input closed circuit voltage as indicated on TS-505/U. Vary frequency of TS-382B/U from 300 Hz to 20 kHz maintaining reference mic input closed circuit voltage as indicated on TS-505/U. Measure the change of detected transmitter output in decibels from 1000-Hz reference as indicated on ME-6C/U.		

Figure 5-19. Preventive Maintenance Test, SA11 (Sheet 2 of 2)

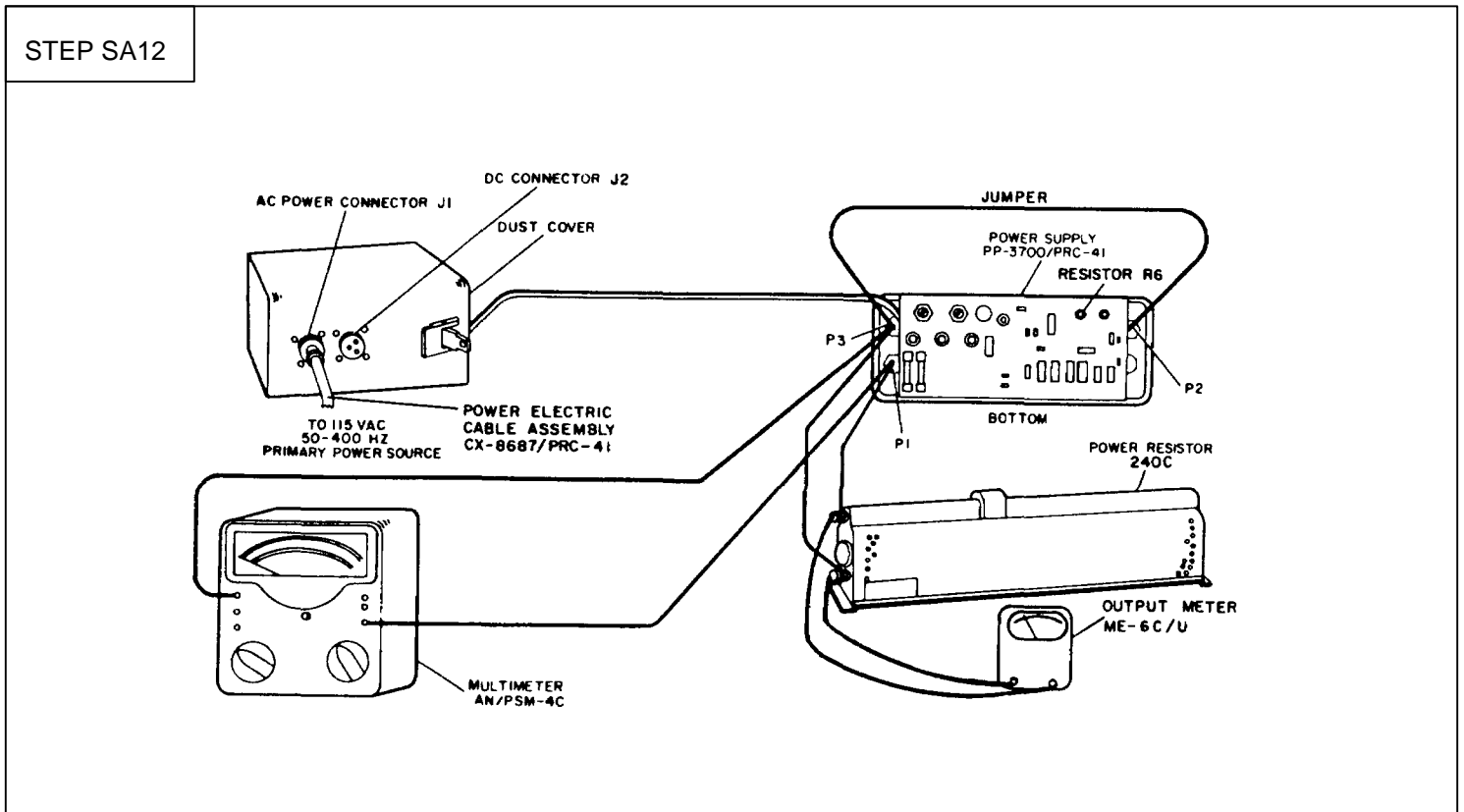

Figure 5-20. Preventive Maintenance Test, SA12 (Sheet 1 of 2)

			SA12
<p>OPERATING CONDITIONS: Connect Power Supply PP-3700/PRC-41 into test setup illustrated above.</p>			
STEP NO	ACTION REQUIRED	READ INDICATION ON	REFERENCE STANDARD
SA12	Measure 26.5-volt dc primary output under load conditions and ac ripple.	Multimeter AN/PSM-4A.	Power Supply PP-3700/PRC-41 primary dc output voltage shall be 26.5 volts dc across an 8-ohm load. Ac ripple shall not exceed 10 millivolts.
<p>PROCEDURE: Set Power Supply PP-3700/PRC-41 on test bench with side which clamps to rear of Radio Receiver-Transmitter RT-695A/PRC-41 upward. Loosen two captive screws in top plate, and remove main chassis from dust cover. Connect Power Electric Cable Assembly CX-8687/PRC-41 between dust cover connector J1 and 115-volt, 50- to 400-Hz primary power source. Adjust power resistor 240C for 8 ohms, and connect between P1 and P3. Connect AN/PSM-4A to PP-3700/PRC-41, positive lead to P1, negative lead to P3. Connect output meter ME-6C/U across power resistor 240C. Connect a jumper between P3 and P2. If measured output voltage as indicated on AN/PSM-4C is not 26.5 volts dc but is less than 30 volts dc and greater than 24 volts dc, adjust variable resistor R6 on PP-3700/PRC-41 to 26.5-volt dc output.</p>			

Figure 5-20. Preventive Maintenance Test, SA12 (Sheet 2 of 2)

### 5-3. TUNING AND ADJUSTMENT

a. GENERAL. - The following paragraphs contain alignment and adjustment procedures necessary to maintain optimum equipment performance. When performing overall alignment of the equipment, procedures must be performed in the order in which they occur in the following paragraphs. Before attempting alignment, read the complete alignment procedure carefully to become familiar with the steps involved. Do not attempt alignment of equipment as a substitute for trouble isolation.

#### CAUTION

Retracking should be performed only when it has been established that misalignment (mistracking) is the cause of abnormal operation.

(1) TEST EQUIPMENT. - Each align mentor adjustment procedure lists the test equipment required to perform that procedure.

(2) SPECIAL TOOLS AND CABLES. - The special tools supplied with Radio Set Accessory Kit MK-706/PRC-41 are listed in table 1-5 and illustrated in figure 1-13. The special cables supplied with MK-706/PRC-41 are listed in table 1-4 and illustrated in figure 1-12. These special tools and cables are required for the performance of alignment and adjustment procedures.

(3) PRELIMINARY TEST SETUP. - Refer to figure 5-21. Remove Receiver-Transmitter Case CY3884/PRC-41 from Radio Receiver-Transmitter RT-695A/PRC-41, and connect the dc maintenance adapter to the rear of RT-694A/PRC-41. Connect Power Electric Cable Assembly CX-8687/PRC-41 between Power Supply PP-3700/PRC-41 and 115-volt 50- to 400-Hz primary source. Connect Power Electric Cable Assembly CX-8686/PRC-41 between PP-3700/PRC-41 and the dc maintenance adapter. Connect junction box (figures 5-1 and 5-2) to KY-38 connector 1A9J14 on RT-695A/PRC-41. Connect Output Power Meter ME-2/U to normal audio output jack on junction box to provide required load for audio output circuits. Before performing alignment procedures, turn on equipment, and adjust frequency selector knobs for 225.0 MHz. (For removal of the 1st and 2nd if amplifier module, set the frequency selector knobs to 229.9 MHz.) Set OFF-T/R-T/R/G-DIAL LIGHT switch to OFF, and remove spectrum generator, 1st and 2nd if amplifier, and rf and power amplifier modules according to procedures of paragraph 5-4b. Check position of the couplers on main chassis to see that they are in the relative positions shown in figure 5-22. If the main chassis couplers are properly

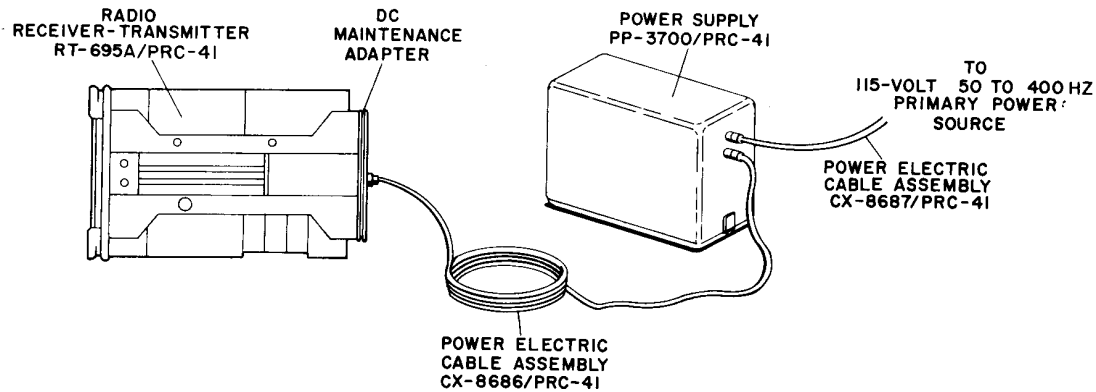

Figure 5-21. Radio Receiver-Transmitter RT-695A/PRC-41, Standard Test Bench Setup positioned, replace these modules according to module replacement procedures of paragraph 5-4g.

b. ALIGNMENT OF HIGH- AND LOW-FREQUENCY OSCILLATORS OF 1ST AND 2ND IF AMPLIFIER MODULE.

(1) TEST EQUIPMENT REQUIRED.

- (a) Electronic Multimeter TS-505/U.
- (b) Output Power Meter ME-2/U.

(2) ALIGNMENT SETUP.

- (a) Perform preliminary test setup procedure of paragraph 5-3a(3).
- (b) Set frequency selector knobs on RT-695A/PRC-41 to 329.0 MHz.
- (c) Connect TS- 505/U to test jack 1A2J1.
- (d) Set OFF-T/R-T/R/G-DIAL LIGHT switch to T/R, and allow 10 minutes warmup.

(3) PROCEDURE.

- (a) Adjust the 26.1-high-frequency oscillator slug (located on top of 1 stand 2nd if amplifier module) for maximum indication on TS- 505/U approximately -0.7 volt dc.
- (b) Change frequency selector knobs on RT-695A/PRC-41 to 328.0 MHz, and adjust 25.1-high-frequency oscillator slug as described for adjustment of 26.1-high-frequency oscillator slug in (a).
- (c) Adjust 24.1-high-frequency oscillator slug with frequency selector knobs set to 327.0 MHz as in (a).
- (d) Adjust 23.1-high-frequency oscillator slug with frequency selector knobs set to 326.0 MHz as in (a).
- (e) Adjust the 22.1-high-frequency oscillator slug with frequency selector knobs set to 325.0 MHz as in (a).
- (f) Adjust 21.1-high-frequency oscillator slug with frequency selector knobs set to 324.0 MHz as in (a).
- (g) Adjust 20.1-high-frequency oscillator slug with frequency selector knobs set to 323.0 MHz as in (a).
- (h) Adjust 19.1-high-frequency oscillator slug with frequency selector knobs set to 322.0 MHz as in (a).
- (i) Adjust 18.1-high-frequency oscillator slug with frequency selector knobs set to 321.0 MHz as in (a).
- (j) Adjust 17.1-high-frequency oscillator slug with frequency selector knobs set to 320.0 MHz as in (a).
- (k) Switch back through range of 1-MHz frequency selector knob to 329.0 MHz, and observe that T S- 505/U indicates approximately - 0.25 to - 1.5 volts on each 1-MHz position between 329.0 and 320.0 MHz.
- (l) Connect TS- 505/U to test jack 1A2J2, and measure approximately 2.5 volts for each setting of 10th-MHz frequency selector knob. This indicates that low-frequency oscillator is functioning properly. If indication is not obtained, refer to applicable troubleshooting procedures of section 4.

c. ALIGNMENT OF 1ST AND 2ND IF AMPLIFIER STAGES OF 1ST AND 2ND IF AMPLIFIER MODULE.

(1) TEST EQUIPMENT REQUIRED.

- (a) Electronic Multimeter TS- 505/U.
- (b) Signal Generator AN/USM-44A.
- (c) Oscilloscope AN/USM-105A.
- (d) Output Power Meter ME-2/U.

(2) ALIGNMENT SETUP.

- (a) Perform preliminary test setup procedure of paragraph 5-3a(3).
- (b) Connect AN/USM-105A to normal audio output jack on junction box as an aid in tuning signal generator to desired frequency and as monitor during alignment process.
- (c) Set frequency selector knobs on Radio Receiver-Transmitter RT-695A/PRC-41 to 329.0 MHz.
- (d) Connect TS-505/U to avc test jack 1A3J1.

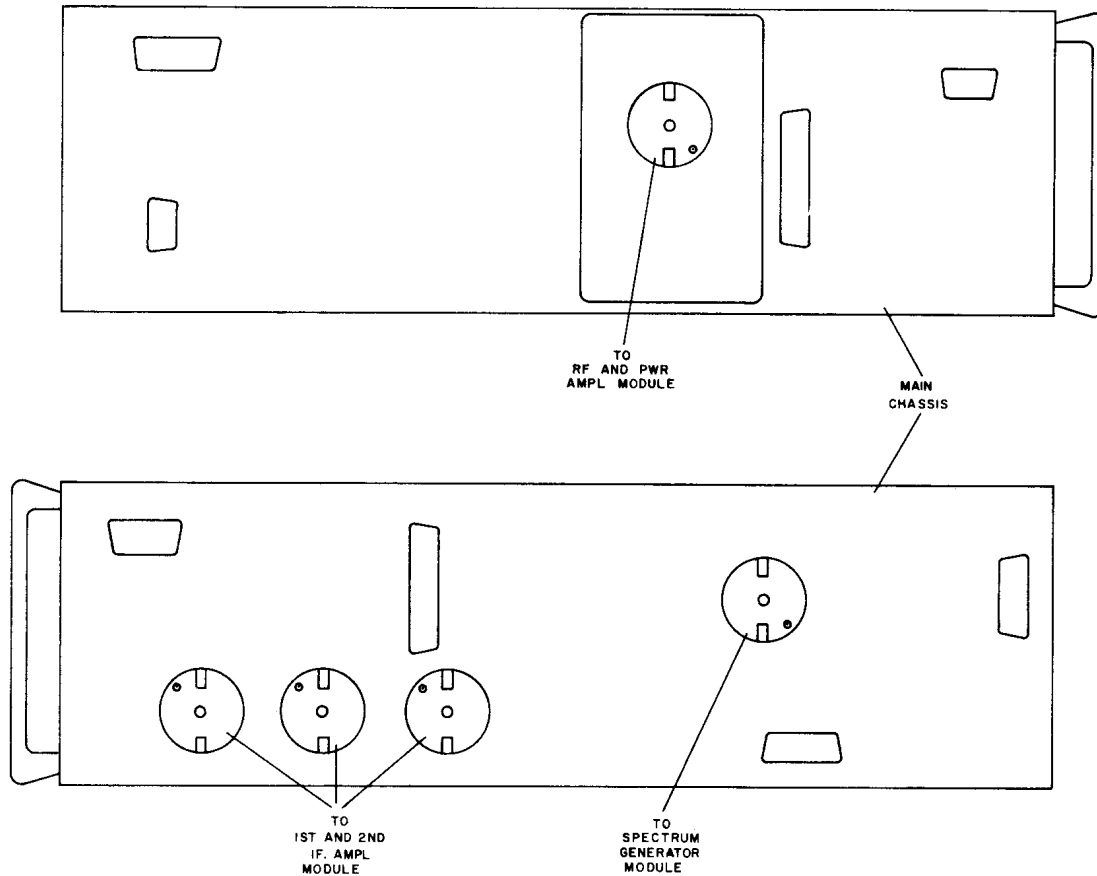

Figure 5-22. Main Chassis Couplers in the 225-MHz Position

(3) PROCEDURE.

- (a) Connect AN/USM-44A to input of if module by removing plug 1A9P2 from jack 1A9J17, connecting BNC-to-Conhex adapter A1 to 1A9P2, and connecting AN/USM-44A to BNC-to-Conhexadap-ter. Set AN/USM-44A for 29.0 MHz modulated 30 percent at 1000 Hz.
- (b) Increase output level of AN/USM-44A until signal can be tuned in by varying AN/USM-44A frequency slightly around 29.0 MHz. When AN/ USM-44A has been tuned to exactly 29.0 MHz, as indicated by maximum indication on TS505/U, maintain AN/USM-44A output at a minimum level to provide a usable signal on Oscilloscope AN/USM-105A.
- (c) Set OFF-T/R-T/R/G-DIAL LIGHT switch to T/R. Allow 10 minutes warmup.
- (d) Adjust trimmer capacitors C2, C5, C8, C12, C15, and C20 for maximum indication on TS- 505/U.
- (e) Set frequency selector knobs to 321.0 MHz. Repeat step (b), except set AN/USM-44A to 21.0 MHz, and adjust inductor slugs L1, L2, L3, L4, L5, and L6 for maximum indication on the TS-505/U.
- (f) Repeat steps (d) and (e) until no further improvement is obtained.
- (g) Set frequency selector knobs on RT-695A/PRC-51 to 329.9 MHz.
- (h) Set AN/USM-44A for 29.9 MHz modulated 30 percent with 1000 Hz.
- (i) Repeat step (b), except vary AN/ USM-44A frequency slightly about 29.9 MHz.
- (j) Adjust inductors L20, L22, and L24 for maximum indication on TS- 505/U.
- (k) Set frequency selector knobs on RT-695A/PRC-51 to 329.0 MHz.
- (l) Set AN/USM-44A for 29.0 MHz mod-ulated 30 percent with 1000 Hz.
- (m) Repeat step (b).
- (n) Adjust inductors L19, L21, and L23 for maximum indication on TS-505/U.
- (o) Repeat steps (g) through (n) above until no further improvement is observed. A good signal should be received with 10-microvolt or less output from AN/USM-44A.
- (p) Remove AN/USM-44A, and reconnect plug 1A9P2, to jack 1A9J17.
- (q) Remove modulator module from main chassis according to removal procedure, paragraph 5-4b, in order to remove B+ voltage from final stages. This prevents damage to final stages if they are not properly tuned.

(r) Connect TS-505/U to test jack 1A2J3. Set frequency selector knobs on RT-695A/PRC-51 to 329.9 MHz.

(s) Close switch S1 on junction box and adjust capacitors 1A2C33 and 1A2C20 for maximum negative indication on TS- 505/U.

(t) Open switch S1 on junction box and replace modulator module according to replacement procedure, paragraph 5-4g.

d. ALIGNMENT OF SPECTRUM GENERATOR MODULE.

(1) TEST EQUIPMENT REQUIRED.

- (a) Electronic Multimeter TS-505/U.
- (b) Frequency Counter AN/USM-122.
- (c) Electronic Frequency Converter CV-394/USA- 5.
- (d) Transfer Oscillator MC- 102/USM-73.
- (e) Output Power Meter ME-2/U.

(2) ALIGNMENT SETUP.

- (a) Perform preliminary test setup procedure of paragraph 5-3a(3).
- (b) Set frequency selector knobs on Radio Receiver-Transmitter RT-695A/PRC-41 to 399.9 MHz.
- (c) Remove red wire from collector lead of transistor 2A9Q1 on rear plate of main chassis, remove 12 cross-recessed screws attaching rear main chassis plate, and dress this plate clear of rear of main chassis.

(d) Loosen four captive screws on spectrum generator module, and remove module from main chassis. Be careful not to turn drive coupler on module. Remove module end cover having access holes for trimmer capacitors C10, C15, and C20 by removing eight cover screws. Replace spectrum generator module on main chassis according to replacement procedure, paragraph 5-4g.

(e) Remove plug 1A9P3 from jack 1A9J15 on transmit-receive coaxial switch. Connect CM-102/USM-73 to plug 1A9P3 using Conhex-to-BNC coaxial connector adapter A1.

(f) Set CV-394/USA- 5 in AN/USM- 122. Connect frequency meter output of CM-102/USM-73 to input jacks of CV-394/USA-5.

(g) Connect TS-505/U to test jack 1A5J1 on spectrum generator module.

(h) Set OFF-T/R-T/R/G-DIAL LIGHT switch to T/R, and allow 10 minutes warmup.

(3) PROCEDURE

(a) Adjust oscillator tuning slug for maximum indication on TS-505/U. (Oscillator tuning slug is accessible through top of spectrum generator module.) Check spectrum generator output frequency with AN/USM-122. Readjust oscillator tuning slug to produce an output frequency 2.5 to 5.0 kHz lower than nominal spectrum generator output frequency as listed in figure 4-11.

(b) Repeat step (a) for each 10-MHz increment through 229.9 MHz.

(c) Connect multimeter to test jack 1A5J2 on spectrum generator module, and rotate 10-MHz frequency selector knob throughout its range. Observe indication on TS-505/U to determine that a negative indication is obtained at all positions of frequency selector knob.

(d) Disconnect plug 1A9P3 from CM-102/USM-73, and reconnect it to jack 1A9J15.

(e) Adjust trimmer capacitors C 10, C15, and C20 for maximum negative indication on TS- 505/U.

(f) Set frequency selector knobs to 389.9 MHz. Refer to figure 5-23. Bend rotor blade segment which has just come into reach with stator on tuned circuits Z 1, Z2, and Z3 to obtain maximum indication on TS-505/U.

Note

All adjustment tabs are coded with a dot of paint as specified in the applicable tuning capacitor rotor tab illustration. The tab to be adjusted is identified further as the one partially meshed.

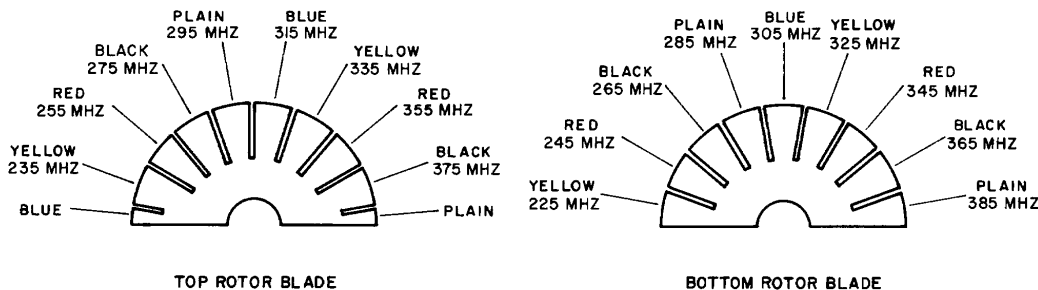

Figure 5-23. Spectrum Generator Module, Tuning Capacitor Rotor Tab Z1, Z2, Z3, Adjustment Diagram



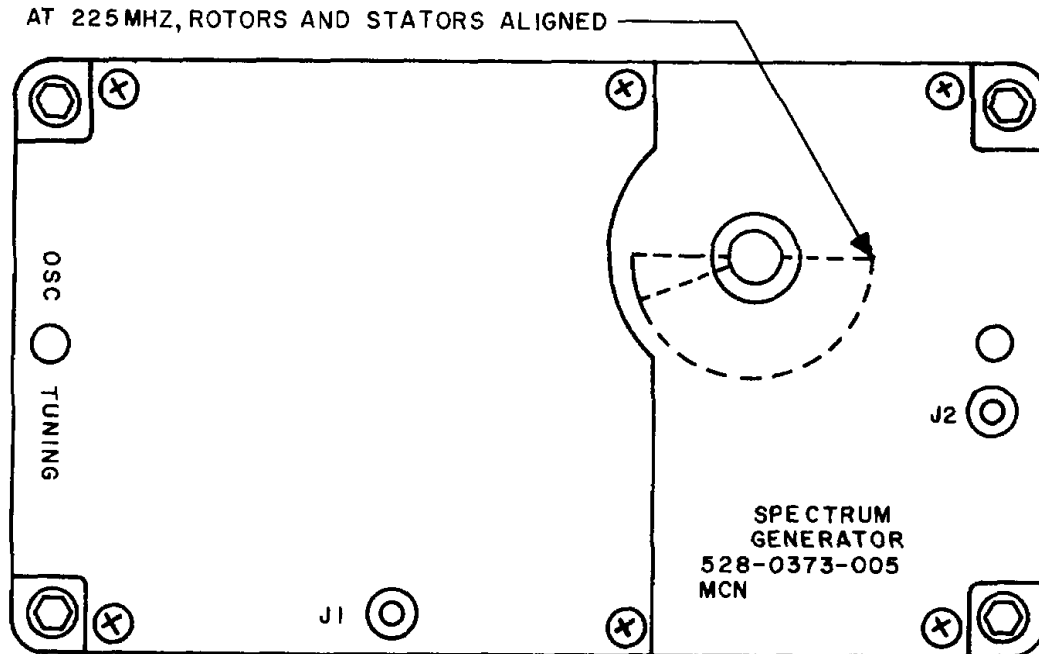

Figure 5-24. Spectrum Generator Module, Rotor-Stator Coincidence at 225 MHz

**CAUTION**

Never bend tabs out beyond a 30-degree angle. Excessive inward bending will cause tab to short against the stator. If a tuned circuit is far from resonance, it may be caused by circuit discontinuity. If this occurs, check inductance arm contacts and inductance rings for proper contact.

- (g) Set frequency selector knobs to 379.9 MHz. Bend rotor segment which has come into mesh with stator on tuned circuits Z1, Z2, and Z3 to obtain maximum indication on TS-505/U.
- (h) Repeat step (g) above for each 10-MHz increment to 229.9 MHz inclusive. Refer to figure 5-24.
- (i) Repeat steps (e) through (h) until no further improvement is obtained.
- (j) Repeat steps (a) and (b).

**Note**

The configuration of the tabs after adjustment should be a smooth contour with no sharp discontinuities.

Rechannel the equipment after each tab is bent to remove any backlash of the gears.

(k) Remove spectrum generator module, replace end cover, and reinstall module on main chassis according to replacement procedure, paragraph 5-4g. Position rear plate in place on main chassis, and secure with 12 cross-recessed screws. Resolder red wire to transistor 1A9Q2 collector lead.

**e. ALIGNMENT OF RF AND POWER AMPLIFIER MODULE.**

**(1) TEST EQUIPMENT REQUIRED.**

- (a) Electronic Multimeter TS-505/U.
- (b) RF Wattmeter AN/URM-43A.
- (c) Output Power Meter ME-2/U.

**(2) ALIGNMENT SETUP.**

- (a) Perform preliminary test setup procedure of paragraph 5-3a(3).
- (b) Connect AN/URM-43A to antenna connector 1A9J28 on front panel of Radio Receiver-Transmitter RT-695A/PRC-41.
- (c) Connect TS-505/U to V5 GRID test jack 1A8J8 on rf and power amplifier module 1A8.
- (d) Connect junction box (figures 5- 1 and 5-2) to K4-38 connector 1A9J14 on front panel of RT-695A/PRC-51.
- (e) Loosen two captive screws on guard receiver module 1A7, and remove module from main chassis.
- (f) Loosen four captive screws on dc power supply module 1A1, and remove module from main chassis.

Connect this module to main chassis using extension cable W5.

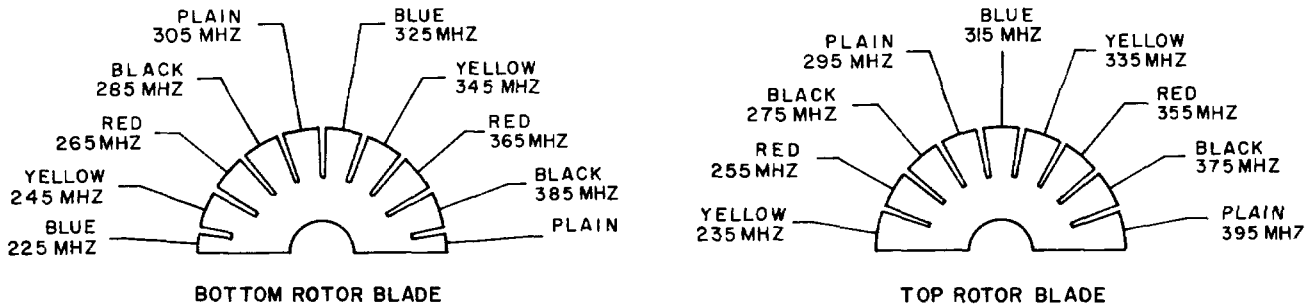

Figure 5-25. RF and Power Amplifier Module, Tuning Capacitor Rotor Tab Z1, Z2, and Z3, Adjustment Diagram

(g) Set OFF-T/R-T/R/G-DIAL LIGHT switch to T/R, and allow 10 minutes warmup. Set frequency selector knobs for 399.9 MHz.

(3) PROCEDURE.

- (a) Close switch S1 on junction box.
- (b) Adjust trimmer capacitors C7, C12 and C18 for a maximum negative indication on TS- 505/U.
- (c) Adjust trimmer capacitors C21 and C27 for a maximum indication on AN/URM-43C.
- (d) Set frequency selector knobs for 395.0 MHz.
- (e) Bend rotor blade segment which has just come into mesh with stator on tuned circuits Z1, Z2, and Z3 for a maximum negative indication on TS-505/U (figure 5-25).
- (f) Bend rotor blade segment which has just come into mesh with stator on tuned circuits Z4 and Z5 for a maximum indication on AN/URM-43C (figures 5-26 and 5-27).
- (g) Repeat rotor tab bending on Z1 through Z5 for each 10-MHz increment of frequency selector knobs to 225.0 MHz.

Note

All adjustment tabs are coded with a dot of paint as specified in the applicable tuning capacitor rotor tab illustration. The tab to be adjusted is identified further as the one partially meshed, and the sequence will alternate from one side of stator to the other.

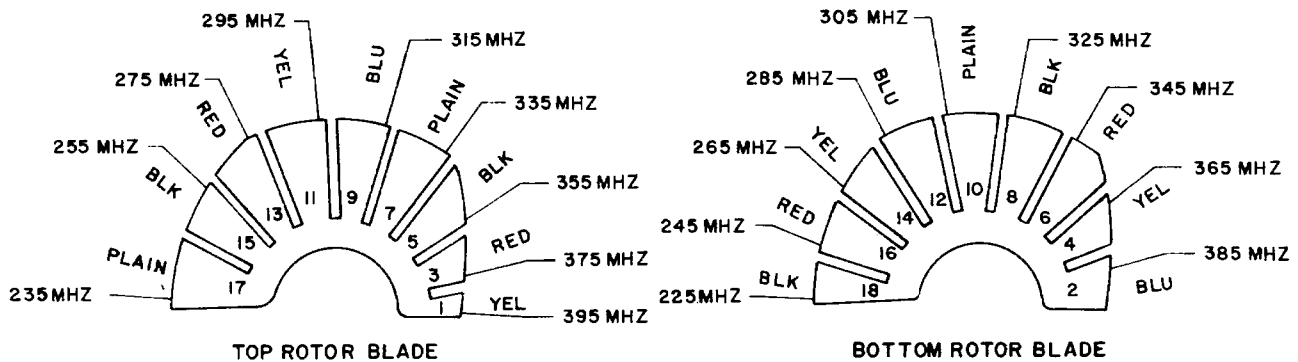

Figure 5-26. RF and Power Amplifier Module, Tuning Capacitor Rotor Tab Z1, Z4, and Z5, Adjustment Diagram

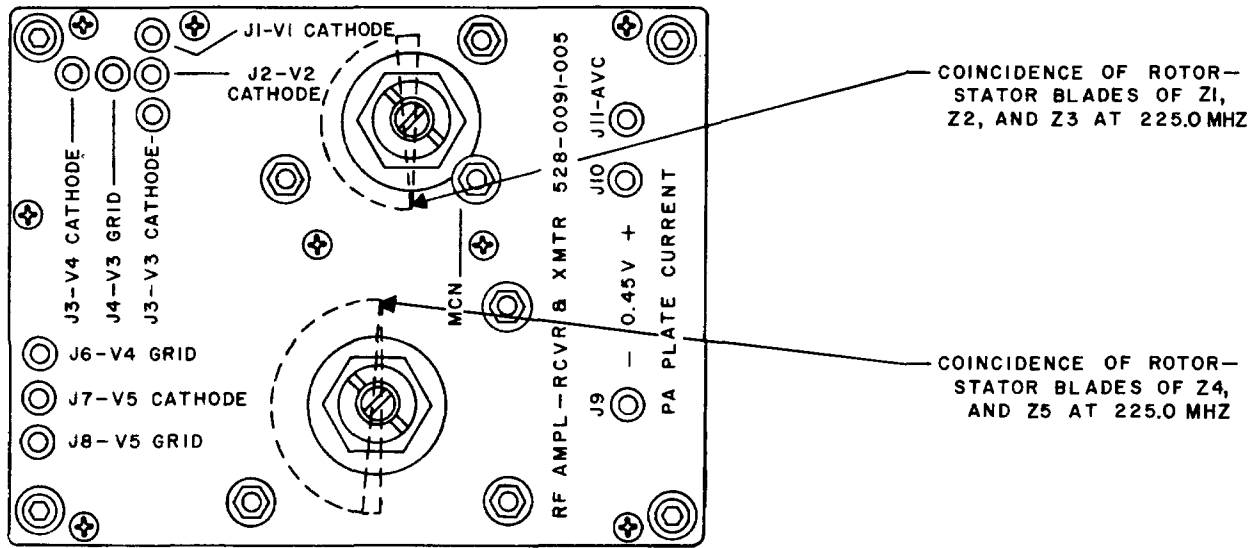

Figure 5-27. RF and Power Amplifier Module, Rotor-Stator Coincidence at 225 MHz

**CAUTION**

An insulated tool must be used for bending rotor tabs. Tuned circuits Z4 and Z5 are at 180 volts dc. Never bend tabs out beyond a 30-degree angle. Excessive inward bending will cause tab to short against the stator. If a tuned circuit is far from resonance, it may be caused by a circuit discontinuity. If this occurs, check inductance arm contacts and inductance rings for proper contact. Occasionally open switch S1 on junction box during procedure to prevent exceeding normal operating temperature of RT-695A/PRC-41.

(h) Repeat steps (b) through (g) until no further improvement is obtained.

**Note**

The configuration of the tabs after adjustment should be a smooth contour with no sharp discontinuities. Rechannel the equipment after each tab is bent to remove any backlash of the gears.

(i) Rotate 10-MHz frequency control knob throughout its range. Observe transmitter rf power output indication on AN/URM-43C. If satisfactory rf power output curve is obtained, replace guard receiver module 1A7 and dc power supply module 1A1 on main chassis. If satisfactory rf power output curve is not obtained, proceed to step (j).

(j) Remove rf and power amplifier module end cover having access holes for capacitors C7, C12, C18, C21, and C27 by removing eight cover screws.

(k) Adjust capacitors C27 and C30 alternately until optimum setting of each is determined to obtain maximum indication on AN/URM-43C over frequency range of 225.0 to 399.9 MHz.

(l) Replace end cover on rf and power amplifier module.

(m) Replace guard receiver module 1A7 and dc power supply module 1A1 on main chassis.

**f. ALIGNMENT OF GUARD RECEIVER MODULE.**

**(1) TEST EQUIPMENT REQUIRED.**

- (a) Electronic Multimeter TS-505/U.
- (b) Signal Generator AN/USM-44A.
- (c) Oscilloscope AN/USM-105A.
- (d) Output Power Meter ME-2/U.

**(2) ALIGNMENT SETUP.**

- (a) Perform preliminary test setup procedure of paragraph 5-3a(3).

- (b) Connect AN/USM-105A to NORMAL AUDIO OUTPUT jack on junction box.
  - (c) Loosen two captive screws on guard receiver module 1A7, and remove module from main chassis. Remove side cover from guard receiver module exposing transistors Q1 through Q5 and associated circuits.
  - (d) Connect AN/USM-44A through a 10-pF capacitor to junction point of base number 1 of transistor 1A7Q5, resistors R16 and R17, and capacitor C67 all located on TB2. Refer to figures 5-46, 5-47, and 5-48. Set AN/USM-44A to 20.55 MHz, modulated 30 percent with 1000 Hz.
  - (e) Connect guard receiver module to main chassis using extension cable W3.
  - (f) Connect TS-505/U to test jack 1A7J2 on guard receiver module.
  - (g) Set OFF-T/R-T/R/G-DIAL LIGHT switch to T/R/G, and allow 10 minutes warmup. Set SQUELCH control on front panel full clockwise.
  - (h) Turn SQUELCH resistor 1A7R46 in guard receiver full clockwise.
- (3) PROCEDURE.
- (a) Increase output of AN/USM-44A until signal appears on AN/USM-105A.
  - (b) Adjust inductors L15, L14, L13, L12, L16, and L11 for maximum indication on TS-505/U. Repeat sequence until no further improvement is obtained.

Note

Maintain output of AN/USM-44A at minimum level which gives a usable indication on Oscilloscope AN/USM-105A throughout the tuning process.

- (c) Adjust AN/USM-44A for 20.57 MHz, and readjust L16 and L17 for maximum indication on TS-505/U.
  - (d) Disconnect AN/USM-44A and 10-pF capacitor from base number 1 of transistor 1A7Q5. Replace side cover on guard receiver module, and replace module on main chassis.
  - (e) Remove TS-505/U from test jack 1A7J2, and connect to test jack 1A7J1.
  - (f) Adjust inductor L10 for maximum negative indication on TS-505/U (approximately -2.0 volts). With inductor L10 not tuned, indication will be zero.
  - (g) Connect AN/USM-44A to antenna connector 1A9J28 on front panel of RT-695A/PRC-41.
  - (h) Connect TS-505/U to avc test jack 1A7J2 on guard receiver module.
  - (i) Tune AN/USM-44A to 243.0 MHz, modulated 30 percent with 1000 Hz by adjusting output frequency about 243.0 MHz until maximum indication is obtained on TS-505/U.
  - (j) Adjust capacitor C22 and inductor L6 for maximum indication on TS-505/U.
  - (k) Adjust capacitors C16, C12, C6, and C1 for maximum indication on TS-505/U.
  - (l) Repeat steps (j) and (k) until no further improvement is obtained.
  - (m) Remove modulation from AN/USM44A, and readjust capacitor C1 for minimum indication on ME-2/U.
- g. FINAL ADJUSTMENTS.
- (1) GENERAL. - After the foregoing alignment procedures have been completed, it is necessary to make the following final adjustments.
- (a) 3RD IF AND SQUELCH MODULE. Make final adjustments to the 3rd if and squelch module as follows:
    1. Set frequency selector knobs on RT-695A/PRC-41 to 304.7 MHz.
    2. Connect Electronic Multimeter TS 505/U to 1A3J1 on 3rd IF and squelch module 1A3.
    3. Connect Output Power Meter ME 2/U and Oscilloscope AN/USM-105A to NORMAL AUDIO OUTPUT jack on junction box. Set ME-2/U to provide 300-ohm load for audio module.
    4. Connect Signal Generator AN/USM-44A to antenna connector 1A9J28 on front panel of RT-695A/PRC-41, and tune AN/USM-44A to 304.7 MHz by varying output frequency about 304.7 MHz until maximum indication is observed on TS-505/U. Increase AN/USM-44A output to 30 microvolts modulated 30 percent with 1000 Hz.
    5. Disconnect TS-505/U from 1A3J1, and connect to 1A8J11 on rf and power amplifier module 1A8. Adjust potentiometer 1A3R1 until voltage begins to rise (approximately 0.1 volt dc) as indicated on TS-505/U (low dc voltage scale).
    6. Increase AN/USM-44A output level to 1000 microvolts, and adjust modulation to 55 percent at 1000 Hz.
    7. Adjust potentiometer 1A3R26 until signal begins to clip as indicated on AN/USM105A.
    8. Decrease AN/USM-44A modulation to 30 percent at 1000 Hz.
    9. Adjust potentiometer 1A4R20 for 50 milliwatts as indicated on ME-2/U.
    10. Decrease AN/USM-44A output level to 20 microvolts. Adjust SQUELCH control 1A9R5 fully clockwise. Adjust 1A3R46 until squelch breaks (audio signal appears on AN/USM-105A).
  - (b) MODULATOR MODULE. - Make final adjustments to the modulator module as follows:
    1. Connect AN/URM-43C to antenna connector 1A9J28 on front panel of RT-695A/PRC-41.
    2. Connect AN/USM-105A to test jack 1A6J2 on modulator module.
    3. Connect TS-382B/U to MIC INPUT jack on junction box. Set TS-382B/U for 1000 Hz.
    4. Connect TS-505/U to MIC INPUT (open circuit) jack on junction box. Adjust output of TS-382B/U to indicate 0.7 volt on TS-505/U.
    5. Close switches S1 and S2 on junction box.

6. Adjust potentiometer 1A6R2 until signal on AN/USM-105A shows evidence of clipping.
7. Open switches S1 and S2 on junction box.
- (c) **GUARD RECEIVER MODULE.** -Make final adjustments to the guard receiver module as follows:
  1. Connect TS-505/U to test jack 1A7J2 on guard receiver module. Connect AN/USM-105A to normal audio output jack on junction box.
  2. Connect AN/USM-44A to antenna connector 1A9J28 on front panel of RT-695A/PRC-41. Set OFF-T/R-T/R/G-DIAL LIGHT switch to T/R/G.
  3. Tune AN/USM-44A to 243.0 MHz by varying output frequency about 243.0-MHz until maximum indication is observed on TS-505/U.
  4. Adjust squelch resistor 1A7R46 in guard receiver module counterclockwise until guard receiver module is squelched off, and signal disappears on AN/USM-105A with AN/USM-44A set at 2-uV input.
  5. Set AN/USM-44A to 243.0 MHz, 1000 microvolts, modulated 30 percent, and adjust 1A4R19 on audio amplifier module to indicate 50 milliwatts on ME-2/U.
  6. Set frequency controls main receiver to 304.7 MHz, and set AN/USM-44A to 304.7 MHz, modulated 30 percent, with 1000-microvolt output, and readjust 1A4R20 on audio amplifier module to indicate 50 milliwatts on ME-2/U.
  7. Repeat 5-3g(1)(c)5 and 5-3g(1) (c)6 until 50 milliwatts is obtained on both guard receiver and main receiver.

#### **5-4. REPAIR.**

a. **REMOVAL, REPAIR, AND REPLACEMENT OF PARTS, MODULES, AND UNITS.** - This subsection contains removal, disassembly, repair, reassembly, and replacement information for modules and assemblies of Radio Receiver-Transmitter RT-695A/PRC-41. Remove Receiver-Transmitter Case CY-3884/PRC-41 from RT-695A/PRC-41 by loosening four captive screws at the rear of CY-3884/PRC-41. Removal of the CY-3884/PRC-41 case permits access to the modules of RT-695A/PRC-41. Repair procedures involve the isolation of a defective detail part by use of troubleshooting procedures of section 4, and removal and replacement of the defective detail part. Refer to paragraph 5-4c for disassembly procedures of the mechanical assemblies. Refer to paragraph 5-4e for reassembly procedures. All adjustments of this equipment are covered under paragraph 5-3.

b. **MODULE REMOVAL.** - All modules of RT-695A/PRC-41 may be removed by loosening the captive screws and lifting the module upward. Set frequency selector knobs on front panel of RT-695A/PRC-41 to 229.9 MHz before removing the 1st and 2nd if amplifier module. Set frequency selector knobs to 225.0 MHz before removing either spectrum generator or rf and power amplifier modules.

c. **DISASSEMBLY.** - A mechanical assembly must not be disassembled unless it has been determined to be necessary to correct a malfunction. Disassembly procedures must not be performed as a matter of exploratory trouble isolation. In most cases, trouble can be corrected by adjustment procedures and application of operational theory. If trouble is known to exist in a part or a small assembly of parts not readily accessible, use the disassembly instructions to provide a guide for complete disassembly. These instructions are not to infer that a module should be regularly disassembled, since disassembly will disturb factory alignment. Use disassembly procedures only to extent necessary to effect required overhaul. Disassembly is limited to removal of mechanical items such as gears, bearings, shafts, etc. Internal wiring, resistors, capacitors, or other electrical items are not removed unless such action is necessary for access to a part requiring overhaul. The module disassembly procedures make reference to exploded views which use reference designations for identifying detail parts and assemblies. While performing disassembly procedures, be careful to avoid excessive strain on internal connections and to prevent distortion of shafts and rotor assemblies. A wiring diagram should be drawn as an aid to reassembly before removal of any part requiring unsoldering of several wires. This diagram should show any color coding or markings of wires, and approximate location and identity of terminals to which they are connected. In cases where lacing is to be removed or where lead dress is important, this must also be shown.

#### **CAUTION**

Before removing matching or meshing parts, use a scribe or otherwise mark the relative positions of such parts to ensure correct reassembly.

(1) **1ST AND 2ND IF AMPLIFIER MODULE.**-Remove 1st and 2nd if amplifier module from main chassis of RT-695A/PRC-41 according to procedures of paragraph 5-4b. To disassemble 1st and 2nd if amplifier module (figures 5-28 and 5-75), perform the following:

(a) **Z1, Z2, AND Z3 SLUG RACK.** - To disassemble the Z1, Z2, and Z3 slug rack and gain access to the amplifier subassembly, refer to figure 5-75, and perform the following:

1. Remove thirteen 2-56x3/16-inch self-locking screws, and remove amplifier covers MP16 and MP17 from electrical equipment chassis MP39.
2. From bottom of right front corner of 1st and 2nd if amplifier module, remove a 2-56 x 1/8-inch screw and 2-56 nut, and remove captive screw H2.
3. Remove spring pin from cams MP12 and MP13. Remove shouldered shaft MP14,

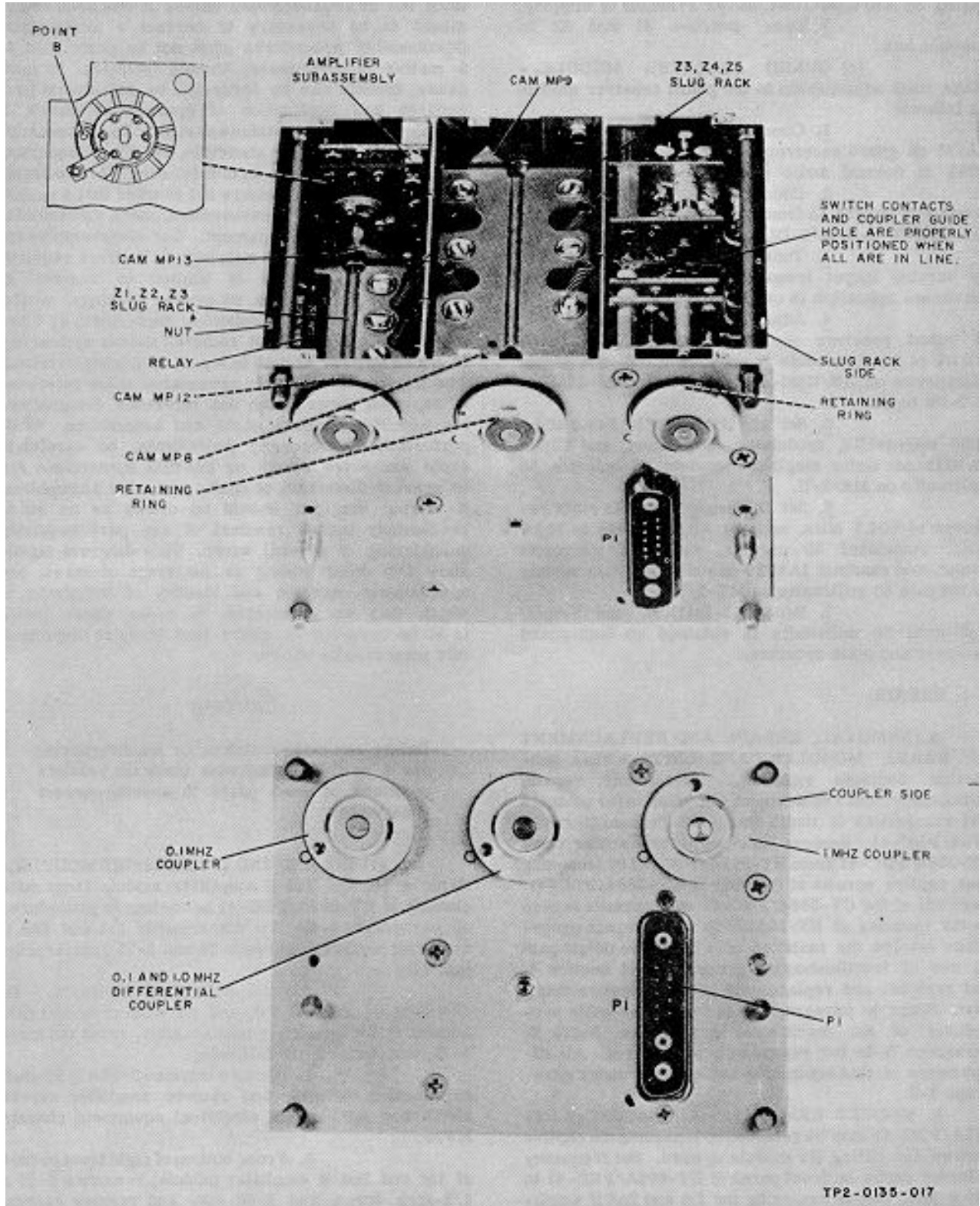

Figure 5-28. 1st and 2nd IF Amplifier Module, Switch and Cam Positioning Diagram

cams MP12 and MP13, and two flat washers H3. Remove Z1, Z2, and Z3 slug rack MP22.

4. Remove three 4-40 x 1/8-inch and one 4-40 x 1/4-inch screws from top of electrical equipment chassis MP39. Unsolder electrical connections at points A (figure 5-40) on wired bracket, coaxial lead and ground connection on amplifier subassembly, and remove two 2-56 x 1/4-inch screws to free relay K3. For further disassembly of amplifier subassembly, see figure 5-78.

(b) Z4, Z5, AND Z6 SLUG RACK. - To disassemble Z4, Z5, and Z6 slug rack, see figure 5-75 and perform the following:

1. Remove thirteen 2-56x3/16-inch self-locking screws, and remove amplifier covers MP16 and MP17 from electrical equipment chassis MP39.

2. Remove spring pin from cams MP8 and MP9.

3. Remove retaining ring from shouldered shaft MP11, two cams MP8 and MP9, and two flat washers H3. Remove Z4, Z5, and Z6 slug rack upward.

(c) OSCILLATOR AND SWITCHBOARD, AND RF COIL ASSEMBLIES. - To gain access to detail parts of either oscillator and switchboard assembly or rf coil assembly, remove amplifier cover MP16, remove retaining ring from shouldered shaft MP15, and remove shouldered shaft MP15 outward from electrical equipment chassis MP39. For further disassembly procedures, refer to figures 5-76 and 5-77. Refer to figure 5-75 for an exploded view of amplifier subassembly board number 1.

(2) RF AND POWER AMPLIFIER MODULE. - Remove rf and power amplifier module from main chassis of Radio Receiver-Transmitter RT-695A/PRC-41 according to paragraph 5-4b. To disassemble rf and power amplifier module, refer to figure 5-80, and perform the steps of either paragraph 5-4c(2)(a) or 5-4c(2)(b) as applicable.

(a) Z 1, Z2, AND Z3 TUNED CIRCUITS. - To disassemble Z1, Z2, and Z3 tuned circuits to gain access to a particular detail part, refer to figure 5-80, and perform the following:

1. Remove eight 2-56 x 1/8 inch cross-recessed screws, and remove side cover MP19. Remove plastic retaining ring MP1 and coupler MP5. Remove spring pin from shaft coupler MP4, and remove MP4 from gear and shaft MP22.

2. Remove two 6-32 x 1/2-inch cross-recessed screws from gearplate MP28, and remove gearplate MP28.

3. Gears MP41, -MP21, MP22, and MP23 may be removed as required from bottom plate MP33. (Scribe gear and shaft MP22 and gears MP23 and MP41 for reassembly reference.)

4. Loosen two setscrews in shaft collar MP6(1), and slide MP6(1) and ground spring MP42(1) clear of retaining ring next to bottom plate bearing. Remove retaining ring.

5. Loosen two setscrews in shaft collars MP6(2), and MP6(3), and MP6(4). Position rotor of tuned circuit Z3 so that it is completely unmeshed with its stator, and slide straight shaft MP14 outward from bottom plate MP33 far enough to gain access to retaining ring which normally rides against bearing MP2(2) in top plate. Remove retaining ring. Remove straight shaft MP14, and remove rotors and shaft collars from tuned circuits Z1 through Z3.

(b) Z4 AND Z5 TUNED CIRCUITS. - To disassemble Z4 and Z5 tuned circuits to gain access to a particular detail part, refer to figure 5-80, and perform the following:

1. Remove eight 2-56 x 1/8-inch cross-recessed screws, and remove side cover MP16. Remove retaining ring MP1 and coupler MP5. Remove spring pin from shaft coupler MP4 and remove MP4 from gear and shaft MP22..

2. Remove two 6-32 x 1/2-inch cross-recessed screws from gearplate MP28, and remove gearplate MP28.

3. Remove spring pin from gear MP23, and remove gear MP23 from shaft MP32. (Scribe gear and shaft MP22 and gears MP23 and MP41 for assembly reference.)

4. Remove spring pin from gear MP41, and remove gear MP41. Remove gears MP21 and MP22.

5. Remove four 2-57 x 3/8-inch self-locking screws at corners of bottom plate MP33 and one at location A. Remove six 2- 56 x 5/16 inch screws, nuts, and lockwashers from location B. Remove two 2- 56 x 3/8-inch screws securing plug P2; free plug P2. Remove two 2-56 x 3/16-inch screws, nuts, and lockwashers from connector P 1 and free connector P 1. Remove bottom plate MP33.

6. Loosen two setscrews in rotors MP29(1) and MP29(2). Loosen two setscrews in shaft collar MP6(5), and remove retaining ring (6). Remove capacitor shaft MP32.

(3) SPECTRUM GENERATOR MODULE. Remove spectrum generator module from main chassis of RT-695A/PRC-41 according to paragraph 5-4b. Disassemble spectrum generator module as required according to applicable paragraphs 5-4c(3)(a) through 5-4c(3)(c).

(a) CRYSTAL AND SWITCH SECTION S2. -To remove or gain access to a detail part in the crystal and switch S2 section of spectrum generator module, refer to figure 5-79, and perform the following:

1. Remove twenty-six 2-56 x 3/16 inch screws from side covers MP17 and MP18. Remove six 2-56 x 1/8-inch and five 2-56 x 3/16-inch screws from front cover MP19, and remove front cover MP19.

2. Remove four 4-40 x 1/4-inch and four 2-56 x 1/4-inch screws from crystal cover MP20. Unsolder test jack 1A5J1 from 100-kΩ resistor R3, and remove crystal cover MP20.

3. Remove thermal insulation MP35 from switch S2, and remove switch S2.

4. Remove 2-56 x 3/16-inch screw, lockwasher, and flat washer from end of straight shaft MP25. Remove switch rotor E5.

(b) COIL TURRET SECTION. - To remove or gain access to a detail part in the coil turret section of spectrum generator module, refer to figure 5-79, and perform the following:

1. Remove twenty-six 2-56 x 3/16 inch screws from side covers MP17 and MP18. Remove six 2-56 x 1/8-inch and five 2-56 x 3/16 inch screws from front cover MP19, and remove front cover MP19.

2. Remove plastic retaining ring MP1 and coupling MP9. Remove spring pin from shaft coupling MP6, and remove shaft coupling MP6. Remove retaining ring MP4.

3. Remove six 4-40 x 3/8-inch screws from mounting plate MP21. Remove two 2-56 x 3/8-inch screws, nuts, and lockwashers, securing connector P1, and free mounting plate MP21 from connector P1. Remove mounting plate MP21.

4. Loosen setscrews in shaft collar MP7, and remove gear MP13 and shaft collar MP7. Remove three 2-56 x 1/4-inch screws and coil assembly E13.

5. If it becomes necessary to replace straight shaft MP25, perform the disassembly procedures of paragraph 5-4c(3)(a) and preceding steps of this paragraph, remove retaining ring MP4, and remove straight shaft MP25.

(c) TUNING CIRCUIT SECTION. - To remove or gain access to a detail part in the tuning circuit section of spectrum generator module, refer to figure 5-79, and perform the following:

1. Remove twenty-six 2-56 x 3/16 inch screws from side covers MP17 and MP18, and remove side covers MP17 and MP18. Remove six 2-56 x 1/4-inch and two 2-56 x 1/8-inch screws from rear cover MP16, and remove rear cover MP16.

2. Remove plastic retaining ring MP1 and coupling MP9. Remove spring pin from shaft coupling MP6, and remove shaft coupling MP6. Remove retaining ring MP4.

3. Remove six 4-40 x 3/8-inch screws from mounting plate MP21. Remove two 2-56 x 3/8-inch screws, nuts, and lockwashers, securing connector P1 and free mounting plate MP21 from connector P1. Remove mounting plate MP21.

4. Remove hexnut H3 and bearing housing MP10 from top of spectrum generator module. Remove annular bearing MP2 and retaining ring MP5.

5. Loosen two setscrews on shaft collars MP11 in tuned circuit Z1 and MP7 in tuned circuits Z2 and Z3.

6. Pull straight shaft MP29 outward toward coupler side of spectrum generator module to clear tuned circuits Z1 through Z3 as required.

7. Remove three capacitor rotors E10 and grounding springs E3 and E4 as required.

(4) RADIO RECEIVER-TRANSMITTER RT-695A/PRC-41 MAIN CHASSIS. - Remove RT-695A/ PRC-41 modules from main chassis according to paragraph 5-4b. Disassemble main chassis of RT695A/PRC-41 as required according to the following procedures (figure 5-81).

(a) Remove five 6-32 x 5/16-inch screws at location B. and loosen one screw at location A on rear plate MP1.

(b) Remove five 6-32 x 5/16-inch screws at location D, and loosen one screw at location C on rear plate MP1.

(c) Remove four 6-32 x 1/4-inch screws at location E on frame MP4. Remove three 4-40 x 1/4-inch screws at location F on frame MP4.

(d) Remove four 6-32 x 1/4-inch screws at location J on frame MP3. Remove four 4-40 x 1/4-inch screws at location H on frame MP3.

(e) Loosen setscrews in control knobs O1 through O6 on front panel MP52 and remove control knobs O1 through O6.

(f) Remove locking nuts on connectors 1A9J14, 1A9J13, and 1A9J28 on front panel MP52 and free connectors 1A9J14, 1A9J13, and 1A9J28.

(g) Loosen locking nuts on controls, and free control shafts from front panel MP52.

(h) Carefully remove side frames MP3 and MP4 and rear plate MP1 from gear frame MP53 and front panel MP52.

(i) Remove four screws and lockwashers from gear frame MP53 at location K, and separate front panel MP52 from gear frame MP53.

(j) Remove four 2-56 x 3/16-inch screws from detent MP39, remove screw attaching spring MP77 and sleeve MP45, and remove detent MP39.

(k) Loosen screws in four coupler clamps MP48, and remove couplers MP49 and MP50, and two couplers MP51.

(l) Remove four spacer nuts MP74 at location M on gearplate MP30. Remove gearplate MP30 from gear frame MP53. At this point, access to remaining detail parts may be obtained as required.

d. REPAIR. - Repair procedures involve isolation of defective electrical parts by use of the troubleshooting procedures of section 4 and by inspection of mechanical parts and assemblies, removal and replacement of defective detail part, and the necessary synchronization and adjustment. Reassemble the disassembled mechanical assembly according to the applicable procedures of paragraph 5-4e. Synchronize the assembly according to paragraph 5-4f and make the necessary alignment according to applicable procedures of paragraph 5-3. Lubricate equipment as required according to paragraph 5-6.

e. REASSEMBLY.

(1) 1ST AND 2ND IF AMPLIFIER MODULE. To reassemble disassembled 1st and 2nd if amplifier module, refer to figure 5-75, and perform the steps of paragraphs 5-4f(1)(a) through 5-4f(1)(c) as required.



(a) Z1, Z2, AND Z3 SLUG RACK. - To reassemble the Z1, Z2, and Z3 slug rack and replace the amplifier subassembly, refer to figure 5-75, and perform the following:

1. Replace amplifier subassembly in place in electrical equipment chassis MP39 and secure by use of three 4-40 x 1/8-inch and one 4-40 x 1/4-inch screws. Solder electrical connections at points A (figure 5-40) on wired bracket, coaxial lead and ground connections on amplifier subassembly, and secure relay K3 with two 2-56 x 1/4-inch screws.
2. Set Z1, Z2, and Z3 slug rack MP22 in place on electrical equipment chassis MP39. Replace shaft end of shouldered shaft MP14 into bearing of electrical equipment chassis MP39, through cam MP12, flat washer H3, slug rack MP22, second flat washer H3, second cam MP13, through switches of amplifier subassembly, and into bearing of electrical equipment chassis MP39.
3. Set 1st and 2nd if amplifier module on maintenance bench so it is resting on wired bracket assembly and slug racks are upward. Rotate coupling MP10 so the guide pin hole is located over silk-screened circle on coupler side of electrical equipment chassis MP39. Rotor of rotary switch on amplifier subassembly should be making contact with its stator at point B (figure 5-28) and high point on cams MP12 and MP13 should be positioned downward. Replace spring pins in cams MP12 and MP13, and connect two helical springs MP6.
4. Replace captive screw H2 in top front position, and replace 2-56 x 1/4-inch screw and nut in bottom of right front corner of 1<sup>st</sup> and 2<sup>nd</sup> if amplifier module.
5. Replace amplifier side covers MP16 and MP17 and secure in place with thirteen 2-56 x 3/16-inch self-locking screws.

(b) Z4, Z5, AND Z6 SLUG RACK. - To reassemble Z4, Z5, and Z6 slug rack, refer to figure 5-75, and perform the following:

1. Set slug rack MP25 in place on electrical equipment chassis MP39.
2. Replace shaft end of shouldered shaft MP11 into bearing of electrical equipment chassis MP39, through cam MP8, flat washer H3, slug rack MP25, second flat washer H3, second cam MP9, and into bearing of electrical equipment chassis MP39.
3. Replace retaining ring in shouldered shaft MP11. Rotate coupling MP10 so the guide pin hole is located over silk-screened circle on coupler side of electrical equipment chassis MP39.
4. Rotate cams MP8 and MP9 so their flat sides are upward and to left, and the collar pinning holes match holes in shouldered shaft MP11. Replace spring pins in cams MP8 and MP9 and connect four helical springs MP6. Refer to figure 5-28.
5. Replace side covers MP16 and MP17, and secure in place with thirteen 2-56 x 3/16-inch screws.

(c) OSCILLATOR AND SWITCHBOARD, AND RF COIL ASSEMBLIES. - With the oscillator and switchboard, and rf coil assemblies in place on electrical equipment chassis MP39, replace the shaft of shouldered shaft MP15 into the bearing of chassis MP39. Replace the shaft of shouldered shaft MP15 through oscillator and switchboard assembly, rf coil assembly and into bearing of electrical equipment chassis MP39. With coupling MP 10 of shouldered shaft MP15 rotated so its guide pin hole is upward, electrical contacts of the rotary switches in oscillator and switchboard and rf coil assemblies should be upward and in line with the coupling MP10 guide pin hole (figure 5-28). Replace retaining ring on shouldered shaft MP15.

(2) RF AND POWER AMPLIFIER MODULE. - To reassemble the disassembled rf and power amplifier module, refer to figure 5-80, and perform the steps of paragraphs 5-4f(2)(a) through 5-4f(2)(b) as required.

(a) Z1, Z2, AND Z3 TUNED CIRCUITS.- To reassemble Z1, Z2, and Z3 tuned circuits, refer to figure 5-80, and perform the following:

1. Pass straight shaft MP14 through bottom plate MP33 at location C. Within tuned circuit Z 1, replace grounding spring MP42(1), grounding spring contact MP8(1), shaft collars MP6(1) and MP6(2), and shaft collar and rotor MP10(1) over straight shaft MP14.
2. Continue replacing rotors, grounding springs, shaft collars, etc. on straight shaft MP14 as MP14 is passed through tuned circuits Z2 and Z3.
3. Replace retaining rings (1 and 2), and pass shaft MP14 into bearing MP2(2). Replace 5/8-inch spring pin in straight shaft MP14. Rotate straight shaft MP14 fully clockwise so that 5/8-inch spring pin is stopped by stop pin in bottom plate MP33.
4. Position rotors in tuned circuits Z1 through Z3 so that they are in mesh with their stators and the flat edges of stators and rotors are in coincidence at their back side. Refer to figure 5-27. Tighten all shaft collars.
5. Replace gear and shaft MP22 in position so scribes made during disassembly are matched. Replace gears MP21, MP41, and MP23. Matching scribes made during disassembly are matched. Replace gearplate MP28, and secure in place with two 6-32 x 1/2-inch cross-recessed screws.
6. Replace shaft coupler MP4, and secure in place with spring pin. Replace coupler MP5, and secure in place with retaining ring MP1.

(b) Z4 AND Z5 TUNED CIRCUITS. - To reassemble Z4 and Z5 tuned circuits, refer to figure 5-80, and perform the following:

1. Carefully pass capacitor shaft MP32 through MP13. Replace rotor MP29(2), shaft collar MP6(5), grounding spring contact MP8(2), grounding spring E1, and retaining ring (6) on capacitor shaft MP32.
2. Replace rotor MP29(1), shaft cam MP24, grounding spring MP11(3), and retaining ring (5) on capacitor shaft MP32.
3. Replace bottom plate MP33 in position, and secure in place by replacing four

2-56 x 3/8-inch self-locking screws at corners and one at location A. Replace six 2-56 x 5/16-inch screws, nuts, and lockwashers at location B. Secure plug P2 in place with two 2-56 x 3/8-inch screws. Secure plug P1 in place by use of two 2-56 x 3/16-inch screws, nuts, and lockwashers.

4. Check to see that 5/8-inch spring pin in straight shaft MP14 is against its stop pin. Replace gear MP23 on capacitor shaft MP32, and secure in place with its spring pin.

5. Replace gearplate MP28 and secure in place with two 6-32 x 1/2-inch cross-recessed screws. Replace shaft coupler MP4, and secure in place with spring pin. Replace coupler MP5, and secure in place with retaining ring MP1.

(3) SPECTRUM GENERATOR MODULE. -To reassemble the disassembled spectrum generator module, refer to figure 5-79, and perform the applicable procedures of paragraphs 5-4f(3)(a) through 5-4f(3)(c).

(a) CRYSTAL AND SWITCH S2 SECTION. - To reassemble mechanical parts of crystal and switch S2 section, perform the following:

1. Replace switch rotor E5. Secure switch rotor E5 in place with 2-56 x 3/16-inch screw, lock-washer, and flat washer.

2. Position crystal and switch S2 section in place over switch rotor E5. Fit resistor R3 through proper hole in printed circuit switch S2.

3. Replace thermal insulation MP35 over crystals on switch section S2.

4. Replace crystal cover MP20 and secure with four 4-40 x 1/4-inch and four 2-56 x 1/4-inch screws; connect test jack 1A5J1 to 100-k  $\Omega$  resistor R3.

5. Check synchronization according to paragraph 5-4f, and make required adjustments. Replace side covers MP17 and MP18, and secure in place with twenty-six 2-56 x 3/16-inch screws. Replace cover MP19 and secure in place with six 2-56 x 1/8-inch and five 2-56 x 3/16-inch screws.

(b) COIL TURRET SECTION. - To reassemble mechanical parts of coil turret section, refer to figure 5-79, and perform the following:

1. If straight shaft MP25 and shaft collar MP26 were removed, replace straight shaft in bearing of chassis MP28. Replace retaining ring MP4 on straight shaft MP25. Reassemble crystal and switch S2 section in accordance with paragraph 5-4c(3)(a).

2. Replace coil assembly E13 over straight shaft MP25, and secure to shaft collar MP26 with three 2-56 x 1/4-inch screws. Replace shaft collar MP7 and gear MP13 on straight shaft MP25, and tighten setscrews in shaft collar MP7.

3. Replace mounting plate MP21 in position on spectrum generator module, and carefully fit gears MP14 located on mounting plate MP21 to gears MP13 and MP33. Position keying tab of grounding spring E11 in keying hole on mounting plate MP21. Secure mounting plate MP21 in place with six 4-40 x 3/8-inch screws.

4. Secure connector P1 to mounting plate MP21 with two 2-56 x 3/8-inch screws, nuts, lockwashers, and solder lugs.

5. Replace retaining ring MP4 on straight shaft MP25. Replace shaft coupling MP6 on straight shaft MP25, and secure in place with spring pin. Replace coupling MP9, and secure in place with plastic retaining ring MP1.

6. Check synchronization according to paragraph 5-4f and make required adjustments. Replace side covers MP17 and MP18, and secure in place with twenty-six 2-56 x 3/16-inch screws. Replace cover MP19, and secure in place with six screws 2-56 x 1/8-inch and five 2-56 x 3/16-inch screws.

(c) TUNING CIRCUIT SECTION. - To reassemble mechanical parts of tuning circuit section, refer to figure 5-79, and perform the following:

1. Replace straight shaft MP29 with gear MP33 into position in spectrum generator chassis MP30. In tuned circuits Z1, Z2, and/or Z3, replace capacitor rotors E10 and grounding springs E3 and E4 as required.

2. Replace retaining ring MP5 and bearing MP2 on retaining plate MP24 end of straight shaft MP29. Position keying tab of grounding spring E4 in keying hole on retaining plate MP24, and replace bearing housing MP10 over bearing MP2.

3. Replace hexnut MPH3 on bearing housing MP10 and tighten.

4. Replace grounding spring E11 on straight shaft MP29. Replace mounting plate MP21 in position on spectrum generator module, and carefully fit gear MP14 located on mounting plate MP21 to gears MP13 and MP33. Position keying tab of grounding spring E11 in keying hole on mounting plate MP21. Secure mounting plate MP21 in place with six 4-40 x 3/8-inch screws.

5. Secure connector P1 to mounting plate MP21 with two 2-56 x 3/8-inch screws, nuts, lockwashers, and solder lugs.

6. Replace retaining ring MP4 on straight shaft MP25. Replace shaft coupling MP6 on straight shaft MP25, and secure in place with spring pin. Replace coupling MP9, and secure in place with plastic retaining ring MP1.

7. Position and synchronize three capacitor rotors E10 according to paragraph 5-4f, and tighten setscrews in shaft collars MP7 and MP11. Replace side covers MP17 and MP18, and secure in place with twenty-six 2-56 x 3/16-inch screws. Replace rear cover MP16, and secure in place with six 2-56 x 1/4-inch and two 2-56 x 1/8-inch screws.

(4) RADIO RECEIVER-TRANSMITTER RT-695A/PRC-41 MAIN CHASSIS. -To reassemble the disassembled main chassis of RT-695A/PRC-41, refer to figure 5-81, and perform the following:

(a) Replace detail parts as required on gear frame MP53. Replace gearplate MP30 in position on gear frame MP53, and secure in place with four spacer nuts at location M.

(b) Replace four coupler clamps MP48 and couplers MP51, MP50, and MP49 on gearshaft

MP42, shaft MP84, shaft of differential MP71 and gearshaft MP40. Tighten coupler clamp screws.

(c) Replace detent MP39, and secure in place with four 2-56 x 3/16 screws and lockwashers. Replace spring MP77 over sleeve MP45, and secure with screws.

(d) Fit front panel MP52 to gear frame MP53, and secure with four screws and lockwashers at position K.

(e) Carefully fit side frames MP3 and MP4 and rear plate MP1 over gear frame MP53.

Reconnect required electrical connections, and fit front panel MP52 to control shafts and connectors of side frames MP3 and MP4 and gear frame MP53.

(f) Secure all control shafts and connectors that project through front panel MP52 with their applicable locking nuts. Secure side frames MP3 and MP4 to front panel MP52 by replacing eight 6-32 x 1/4-inch screws and lockwashers at positions E and J.

(g) Replace five 6-32 x 5/16-inch screws at location B, and tighten one screw at location A on rear plate MP1.

(h) Replace five 6-32 x 5/16-inch screws at location D, and tighten one screw at location C on rear plate MP1.

(i) Replace three 4-40 x 1/4-inch screws at location F on side frame MP4.

(j) Replace four 4-40 x 1/4-inch screws at location H on side frame MP3.

(k) Replace all control knobs in applicable positions, and tighten setscrews.

f. SYNCHRONIZATION.

(1) 1ST AND 2ND IF AMPLIFIER MODULE. The 1st and 2nd if amplifier module is synchronized during reassembly. Loss of synchronization or improper angular positioning of switch rotors or couplings is an indication of a defective detail part which must be located and replaced. Refer to figure 5-28 for correct synchronization of switch rotors, cams, and couplers. Subject 1st and 2nd if amplifier module to the trouble isolation procedures described in applicable portion of section 4.

(2) RF AND POWER AMPLIFIER MODULE. - Synchronize rf and power amplifier module as follows:

(a) Rotate coupler on rf and power amplifier module so guide hole in coupler is directly over silk-screened circle on bottom plate of rf and power amplifier module and slots in coupling are perpendicular to a line drawn between module tapered guide pin.

(b) Check rotors and stators of tuned circuits of rf and power amplifier module to determine whether module is properly synchronized. Module is properly synchronized when tips of stator and rotor blades of tuned circuits coincide at bottom and are displaced at top as viewed from side of module. Check position of cam that drives variable output coupling capacitor C30. Cam is properly synchronized when cam follower is at low point of cam. Refer to figure 5-27.

(c) If synchronization is required, loosen applicable rotor shaft collar, and adjust rotors for coincidence with stator by lining up tips of stator and rotor blades at bottom (figure 5-27). Adjust rotors on shaft so stator is halfway between bases of rotor blades, tighten rotor shaft collar, and replace side covers.

(d) If synchronization is required, check that rf and power amplifier module is properly aligned according to alignment procedures of paragraph 5-3e.

(3) SPECTRUM GENERATOR MODULE. Synchronize tuned circuits and printed circuit switch S3 of spectrum generator module as follows:

(a) Rotate coupler on spectrum generator module so guide hole in coupler is directly over silk-screened circle on bottom plate and slots in coupling are perpendicular to a line drawn between module guide pins.

(b) Visually check that inductor L1 is contacted by dual wiper of switch S3. Inductor L1 is color coded with red and orange dots which may be seen through observation hole adjacent to coupler. Rotate coupler until red and orange dots can be observed, rotors of tuned circuits are fully meshed, and coupler indication is over silk-screened circle. A 2 to 1 gear ratio exists between tuned circuit shaft and turret shaft. Both tuned circuits and inductor turret must be properly positioned to avoid a 180-degree ambiguity.

(c) Check position of rotor blades of tuned circuits. They should be fully meshed as illustrated in figure 5-24. If all three tuned circuits are not properly meshed, loosen gearshaft collar which clamps drive gear to turret shaft. Rotate tuned circuit shaft until all three tuned circuits are properly meshed, and tighten setscrews in gearshaft collar. If an individual tuned circuit is out of mesh, loosen setscrews in collar, and rotate rotor to a fully meshed position as shown in figure 5-24. Do not disturb position of tuner shaft while making this adjustment. Adjust rotors on shaft so stator is halfway between bases of rotor blades, and tighten setscrews.

Note

Use care in tightening setscrews. Make sure setscrews are engaging a segment of rotor shaft assembly and that they are not riding on the slots.

(d) Adjust idler gears for minimum backlash and binding.

g. REPLACEMENT.

(1) SPECTRUM GENERATOR MODULE. -Set Radio Receiver-Transmitter RT-695A/PRC-41 frequency controls to 225.0 MHz, set coupler on spectrum generator module so guide hole in coupler is directly over silk-screened circle on bottom plate. Look through hole in side cover of module, and check

that rotor and stator blades are in coincidence. Insert spectrum generator module in place on main chassis, and tighten captive screws.

**Note**

It is possible to mesh the hole in spectrum generator module coupler with pin on main chassis coupler so that tuning capacitors are in mesh. Use a screwdriver on shaft at top of the module to effect final fitting before tightening captive screws.

(2) RF AND POWER AMPLIFIER MODULE. -With RT-695A/PRC-41 still set to 225.0 MHz, set the coupler on rf and power amplifier module so guide hole in coupler is directly over silk-screened circle on bottom plate. Insert rf and power amplifier module in place on main chassis, and tighten captive screws.

**Note**

Use a screwdriver on shaft at top of the module to effect final fitting before lightening captive screws.

(3) 1ST AND 2ND IF AMPLIFIER MODULE. - Set frequency selector knobs on RT-695A/ PRC-41 to 229.9 MHz. Set couplers on 1st and 2nd if amplifier module so they are in the same relative position as the main chassis couplers. Insert the 1st and 2nd if amplifier module in place on the main chassis. Observe that couplers are properly fitted and tighten the captive screws.

**Note**

Use a screwdriver on shafts at top of the module to effect final fitting before tightening captive screws.

### **5-5. VOLTAGE AND RESISTANCE MEASUREMENTS.**

Unless noted otherwise, all voltages are taken in receive operation with Radio Receiver-Transmitter RT-695/PRC-41 set to 304.7 MHz and a signal generator input signal of 304.7 MHz, 1000 Hz modulated 30 percent at 1000 microvolts. All resistance measurements must be taken with the equipment turned OFF. Resistance measurements are not provided for transistorized circuits, since many ohmmeters will burn out the transistor if not used properly. All module voltage and resistance measurements are to be taken with the module operated on the appropriate extender cable. Refer to table 1-4. Refer to tables 5-2 through 5-14 as required for voltage and resistance measurements.

### **5- 6. LUBRICATION**

Lubrication instructions for the mechanical modules of Radio Receiver-Transmitter RT-695A/PRC-41 are contained in table 5-15. Lubrication points are designated in figures 5-29 through 5-34. These procedures should be performed only on those assemblies that obviously require lubrication. If the mechanical parts of these assemblies are suitably lubricated, do not apply lubricant, but if the lubricant is dry, caked, or dirty, clean the component with a suitable solvent, dry it with clean, oil-free compressed air, and apply the specified lubricant as instructed in table 5-15. When performing these procedures, check all setscrews in clamps and collars for secure fitting.

**CAUTION**

Overlubrication may cause serious damage to the equipment. Wipe excess lubrication from exposed parts immediately after lubrication. A thin protective film should be left after wiping. Take care not to saturate any electrical insulation or rubber with lubricant.

### **5-7. PARTS LOCATION.**

See figures 5-35 through 5-82 for location and identification of detail parts, adjustments, and test points. Refer to section 6 of this handbook for further information pertaining to any particular detail part or assembly.

**TABLE 5-2. DC POWER SUPPLY MODULE, VOLTAGE MEASUREMENTS\***

TRANSISTOR	EMITTER	BASE	COLLECTOR
Q1	0.2	-1.0	26.0
Q1	0.2	-1.0	26.0

\*Connect dc power supply module to RT-695A/PRC-41 with extension cable W5

**TABLE 5-3. 1ST AND 2ND IF AMPLIFIER MODULE, VOLTAGE MEASUREMENTS\***

TRANSISTOR	EMITTER	BASE 1	COLLECTOR	BASE 2
Q1	2.7	3.3	25.0	1.0
Q2	1.85	2.65	19.5	
Q3	4.1	4.5	25.5	2.4
Q4	0.05	0.75	0.0	0.55
Q5	3.8	3.9	23.0	2.5
Q6	0.95	0.97	18.5	
Q7	6.0	6.2	14.0	

\*Set RT-695A/PRC-41 to 3099 MHz, carefully remove 1st and 2nd If amplifier module, and connect module with extension cable W2

**TABLE 5-4. 3RD IF AND SQUELCH MODULE, VOLTAGE MEASUREMENTS**

TRANSISTOR	EMITTER	BASE 1	COLLECTOR	BASE 2
Q1	6.0	4.5	12.5	6.8
Q2	6.2	4.5	13.0	7.0
Q3	5.6	6.2	13.0	
Q4	0.35	0.5	6.5	
Q5	9.3	10.0	13.5	
Q6	14.0	14.0	10.0	
Q7	9.5	8.7	-0.2	
Q8	0.0	0.8	0.2	
Q10	*1.3, **8.2	*0.6, **7.6	0.8	

Connect 3rd If and squelch module 1A3 to RT-695A/PRC-41 with extension cable W4.  
 \*Squelch control 1A9R5 adjusted fully counterclockwise.  
 \*\*Squelch control 1A9R5 adjusted fully clockwise.

**TABLE 5-5. AUDIO MODULE, VOLTAGE MEASUREMENTS\***

TRANSISTOR	EMITTER	BASE	COLLECTOR
Q1	10.0	10.5	17.5
Q2	5.2	5.7	21.0
Q3	0.2	0.8	23.0
Q4	0.2	0.8	23.0

\*Connect audio module to RT-695A/PRC-41 with extension cable  
W5

**TABLE 5-6. SPECTRUM GENERATOR MODULE, VOLTAGE MEASUREMENTS**

TUBE	VOLTAGE	CATHODE	GRID	PLATE	HEATER	HEATER
V1		0.35	-1.5	125	0	6.3
V2		4.3	-4.4	205	0	6.3
V3		2.4	0.0	205	0	6.3
V4		4.4	0.0	205	0	6.3

\*Connect spectrum generator module to RT-695A/PRC-41 with extension cable  
W3

**TABLE 5-7. SPECTRUM GENERATOR MODULE, RESISTANCE MEASUREMENTS**

TUBE RESISTANCE	CATHODE	GRID	PLATE
.V1	100	10 k	450 k $\Omega$
V2	700	220 k	450 k $\Omega$
V3	330	0	450 k $\Omega$
V4	680	0	450 k $\Omega$

**TABLE 5-8. MODULATOR MODULE, VOLTAGE MEASUREMENTS**

TRANSISTOR	EMITTER	BASE	COLLECTOR
Q1	1.6	2.15	25.0
Q2	0.8	-0.45	22.5
Q3	0.8	-0.45	22.5

All measurements taken with a 1000-Hz, 0.7-volt (open circuit) input signal with RT-695A/PRC-41 set to 304.7 MHz in transmit operation Connect modulator module to RT-695A/PRC-41 with extension cable  
W5

**TABLE 5-9. GUARD RECEIVER MODULE, VOLTAGE MEASUREMENTS\***

TRANSISTOR	EMITTER	BASE 1	COLLECTOR	BASE 2
Q1	7.8	8.6	8.2	
Q2	7.8	8.6	8.2	
Q3	7.0	7.5	8.2	
Q4	12.2	12.3	19.0	
Q5	3.6	4.0	18.0	3.8
Q6	3.6	4.2	18.0	4.0
Q7	3.6	4.0	18.0	4.0
Q8	4.2	4.8	18.0	4.8
Q9	3.0	3.8	18.0	2.6
Q10	0.05	0.5	18.0	
Q11	17.0	16.5	9.5	
Q12	1.65	2.3	8.2	
Q13	4.5	5.2	4.6	
Q14	19.0	19.5	24.0	
Q15	14.5	14.0	7.8	

\*Set RT-695A/PRC-41 to 304.7 MHz, operate module on extension cable W3 and set SQUELCH control maximum counterclockwise. Adjust signal input for 243 0, 1000 Hz, modulated 30 percent at 1000 microvolts

**TABLE 5-10. RF AND POWER AMPLIFIER MODULE, VOLTAGE MEASUREMENTS\***

TUBE VOLTAGE	CATHODE	CONTROL GRID	PLATE	HEATER	HEATER
V1	2.45	0	195	6.3	12.6
V2	2.5	0	195	6.3	12.6
V3	2.7	0	195	6.3	12.6
V4	2.75	0	150	6.3	12.6
V5	0.2	-2.25	155	12.6	18.9

TRANSISTOR	EMITTER	COLLECTOR	BASE
Q1	0	2.3	.45

\*Measurements taken in transmit condition.  
Connect rf and power amplifier module to RT-695A/PRC-41 with extension cables W1 and W8.

**TABLE 5-11. RF AND POWER AMPLIFIER MODULE, RESISTANCE MEASUREMENTS\***

TUBE RESISTANCE	CATHODE	CONTROL GRID	PLATE
V1	1.4k $\Omega$	0	450k $\Omega$
V2	1.4k $\Omega$	0	450k $\Omega$
V3	1.4k $\Omega$	470	450k $\Omega$
V4	1.4k $\Omega$	470	450k $\Omega$
V5	33	330	450k $\Omega$

\*All resistance values in ohms

**TABLE 5-12. RADIO RECEIVER-TRANSMITTER RT-695A/PRC-41, MAIN  
CHASSIS VOLTAGE MEASUREMENTS**

TRANSISTOR	EMITTER	COLLECTOR	BASE
Q1	18.9	26.5 V	19.5

**TABLE 5-13. POWER SUPPLY PP-3700/PRC-41, NORMAL VOLTAGE MEASUREMENTS\***

TRANSISTOR	EMITTER	COLLECTOR	BASE
Q1	28.0	40.0	28.8
Q2	27.3	40.0	28.0
Q3	26.4	36.0	27.2
Q4	14.0	28.8	14.5

\*Measurements taken in transmit condition (3 amperes) 115-volt input.

**TABLE 5-14. POWER SUPPLY PP-3700/PRC-41, OVERLOAD TRIP VOLTAGE MEASUREMENTS\***

TRANSISTOR	EMITTER	COLLECTOR	BASE
Q1	0.3	60	0.8
Q2	0.11	60	0.3
Q3	0.1	50	0.1
Q4	0.7	0.8	1.4

\*Measurements taken in transmit condition (3 amperes) 115-volt input after overload trip has been actuated by shorting P1 to P3.



**TABLE 5-15. LUBRICATION INSTRUCTIONS**

MODULE	PART	REFERENCE	FIGURE	LUBRICANT	METHOD OF APPLICATION	
Rf and power amplifier module	Contact arm and contact ring	1	5-29, 5-30	Note 1	Apply thin film with a pipe cleaner.	
	Ground springs	2	5-29, 5-30	Note 1	Apply thin film with a pipe cleaner.	
1st and 2nd if amplifier module	Switches	3	5-31	Note 1	Apply thin film with a pipe cleaner.	
	Sleeve bearings	4	5-31	MIL-L-6085A (note 2)	Apply two drops with a pipe cleaner.	
Spectrum generator module	Inductor arms and inductor rings	5	5-32	Note 1	Apply thin film with a pipe cleaner.	
	Grounding springs	6	5-32	Note 1	Apply thin film with a pipe cleaner.	
	Sleeve bearings	7	5-32	MIL-L-6085A (note 2)	Apply two drops with a pipe cleaner.	
	Gear teeth and idler shafts	8	5-32	Texaco Uni-Temp Grease 500 (005-0662-00)	Brush	
	Switch contacts	9	5-32	Note 1	Apply thin film with a pipe cleaner.	
	RT-695A/ PRC-41 main chassis	Switch contacts	10	5-33, 5-34	Note 1	Apply thin film with a pipe cleaner.
		Sleeve bearings	11	5-33, 5-34	MIL-L-6085A (Note 2)	Apply two drops with a pipe cleaner.
Bevel gear teeth pivot post and detents		12	5-33, 5-34	Texaco Uni-Temp Grease 500 (005-0662-00)	Brush.	
Ball bearings		13	5-33, 5-34	MIL-L-6085A (Note 2)	Apply two drops with a dropper.	
Helical gears		14	5-33, 5-34	Note 1	Brush.	
Ends of shaft	15	5-33, 5-34	Note 1	Brush.		
Sleeve bearing	16	5-33, 5-34	MIL-L-6085A (note 2)	Apply two drops with a pipe cleaner		

**NOTES:**

- Lubricant consists of 10 parts by weight of MIL-G-3278 grease, 45 parts by weight of butyl alcohol, and 45 parts by weight of xylene.
- Federal stock number 9150-261-8298.
- Federal stock number 9150-223-4129.

Figure 5-29-

NAVSHIPS 0967-872-5020  
TM-03816B-35/2  
TM11-5820-510-35-1

AN/PRC-41A  
MAINTENANCE

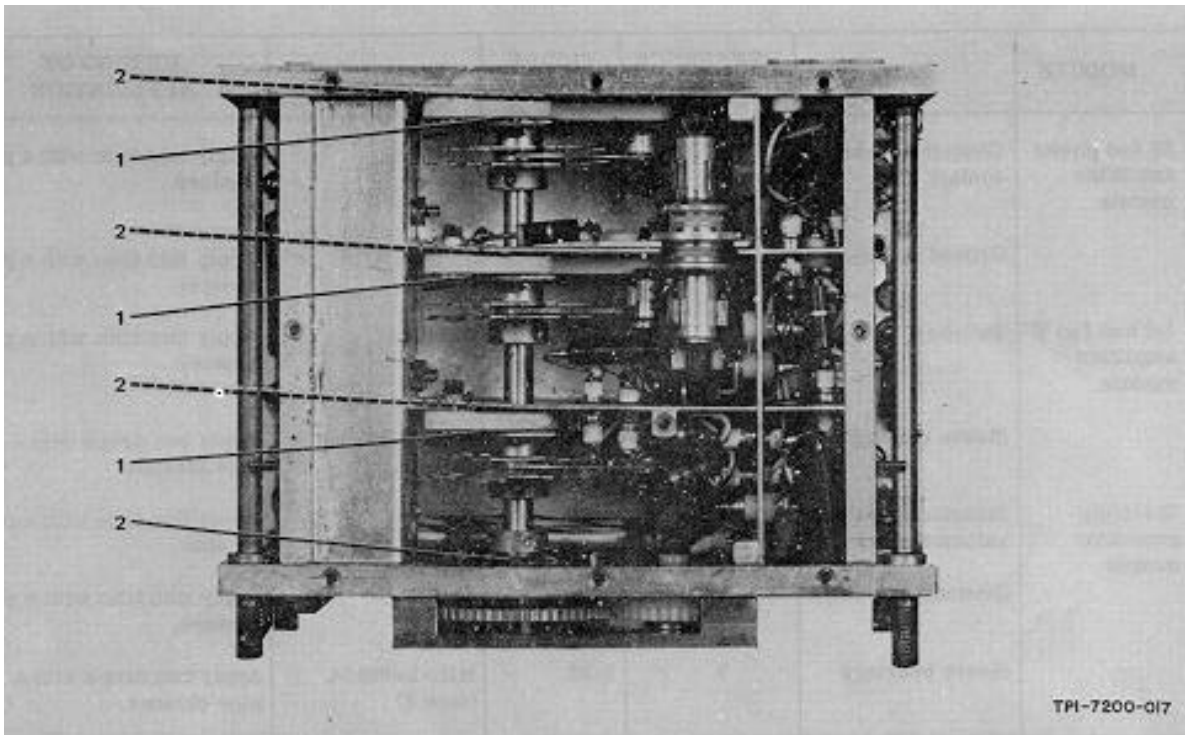

Figure 5-29. RF and Power Amplifier Module, Left Side View, Lubrication Points

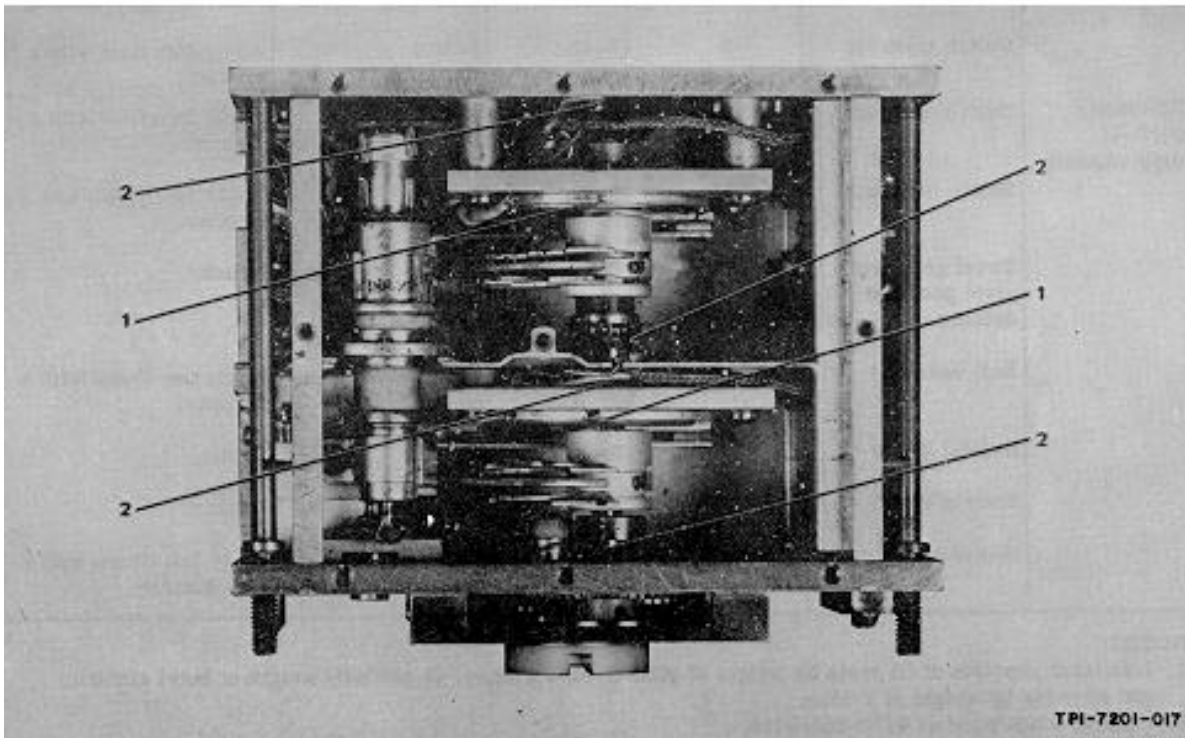

Figure 5-30. RF And Power Amplifier Module, Right Side View, Lubrication Points

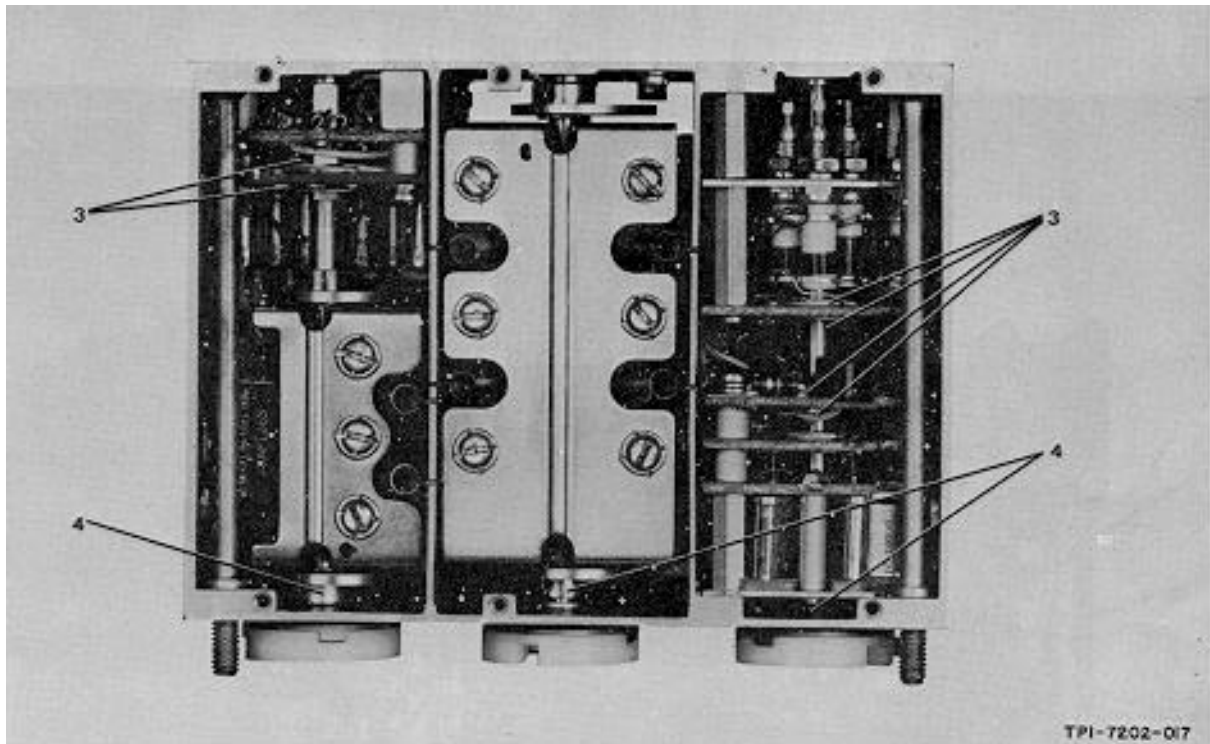

Figure 5-31. 1st and 2nd IF Amplifier Module, Lubrication Points

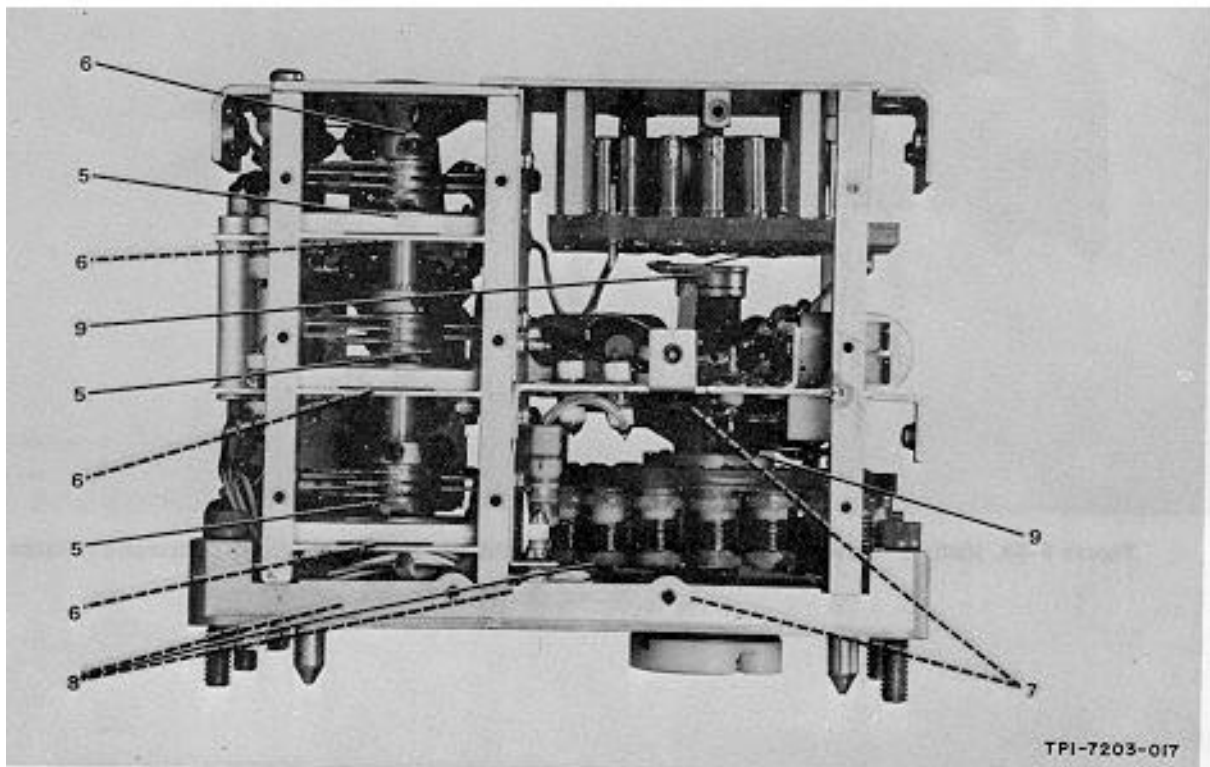

Figure 5-32. Spectrum Generator Module, Lubrication Points

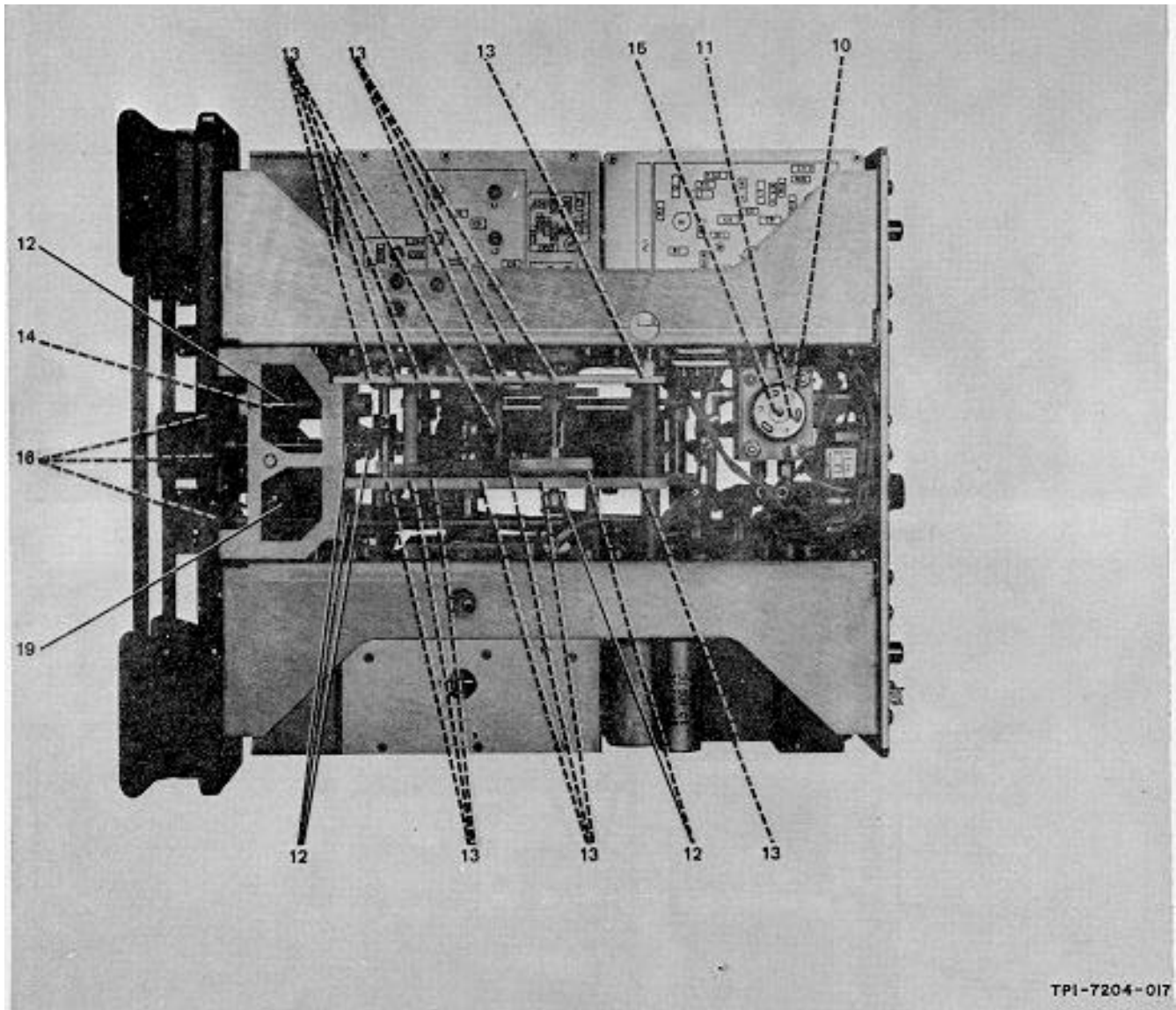

Figure 5-33. Radio Receiver-Transmitter RT-695A/PRC-41, Right Side View, Lubrication Points

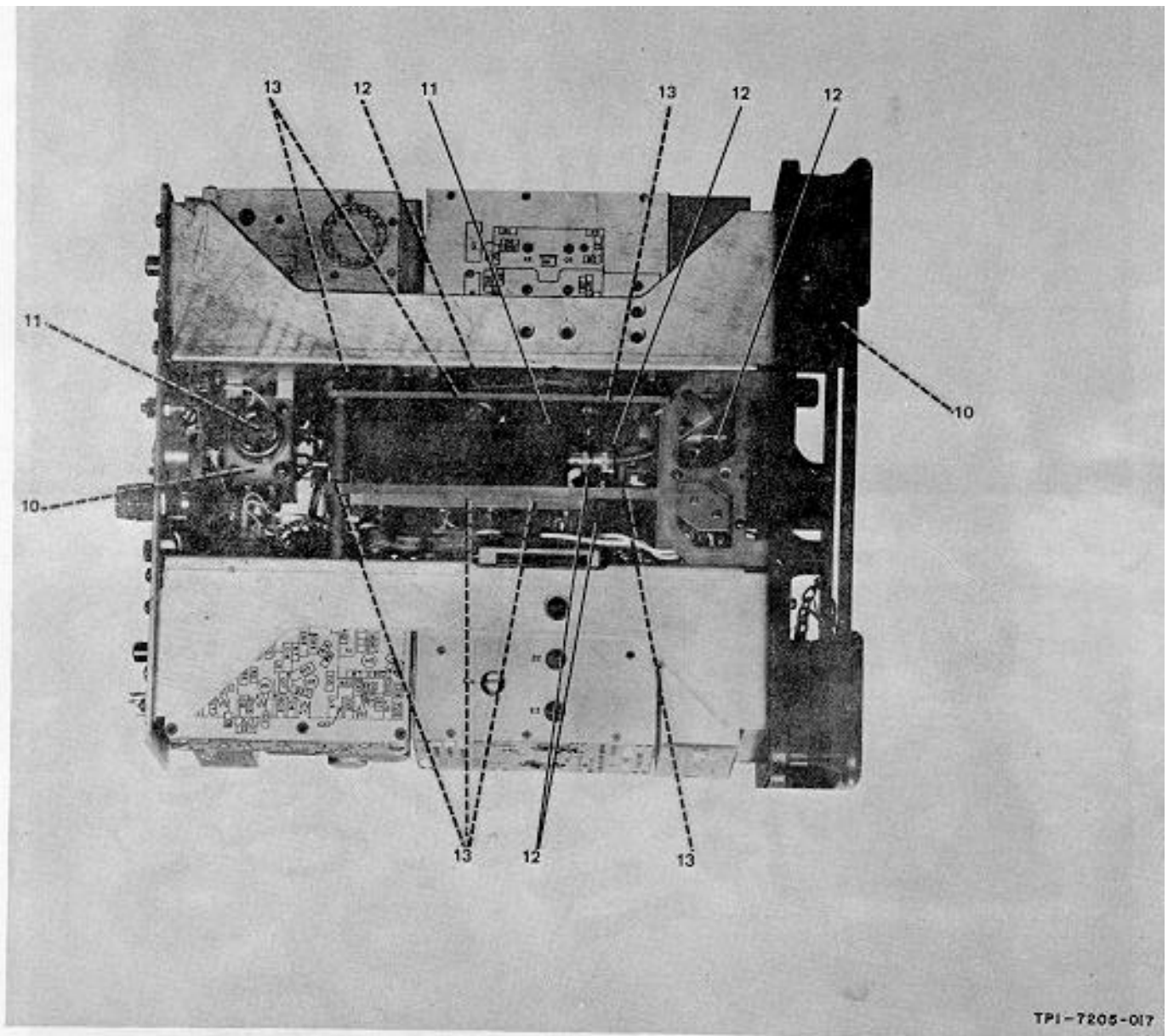

Figure 5-34. Radio Receiver-Transmitter RT-695A/PRC-41, Left Side View, Lubrication Points

Figure 5-35

NAVSHIPS 0967-872-5020  
TM-03816B-35/2  
TM11-5820-510-35-1  
TM11-5820-510-35-1

AN/PRC-41A  
MAINTENANCE

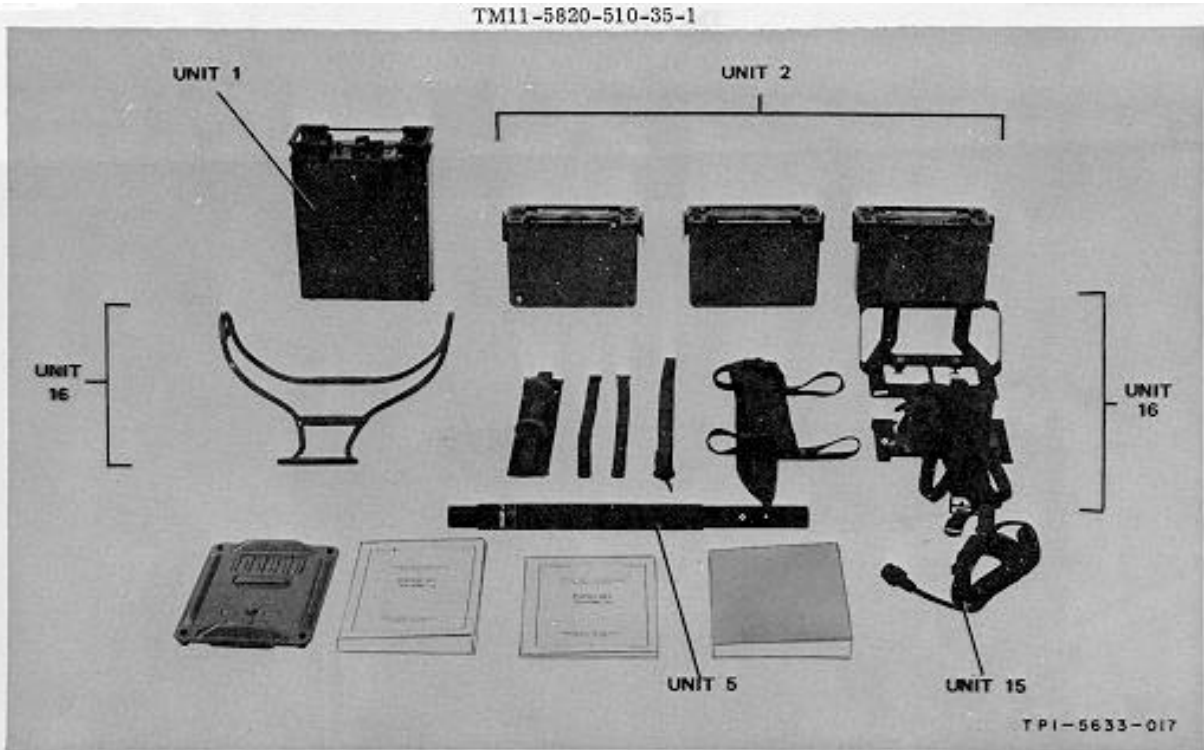

Figure 5-35. Radio Rat AN/PRC-41A. Parts List Unit Designation

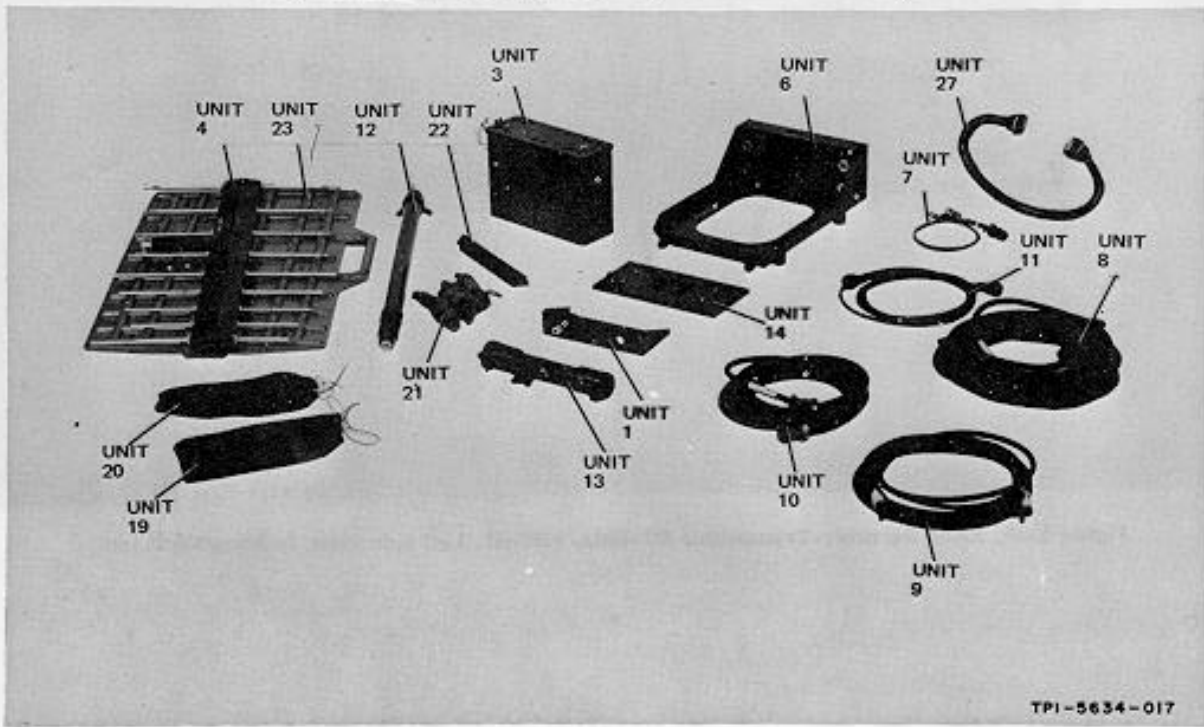

Figure 5-36. Radio Set Accessory Kit MK-706/PRC-41, Parts List Unit Designation

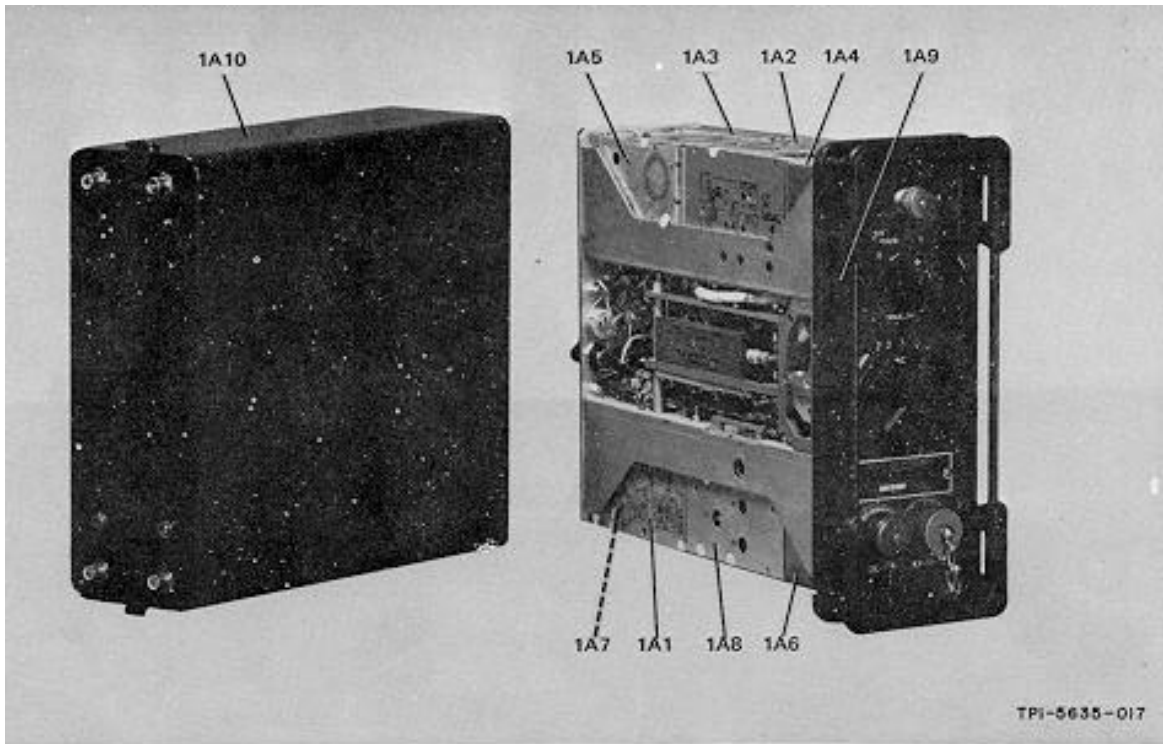

Figure 5-37. Radio Receiver-Transmitter RT-695A/PRC-41 and Receiver-Transmitter

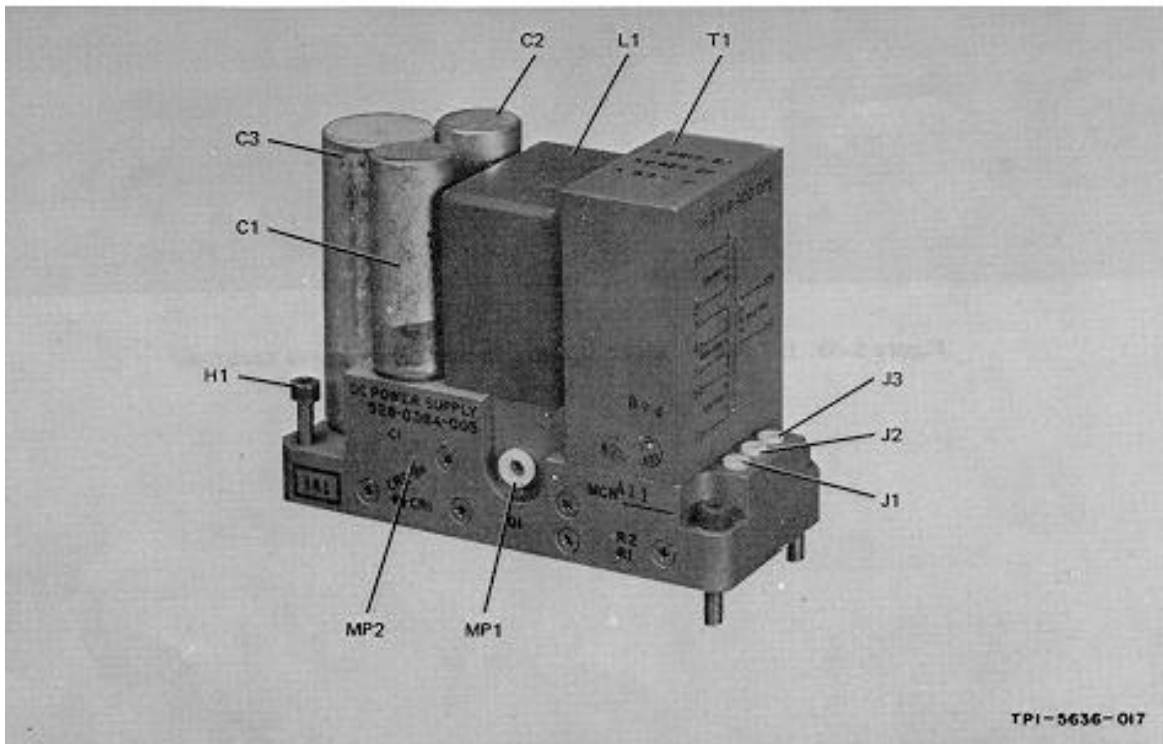

Figure 5-38. DC Power Supply Module, Oblique View, Parts Location

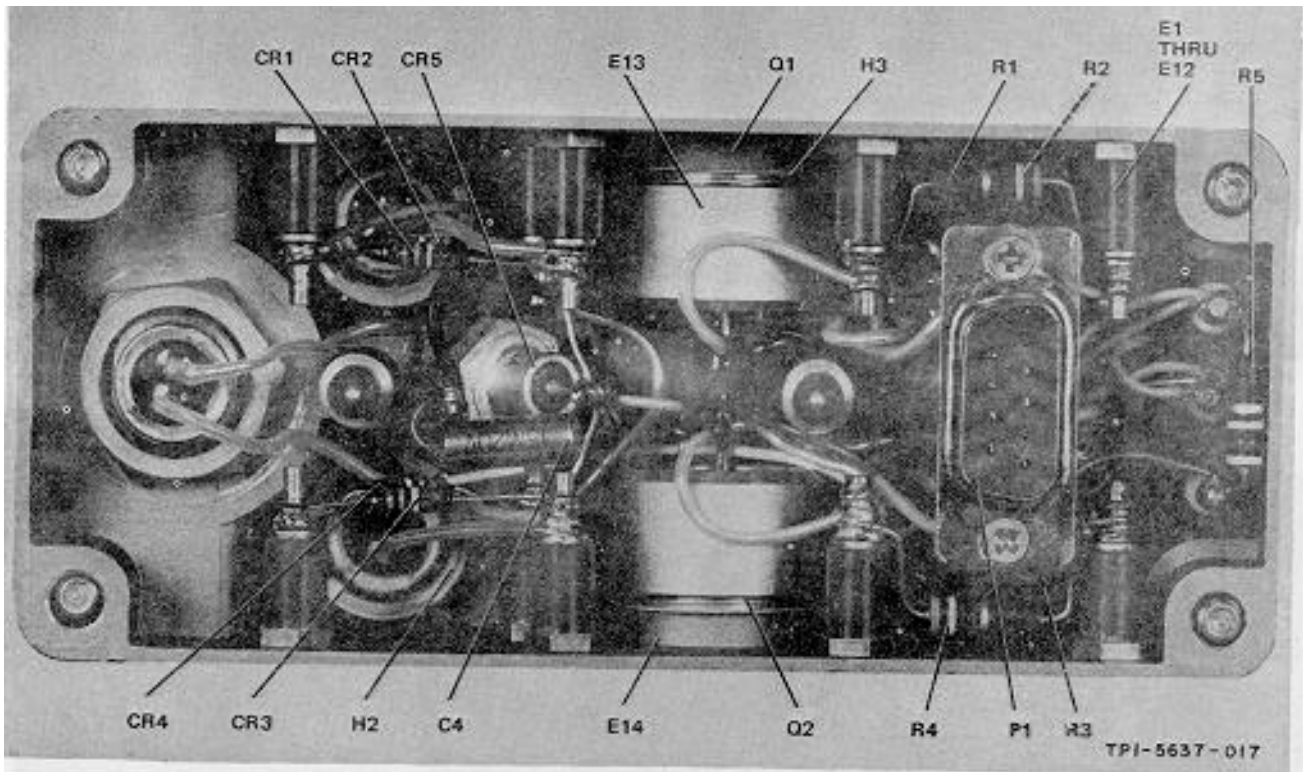

Figure 5-39. DC Power Supply Module, Bottom View, Parts Location



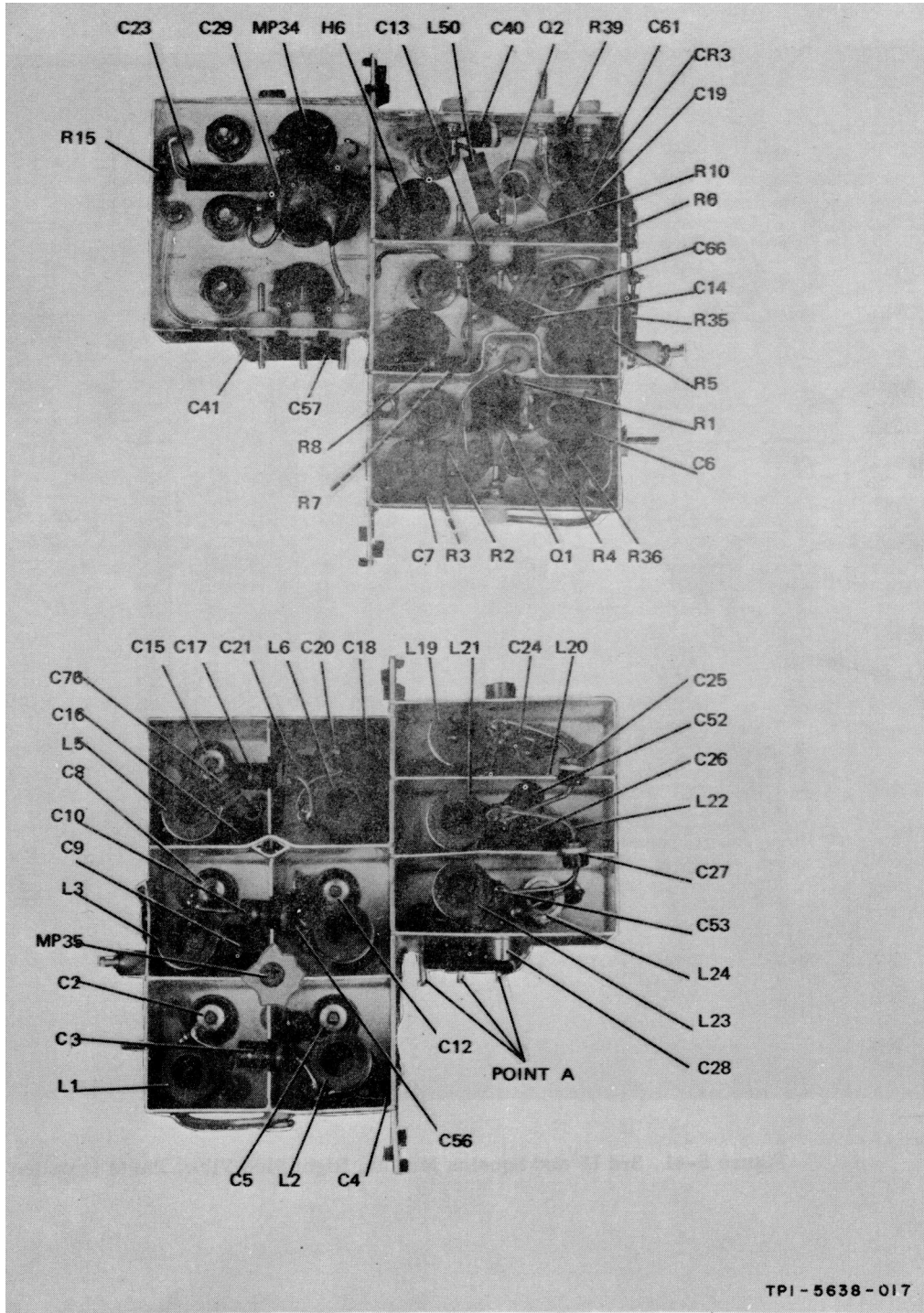

Figure 5-40. 1st and 2nd IF Amplifier Module, Wired Bracket, Parts Location

ORIGINAL

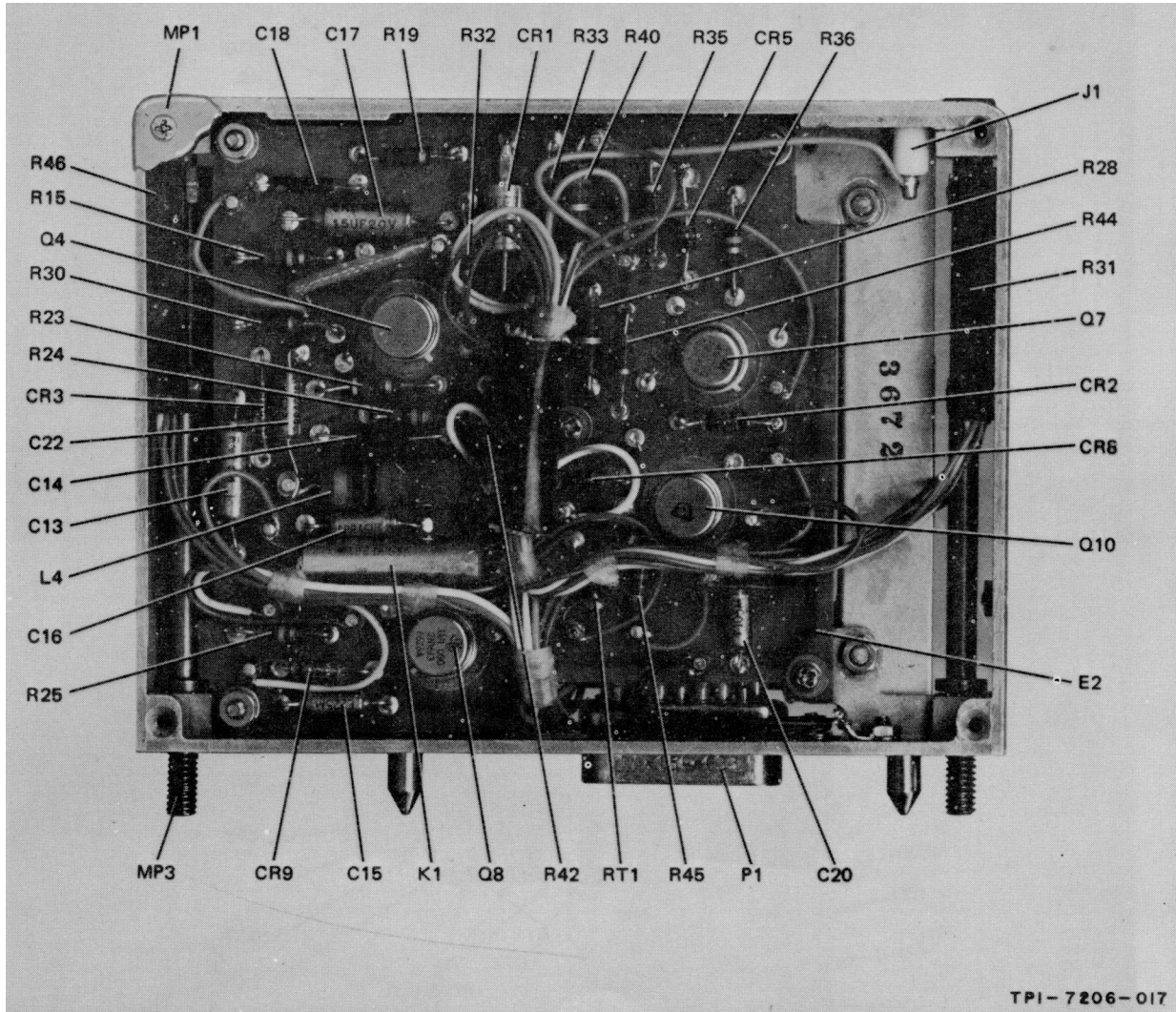

Figure 5-41. 3rd IF and Squelch Module, Right Side View, Parts Location

ORIGINAL

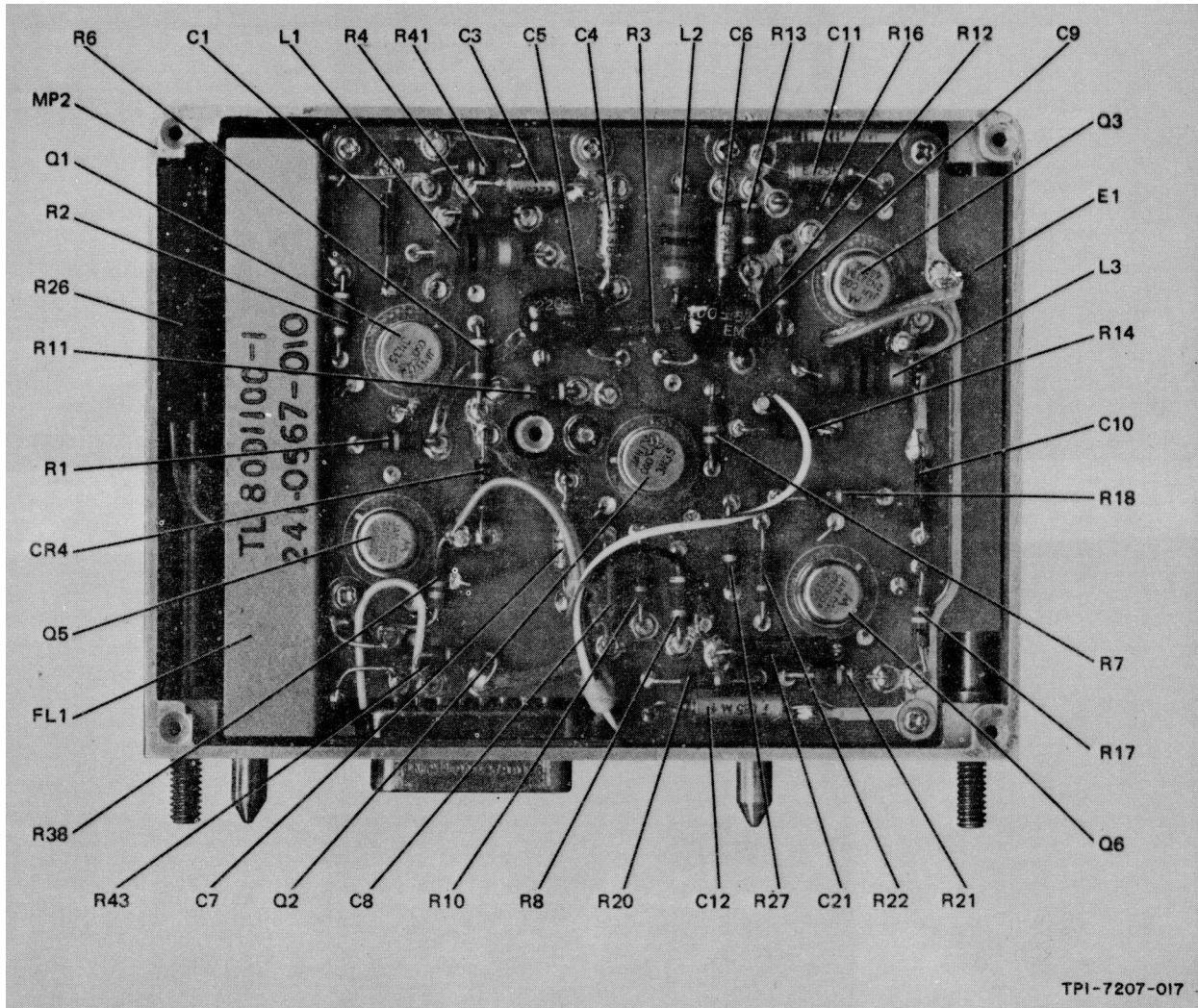

Figure 5-42. 3rd IF and Squelch Module, Left Side View, Parts Location

ORIGINAL

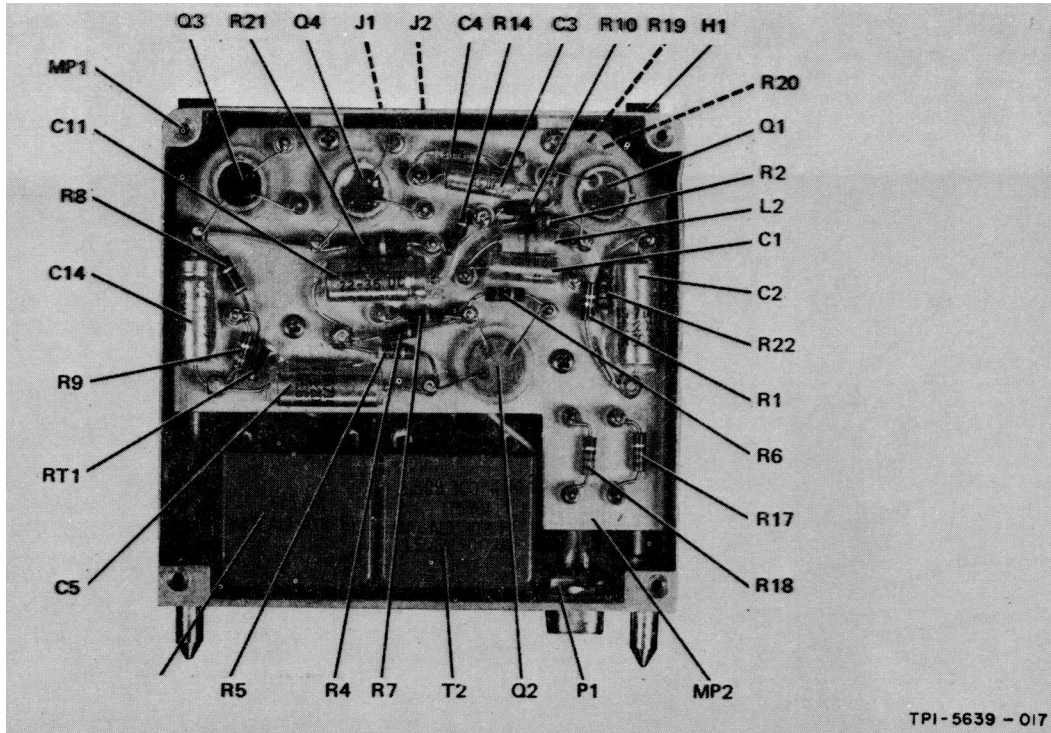

Figure 5-43. Audio Amplifier Module, Rear View, Parts Location

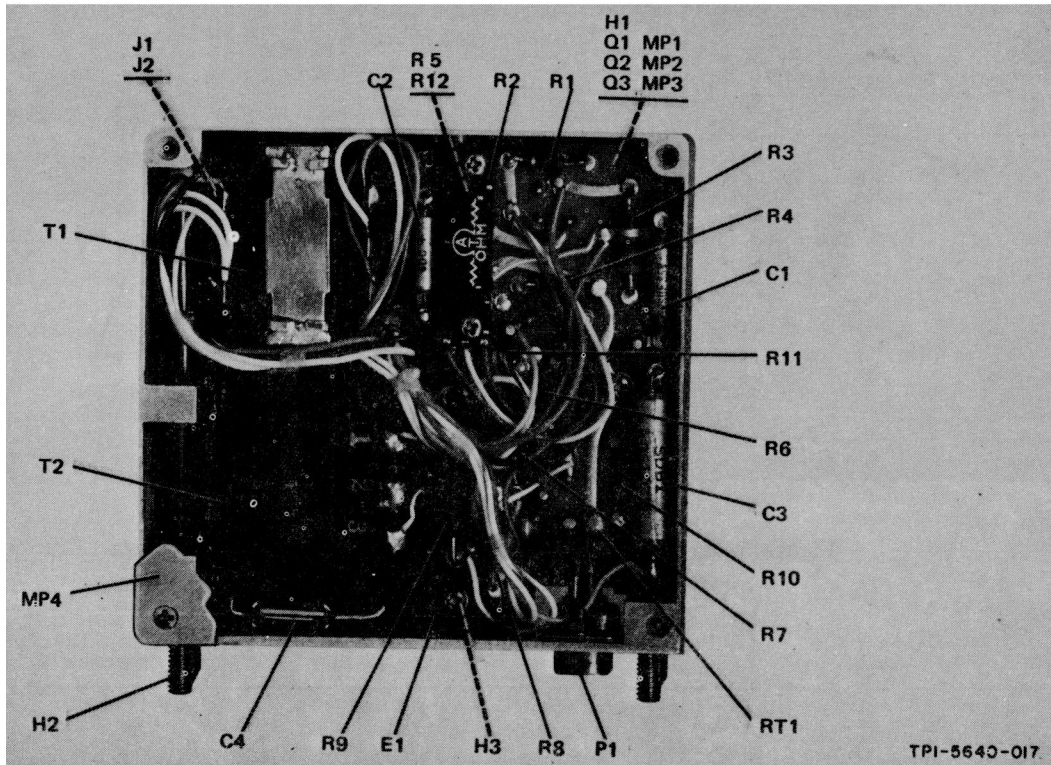

Figure 5-44. Modulator Module, Front View, Parts Location

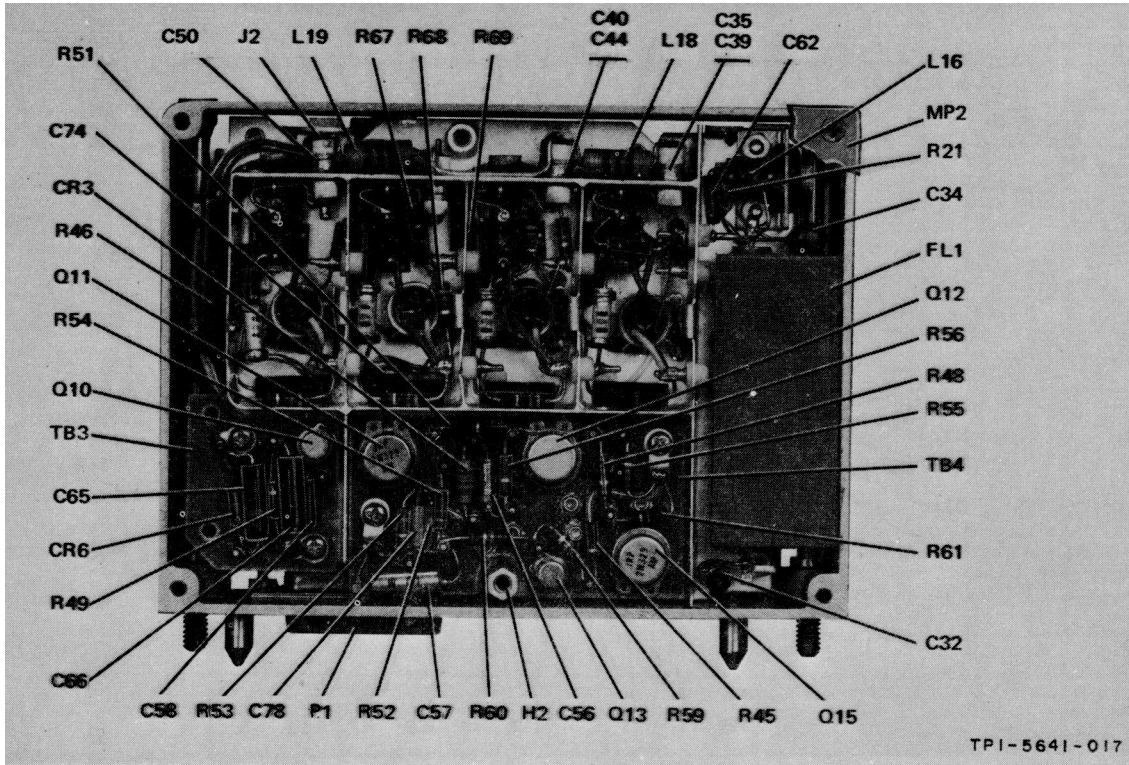

Figure 5-45. Guard Receiver Module, Right Side View, Parts Location

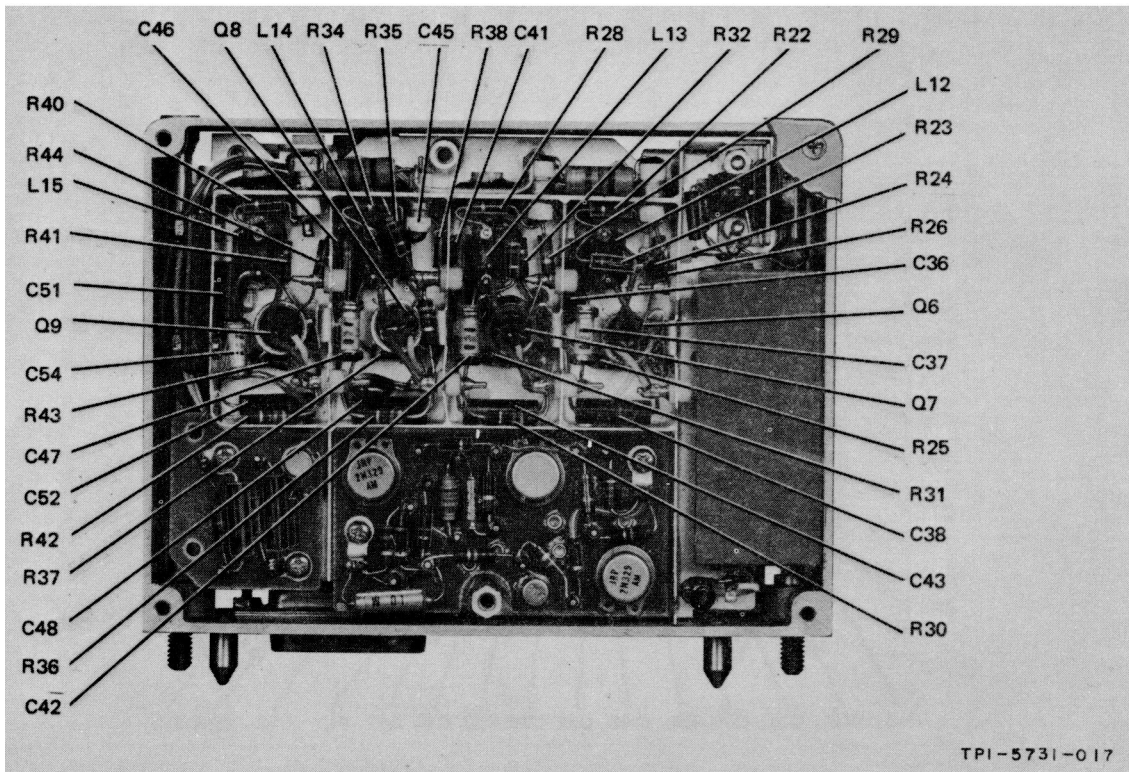

Figure 5-46. Guard Receiver Module, Right Side View, Parts Location

ORIGINAL

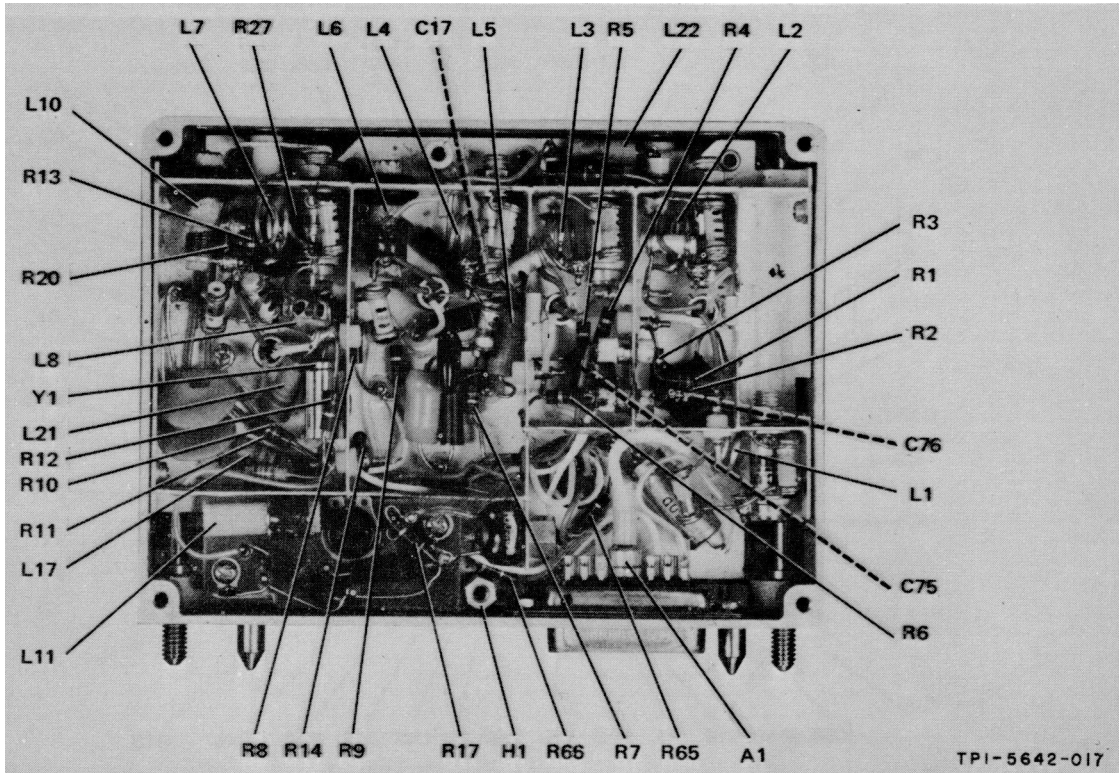

Figure 5-47. Guard Receiver Module, Left Side View, Parts Location

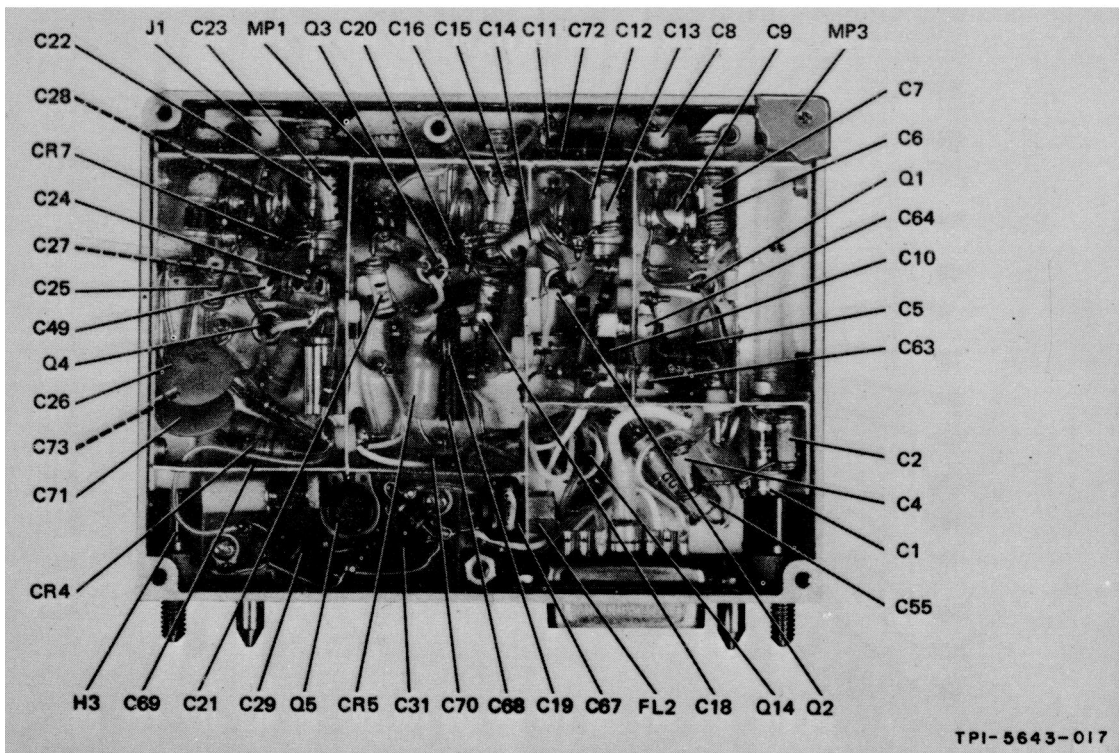

Figure 5-48. Guard Receiver Module, Left Side View, Parts Location

ORIGINAL

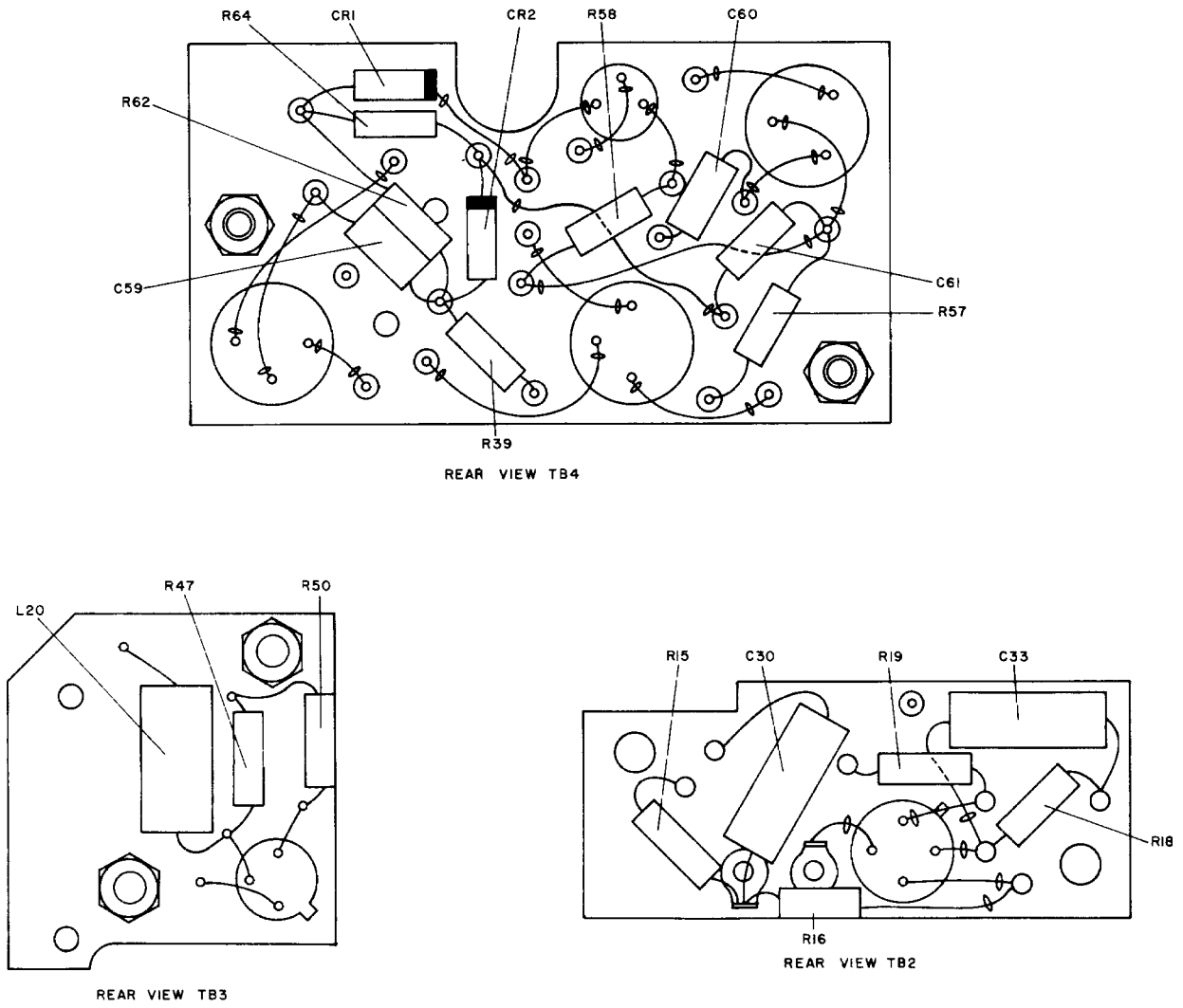

Figure 5-49. Guard Receiver Module, Terminal Board, Parts Location

ORIGINAL

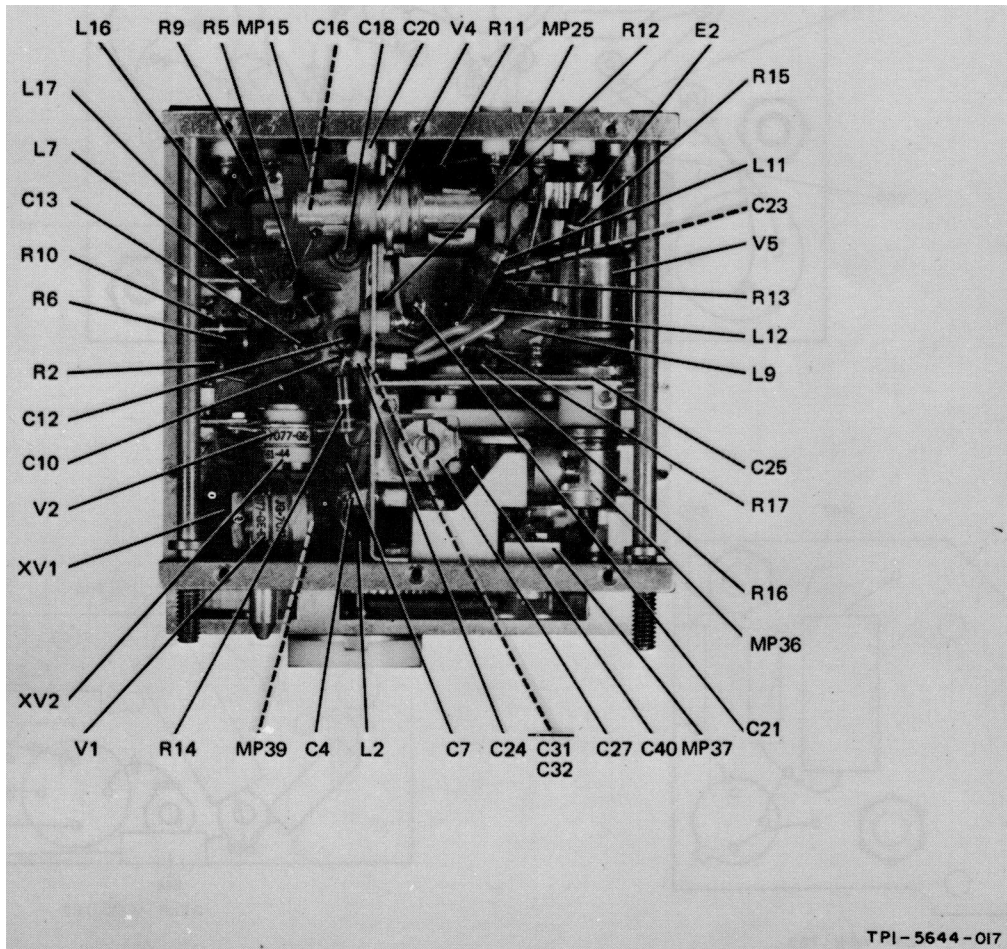

Figure 5-50. RF and Power Amplifier Module, Rear View, Parts Location

ORIGINAL



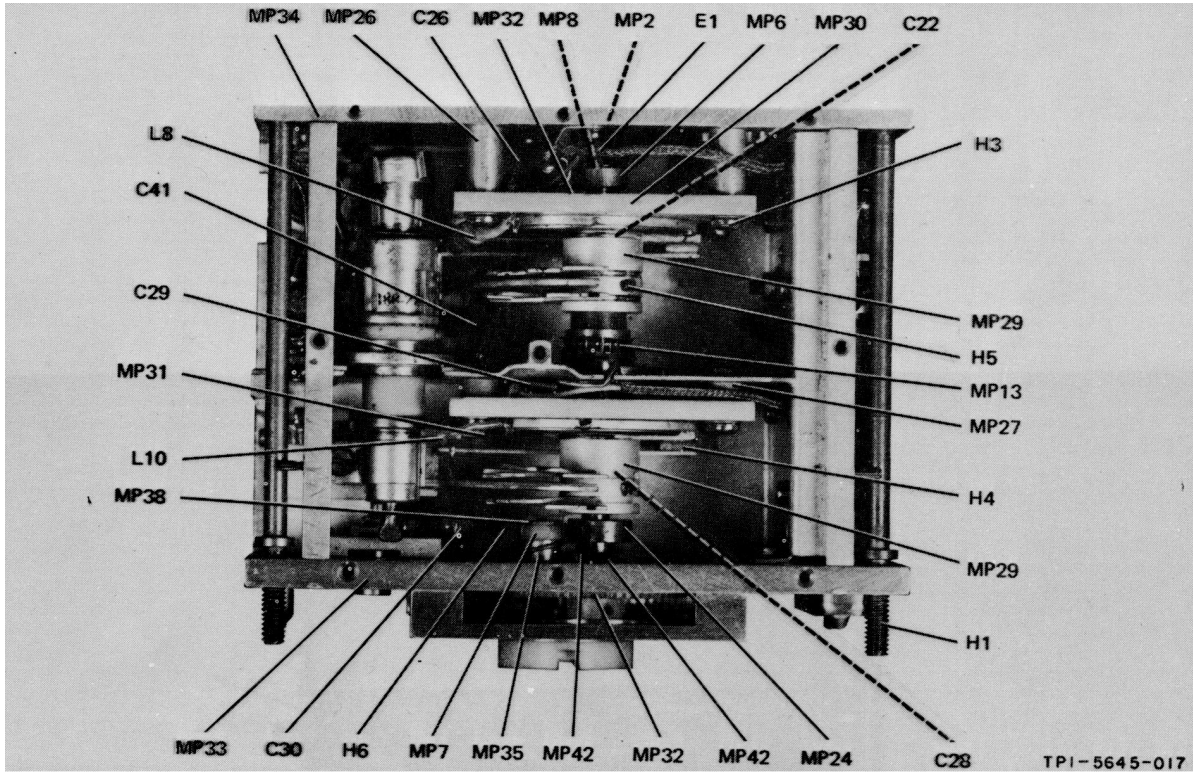

Figure 5-51. RF and Power Amplifier Module, Left Side View, Parts Location

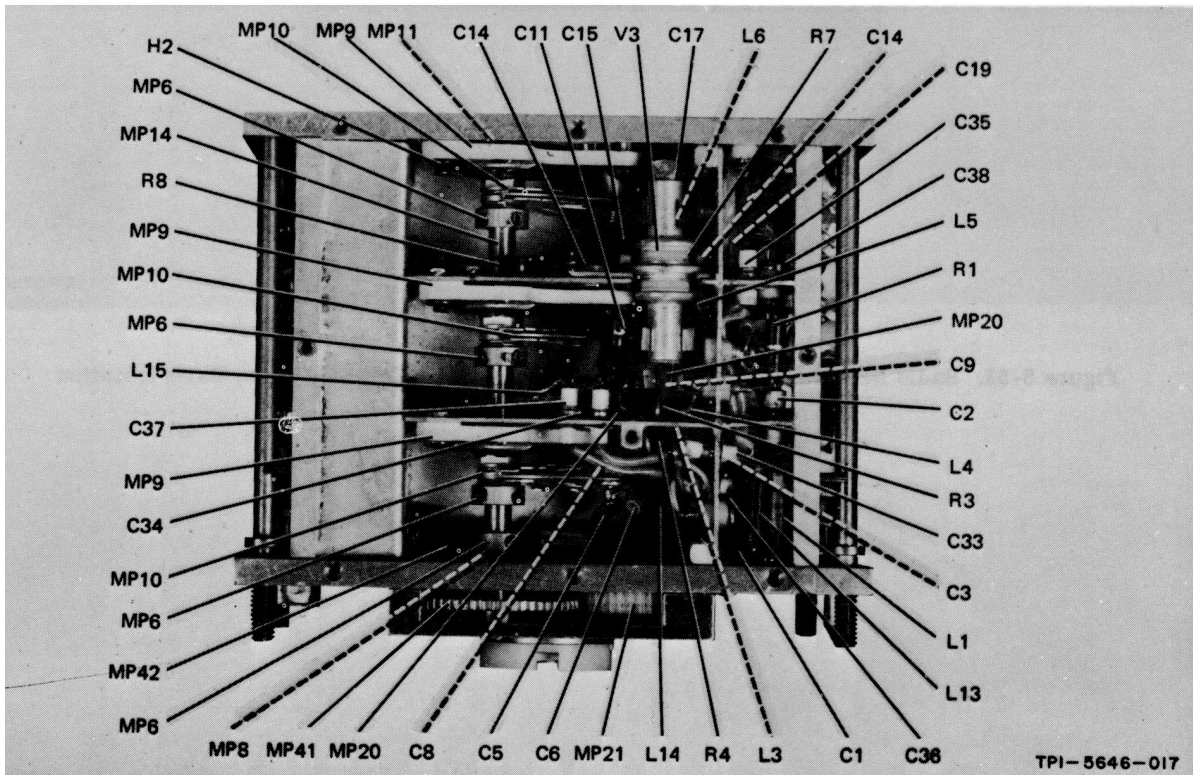

Figure 5-52. RF and Power Amplifier Module, Right Side View, Parts Location

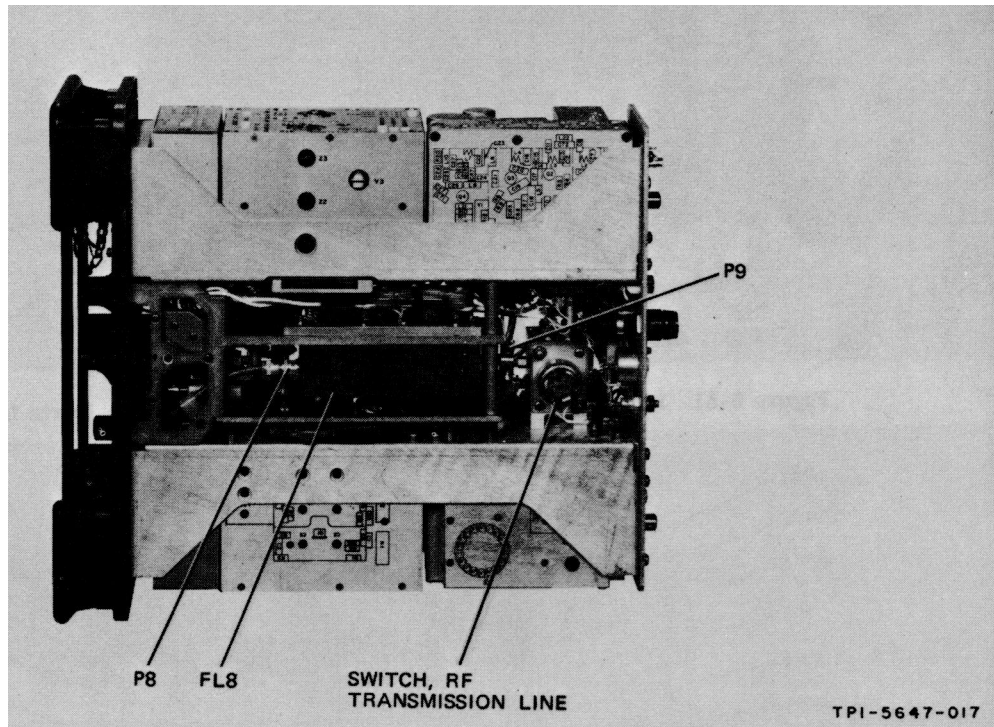

Figure 5-53. Radio Receiver-Transmitter RT-695A/PRC-41, Left Side View, Parts Location

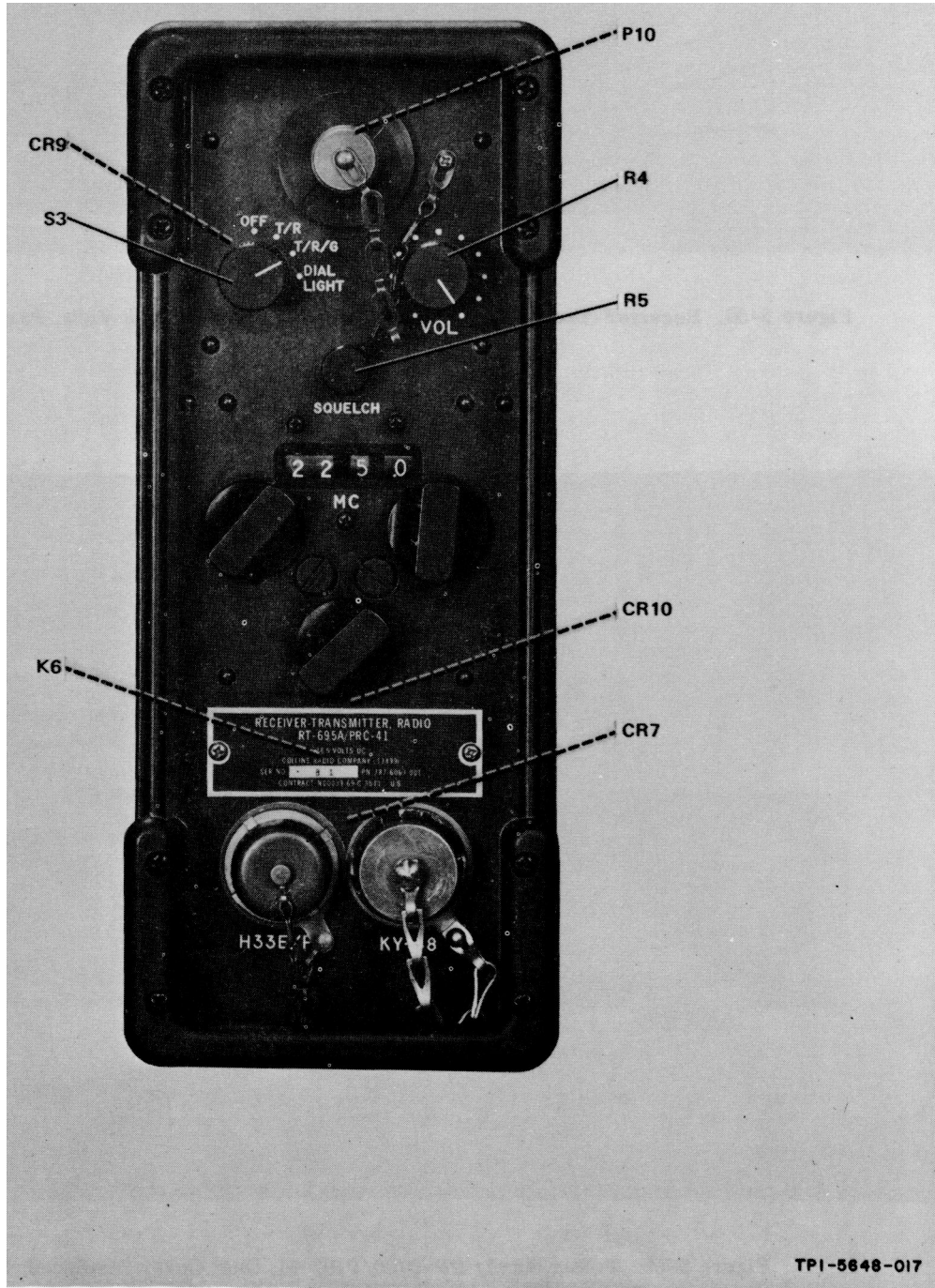

Figure 5-54. Radio Receiver-Transmitter RT-695A/PRC-41, Front Panel, Parts Location

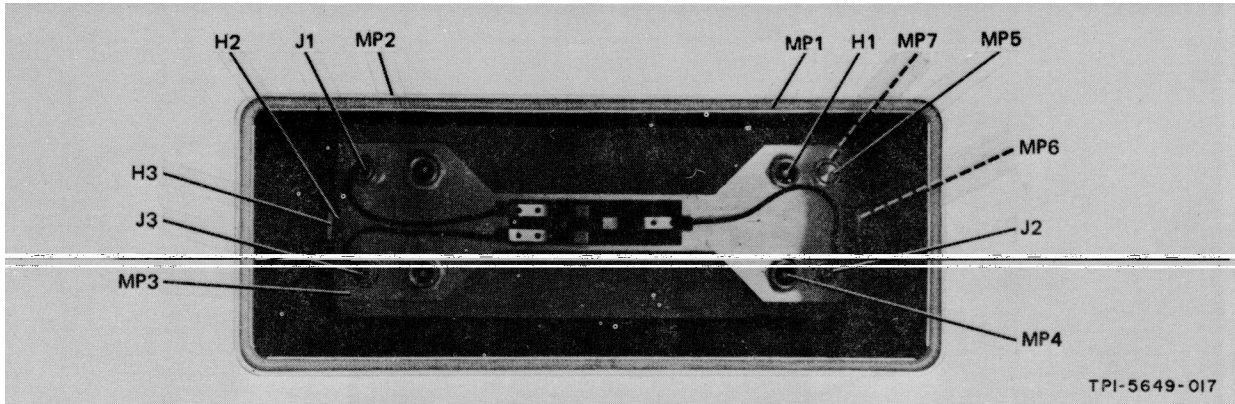

Figure 5-55. Receiver-Transmitter Case CY-3884/PRC-41, Inside View, Parts Location

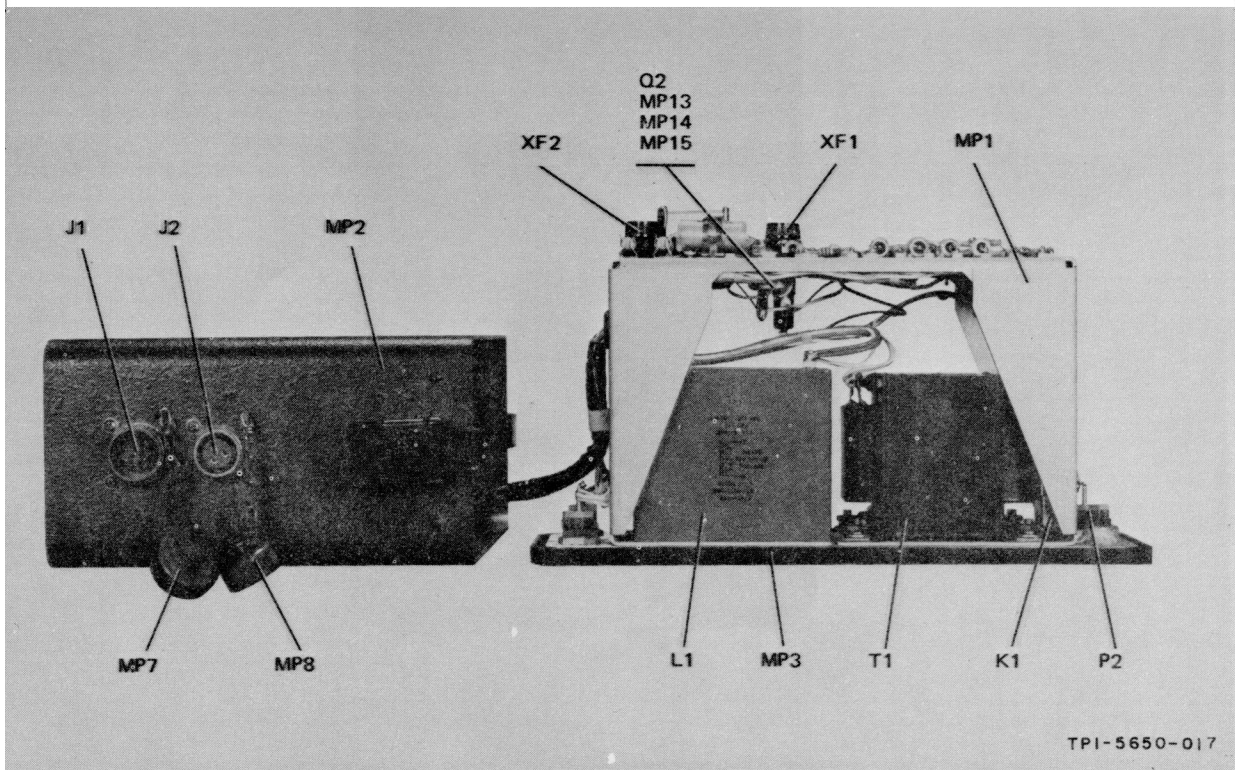

Figure 5-56. Power Supply PP-3700/PRC-41, Dust Cover Displaced, Parts Location

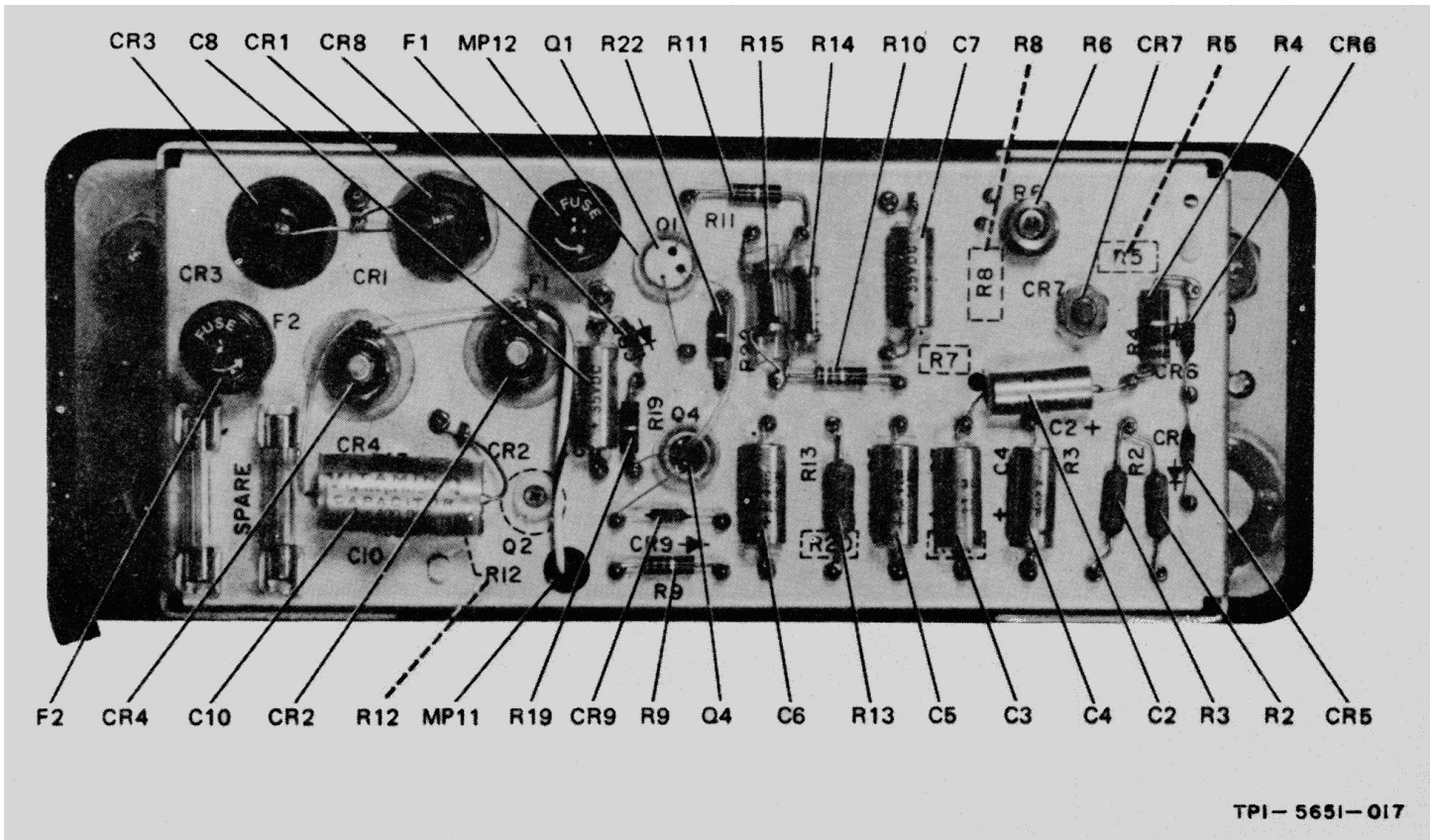

Figure 5-57. Power Supply PP-3700/PRC-41, Bottom View, Dust Cover Removed, Parts Location

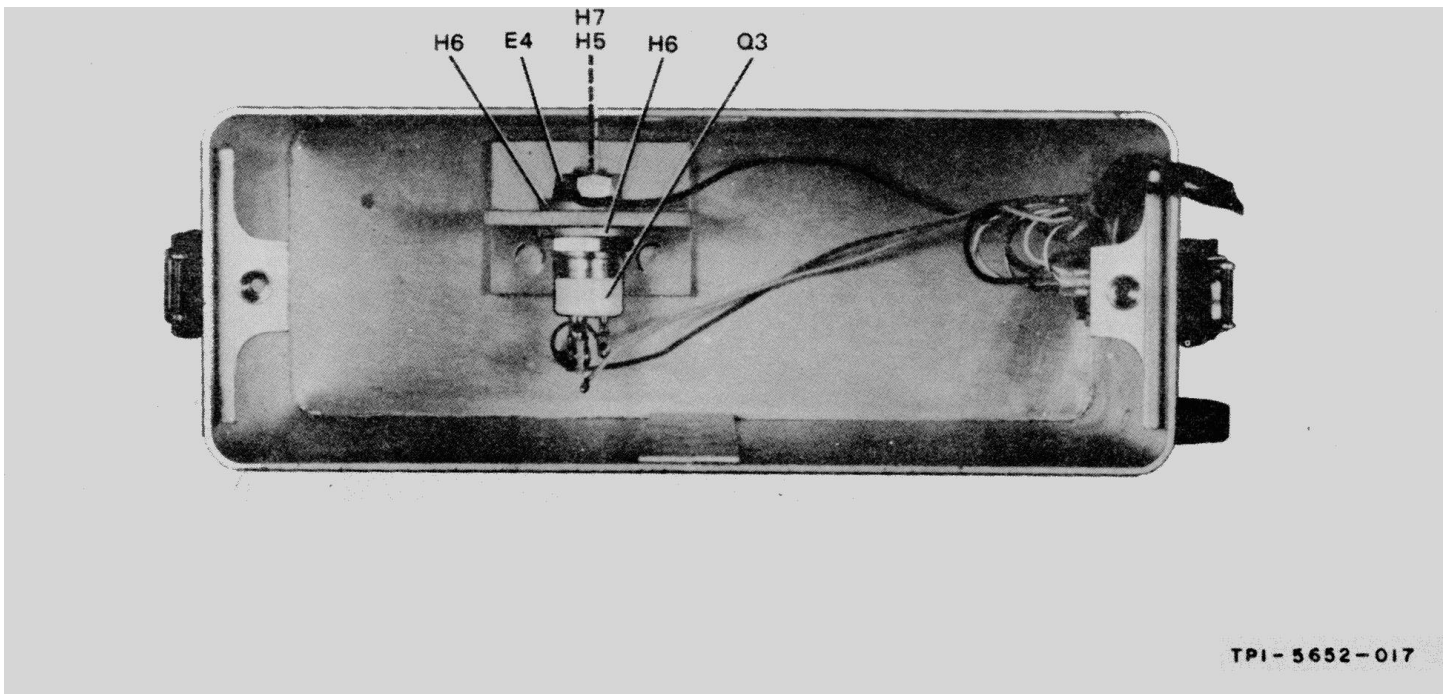

Figure 5-58. Power Supply PP-3700/PRC-41, Side View, Dust Cover Removed, Parts Location.

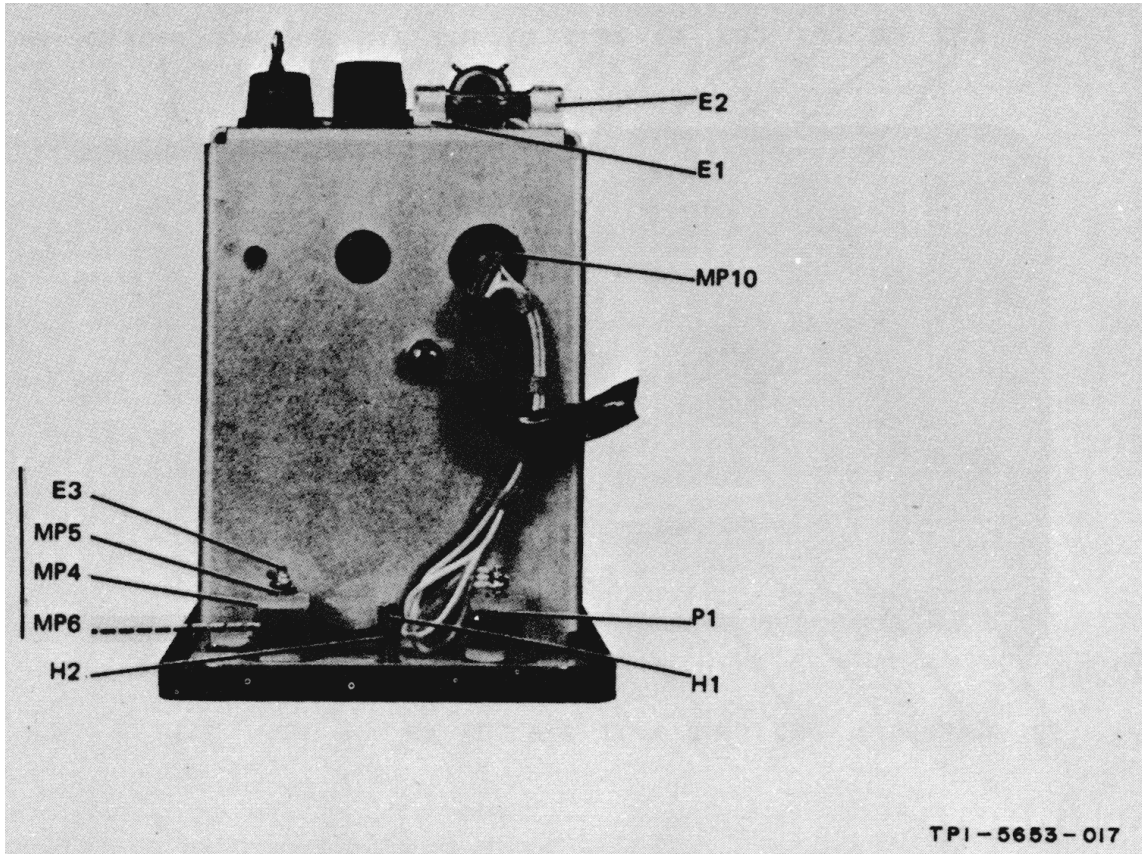

Figure 5-59. Power Supply PP-3700/PRC-41, End View, Dust Cover Removed, Parts Location

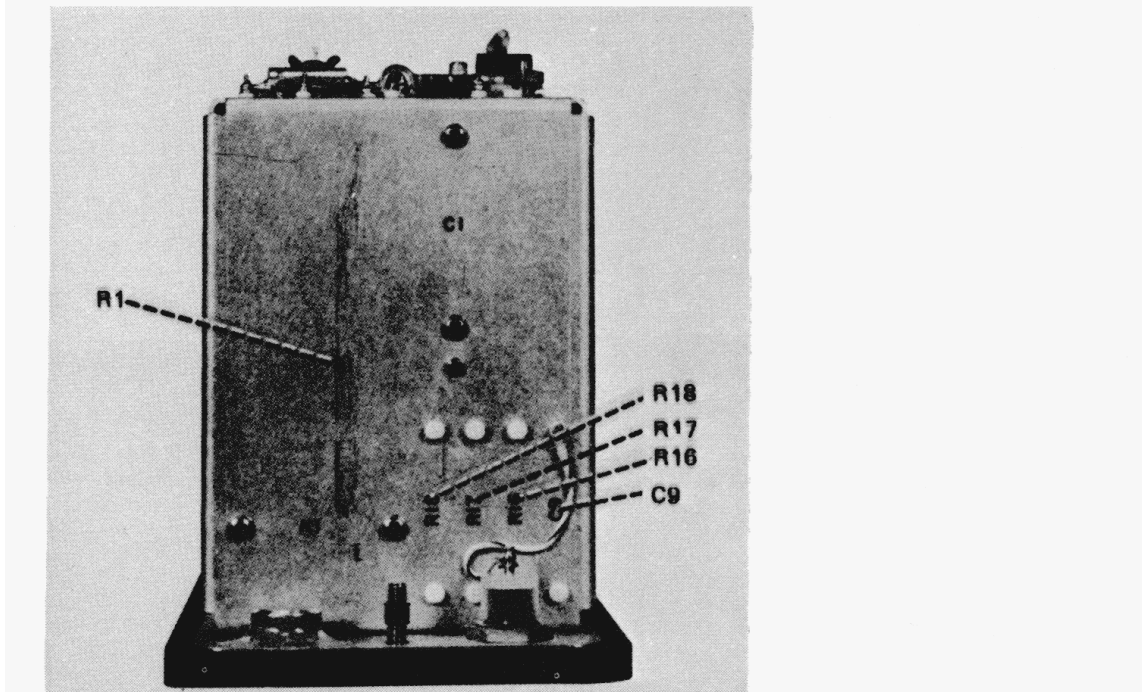

Figure 5-60. Power Supply PP-3700/PRC-41, Oblique View, Parts Location

ORIGINAL

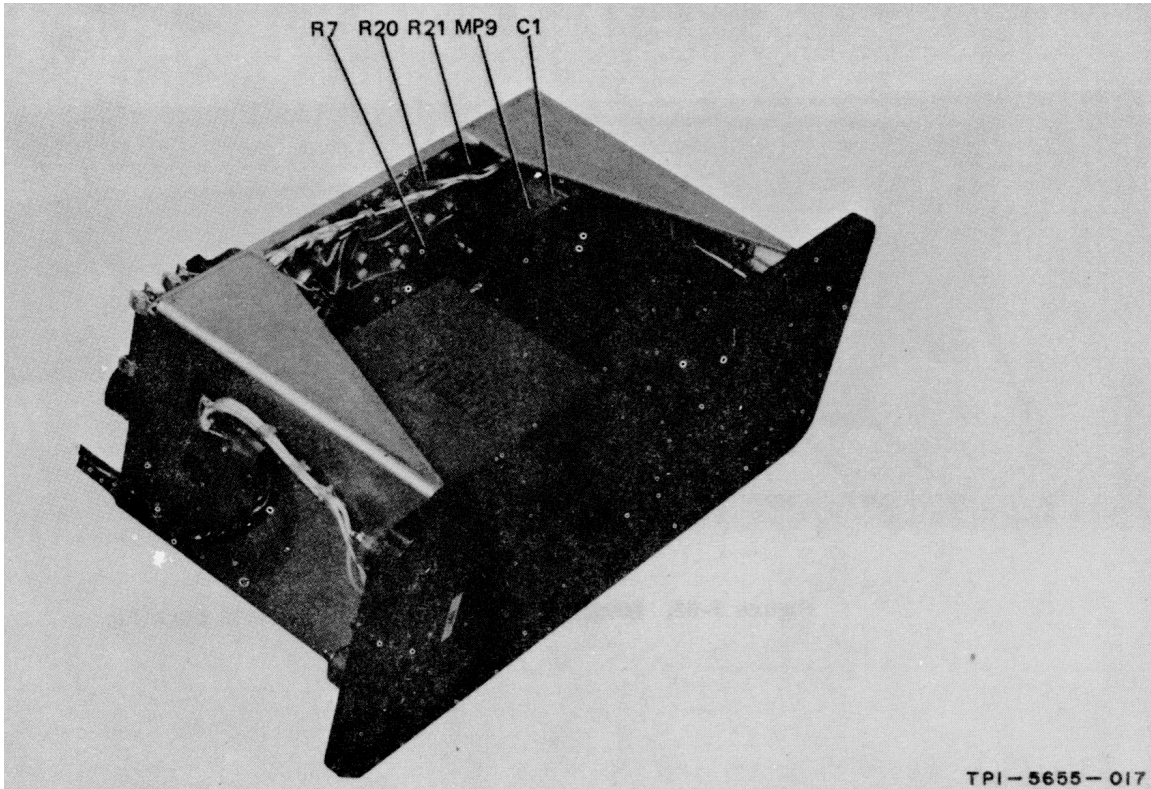

Figure 5-61. Power Supply PP-3700/PRC-41, Side View, Dust Cover Removed, Parts Location

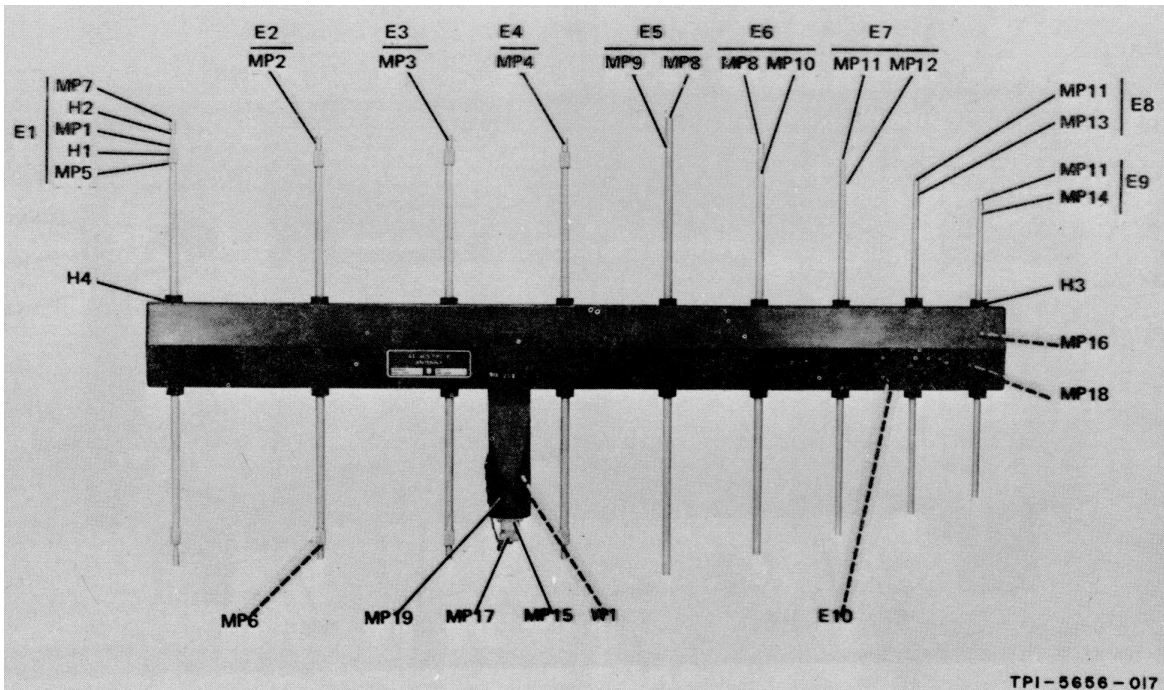

Figure 5-62. Antenna AS-1405/PRC-41, Parts Location

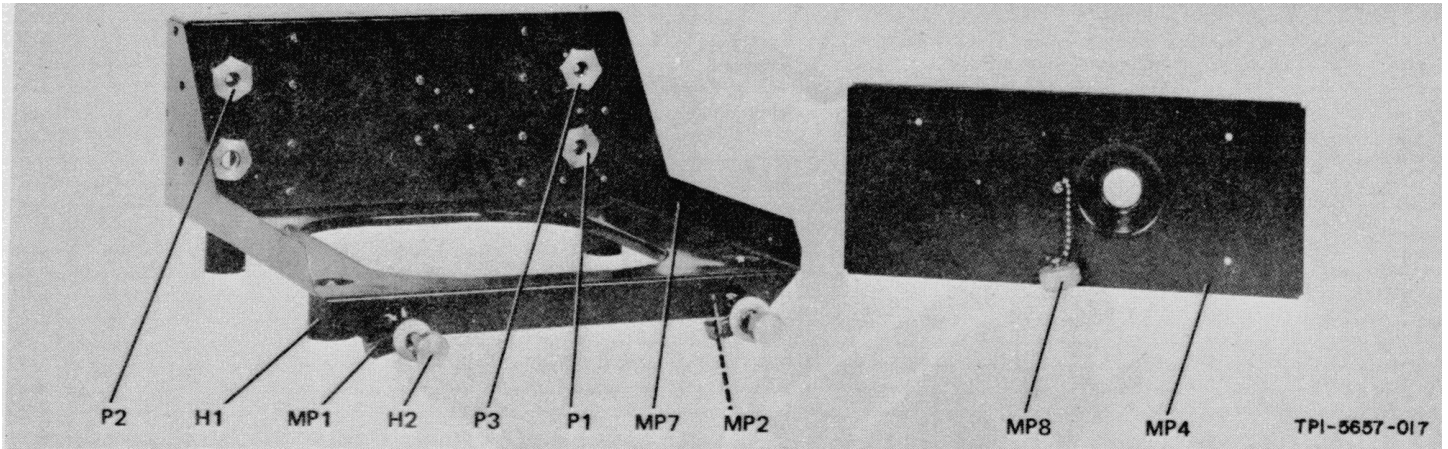

Figure 5-63. Mounting MT-2976/PRC-41, Parts Location

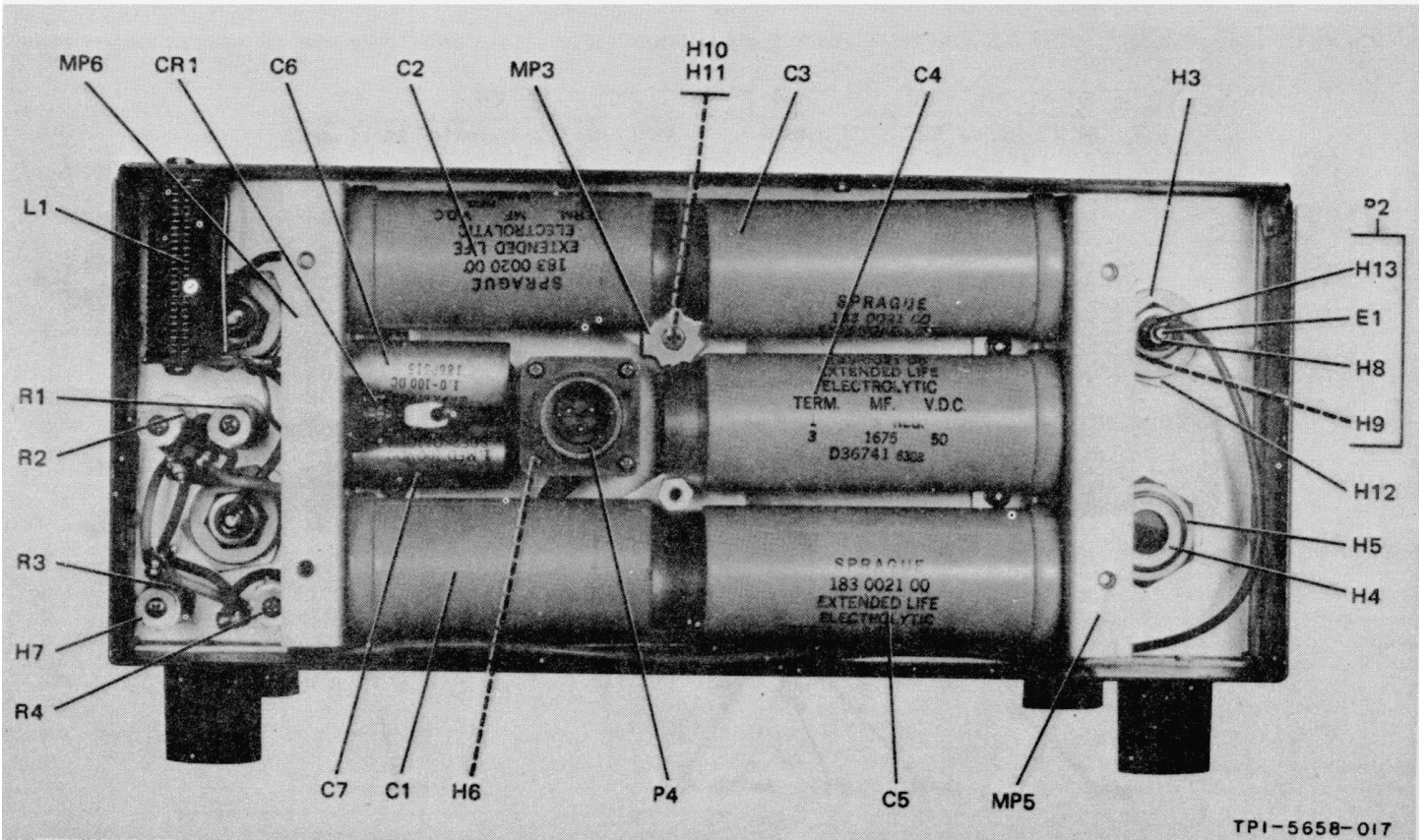

Figure 5-64. Mounting MT-2976/PRC-41, Rear View, Parts Location



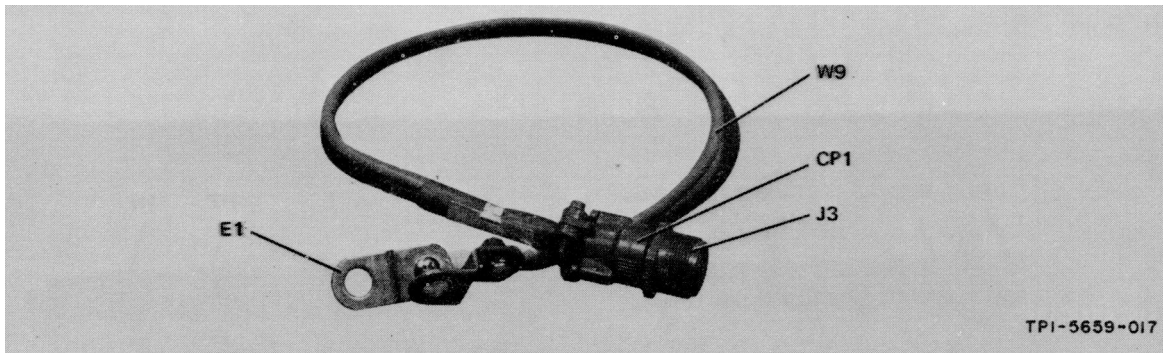

Figure 5-65. DC Adapter Cable, Parts Location

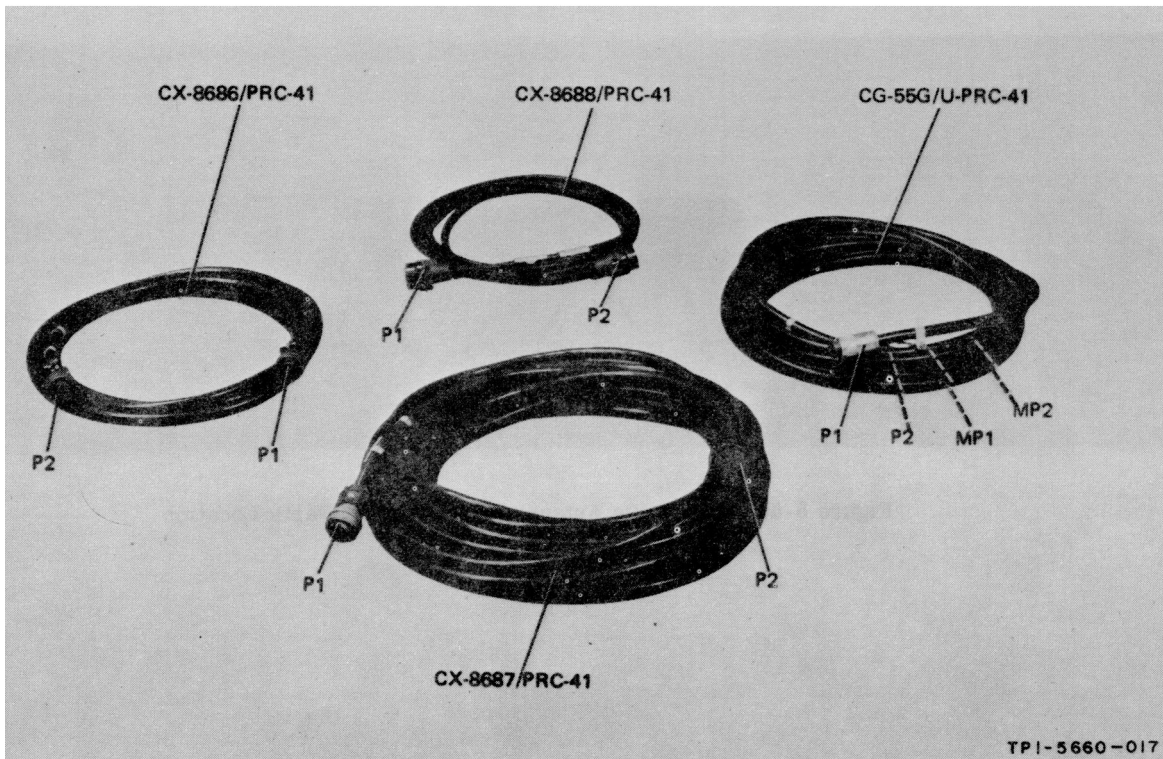

Figure 5-66. Cable Assemblies, Part Location

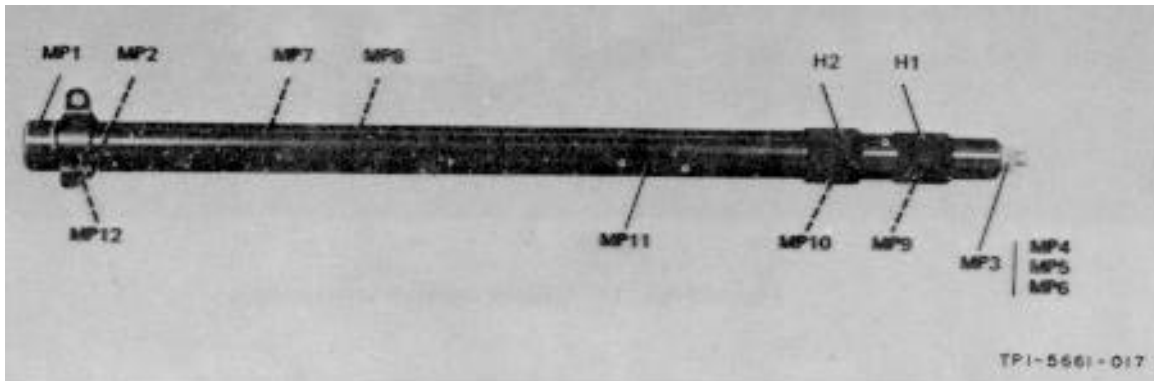

Figure 5-67. Mast AB-777/PRC-41, Parts Location

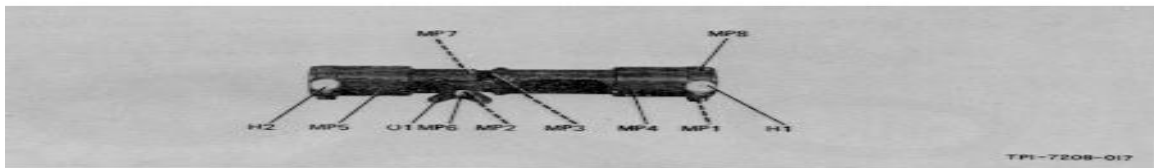

Figure 5-68. Adjustment Antenna Mast Adapter, Parts Location

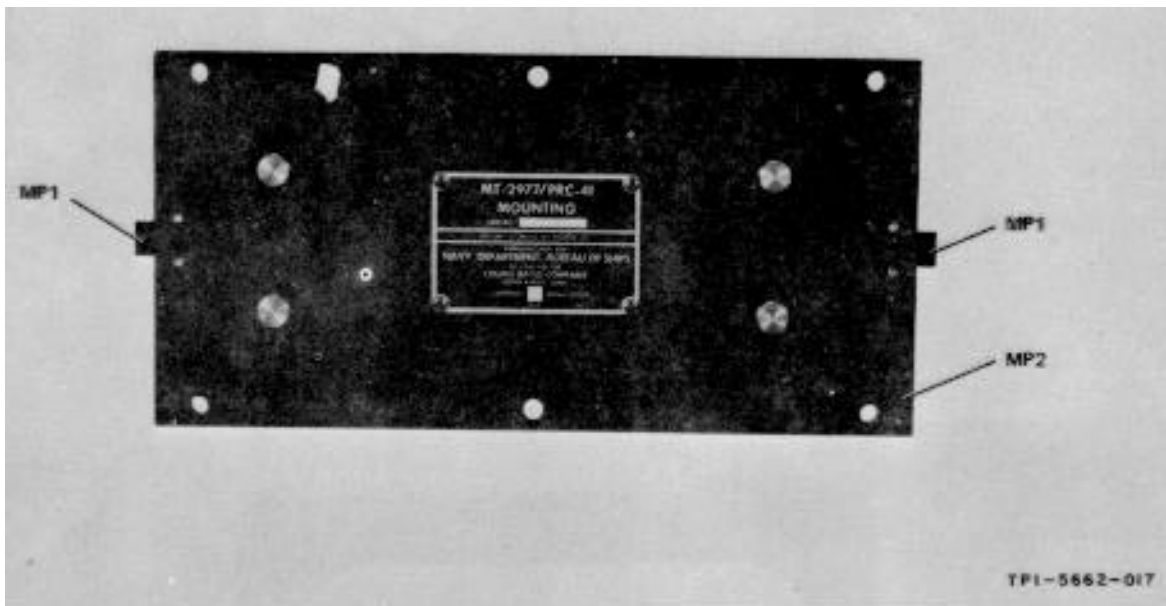

Figure 5-69. Mounting MT-2977/PRC-41, Parts Location

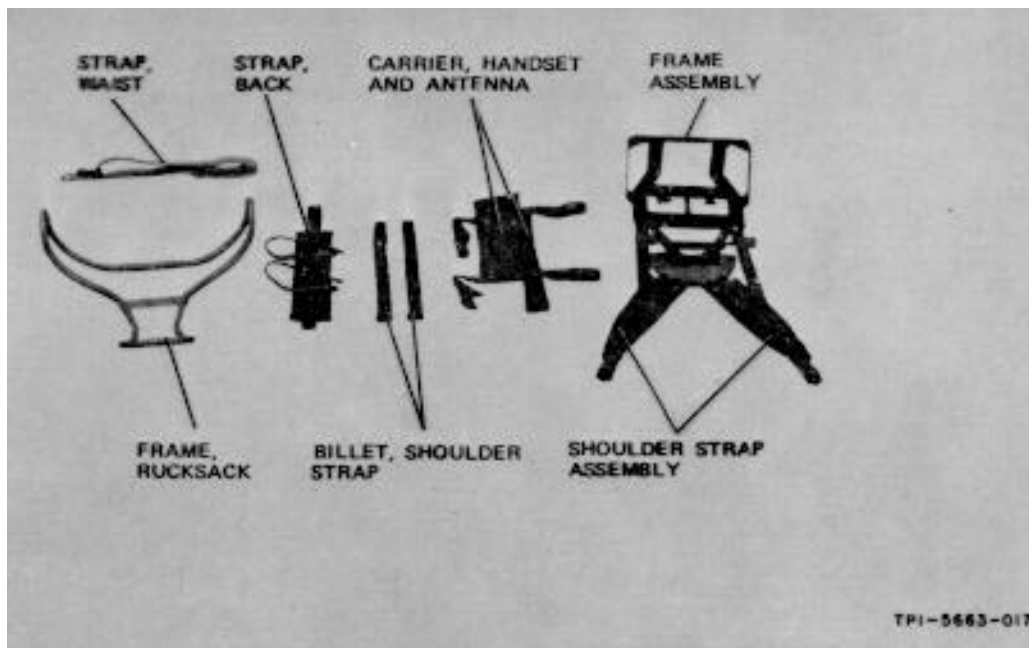

Figure 5-70. Rucksack Frame and Harness

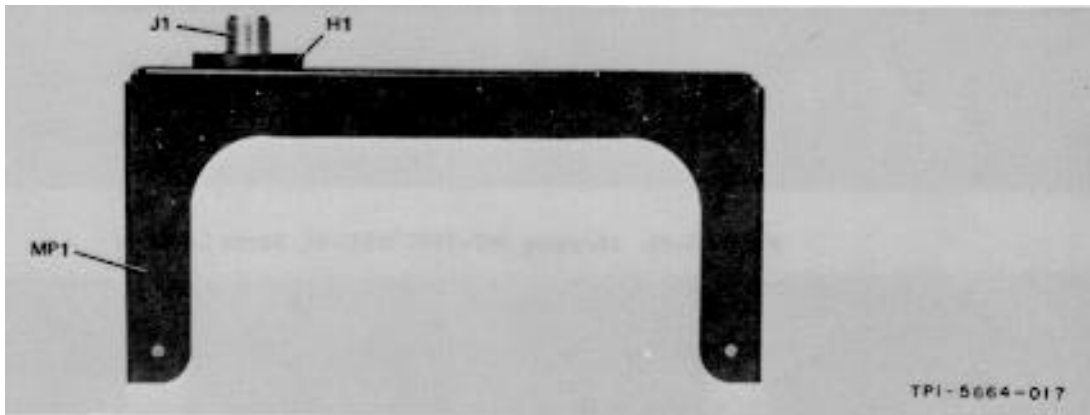

Figure 5-71. Antenna Mounting Bracket, Parts Location

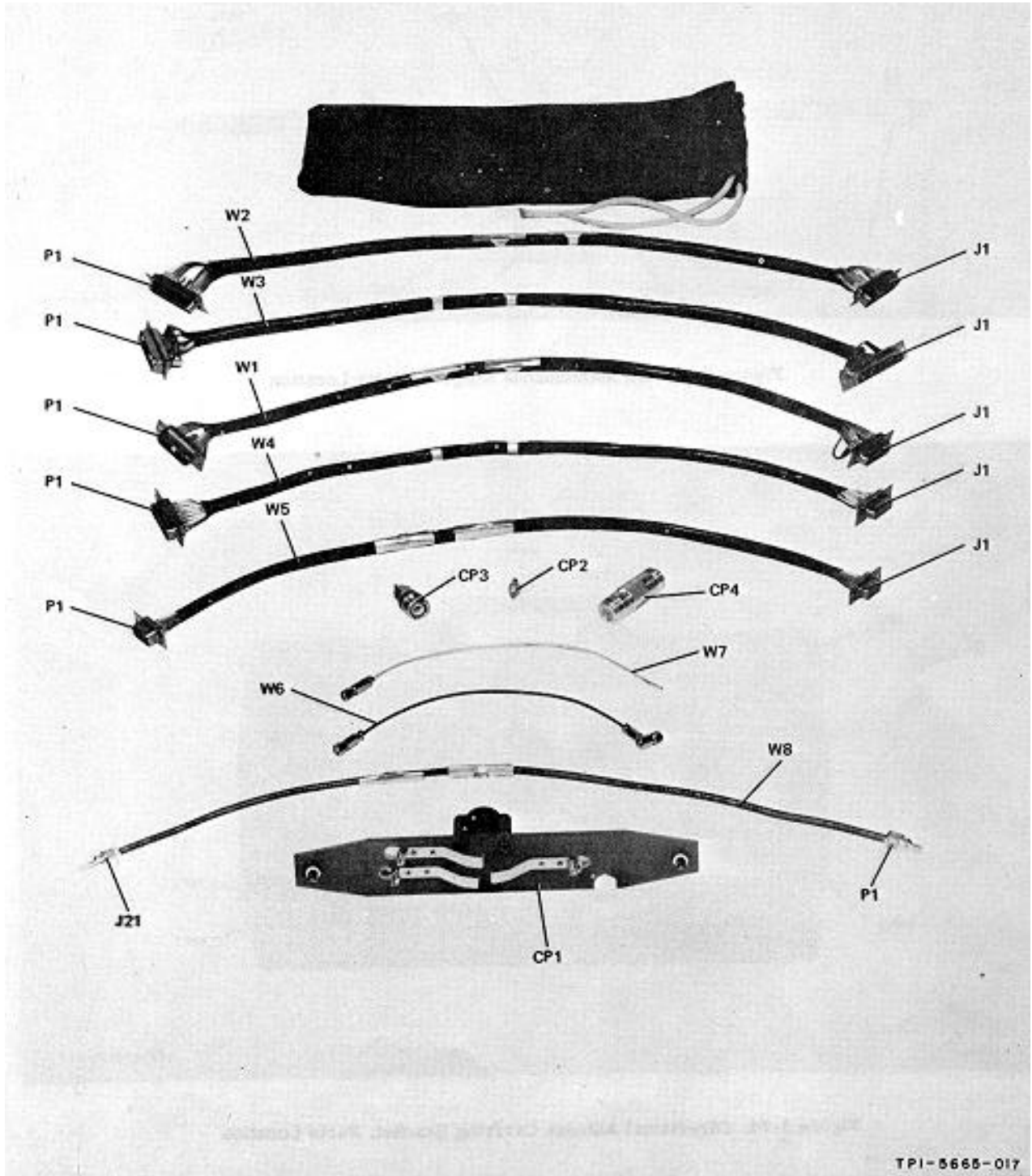

Figure 5-72. Maintenance Cable Set, Parts Location

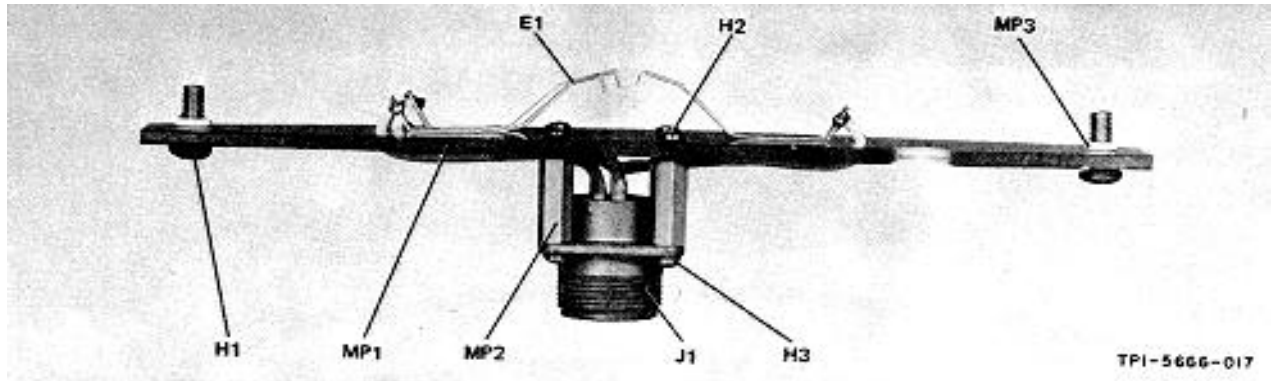

Figure 5-73. DC Maintenance Adapter, Parts Location

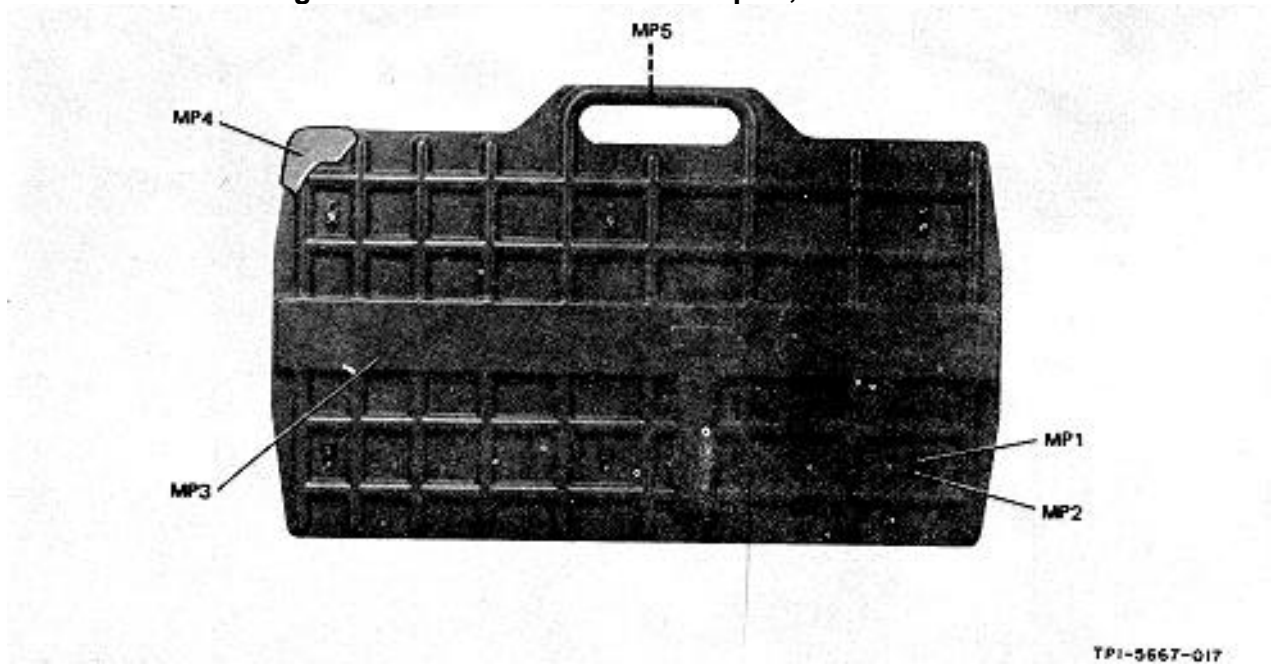
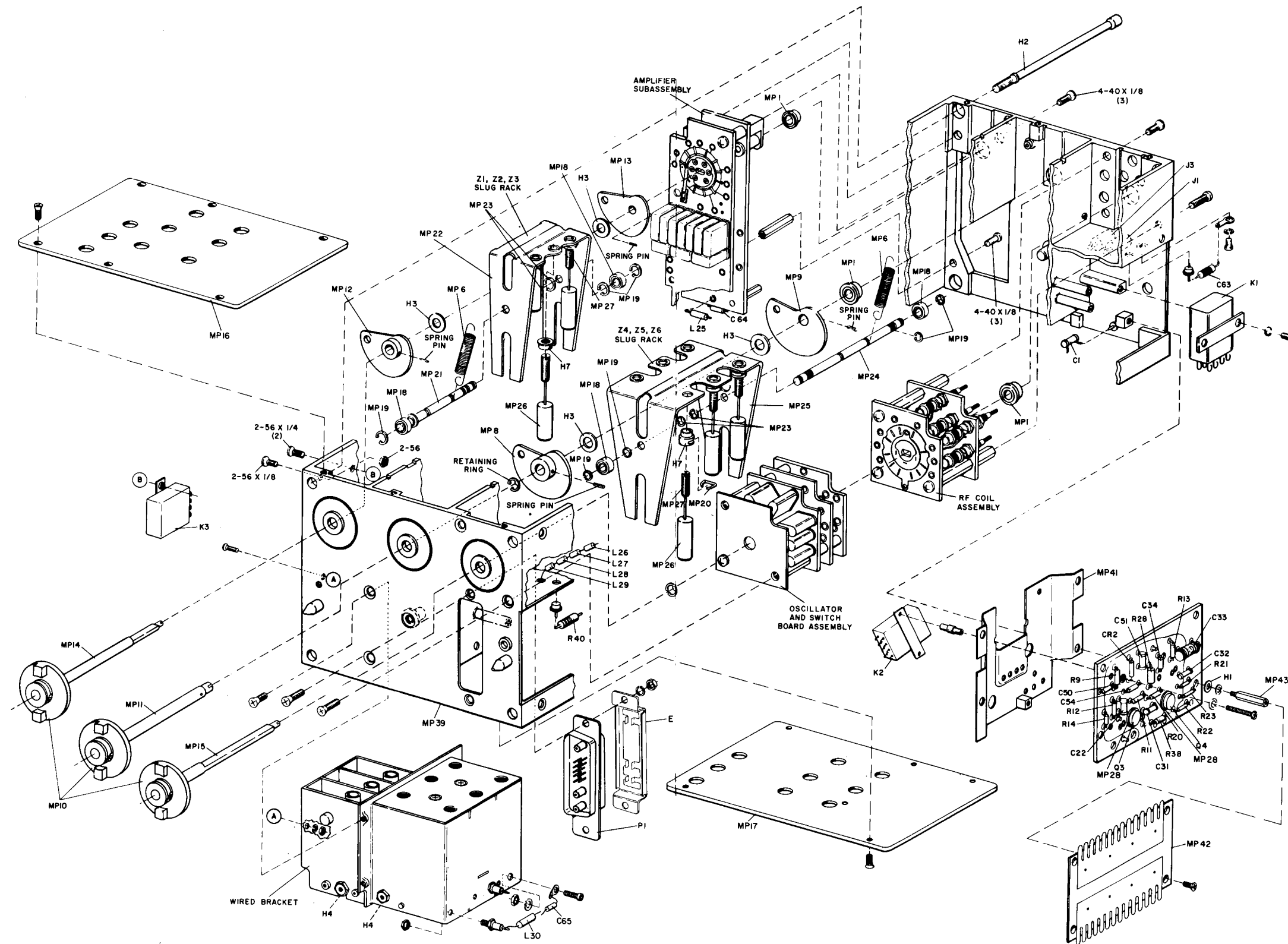

Figure 5-74. Directional Antenna Carrying Bracket, Parts Location



ORIGINAL

5-77, 5-78

Figure 5-75. 1<sup>st</sup> and 2<sup>nd</sup>. IF Amplifier Module, Exploded View

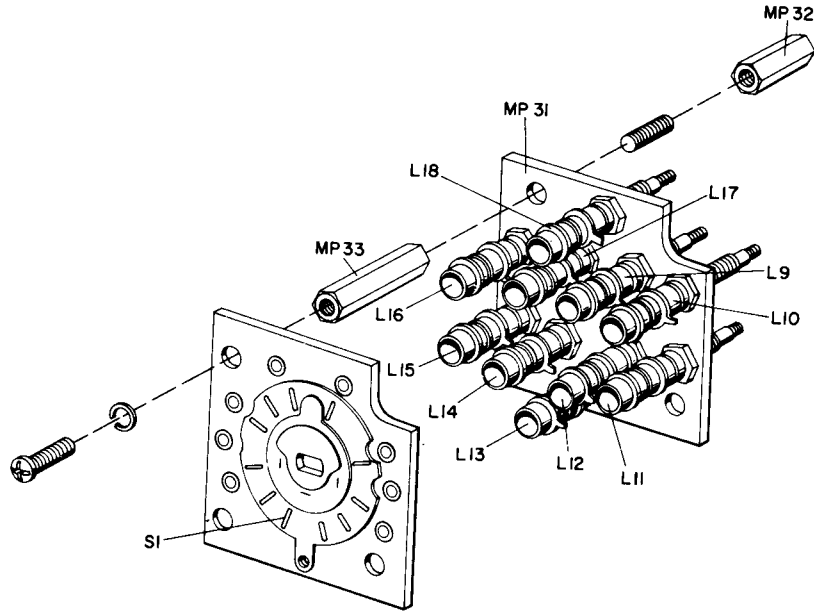

Figure 5-76. 1st and 2nd IF Amplifier Module, Oscillator and Switchboard Assembly, Exploded View

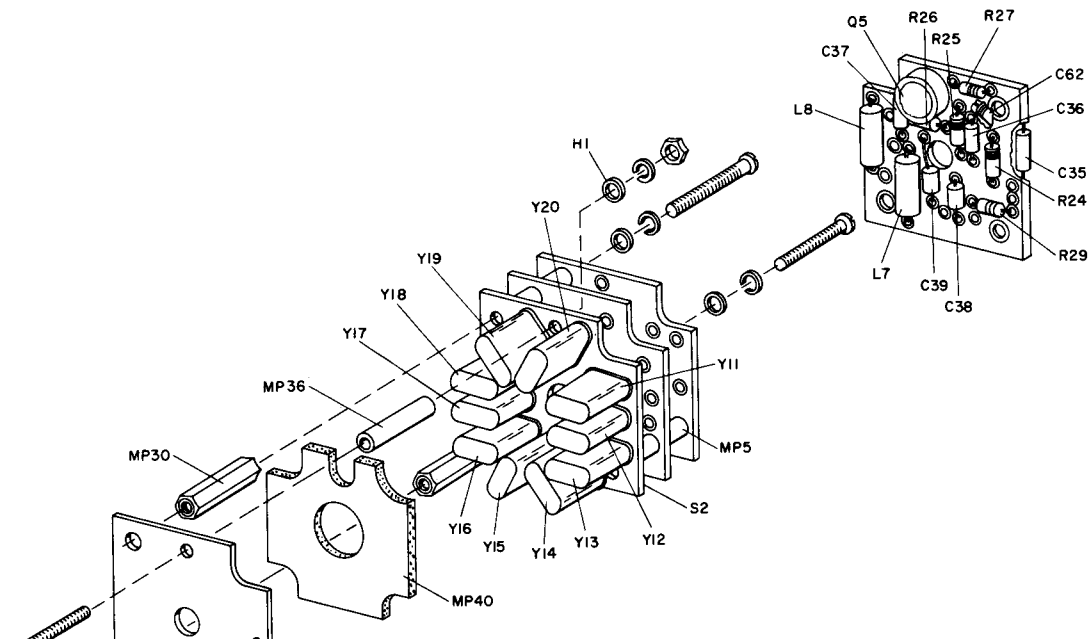

Figure 5-77. 1st and 2nd IF Amplifier Module, RF Coil Assembly, Exploded View

ORIGINAL

5-79, 5-80



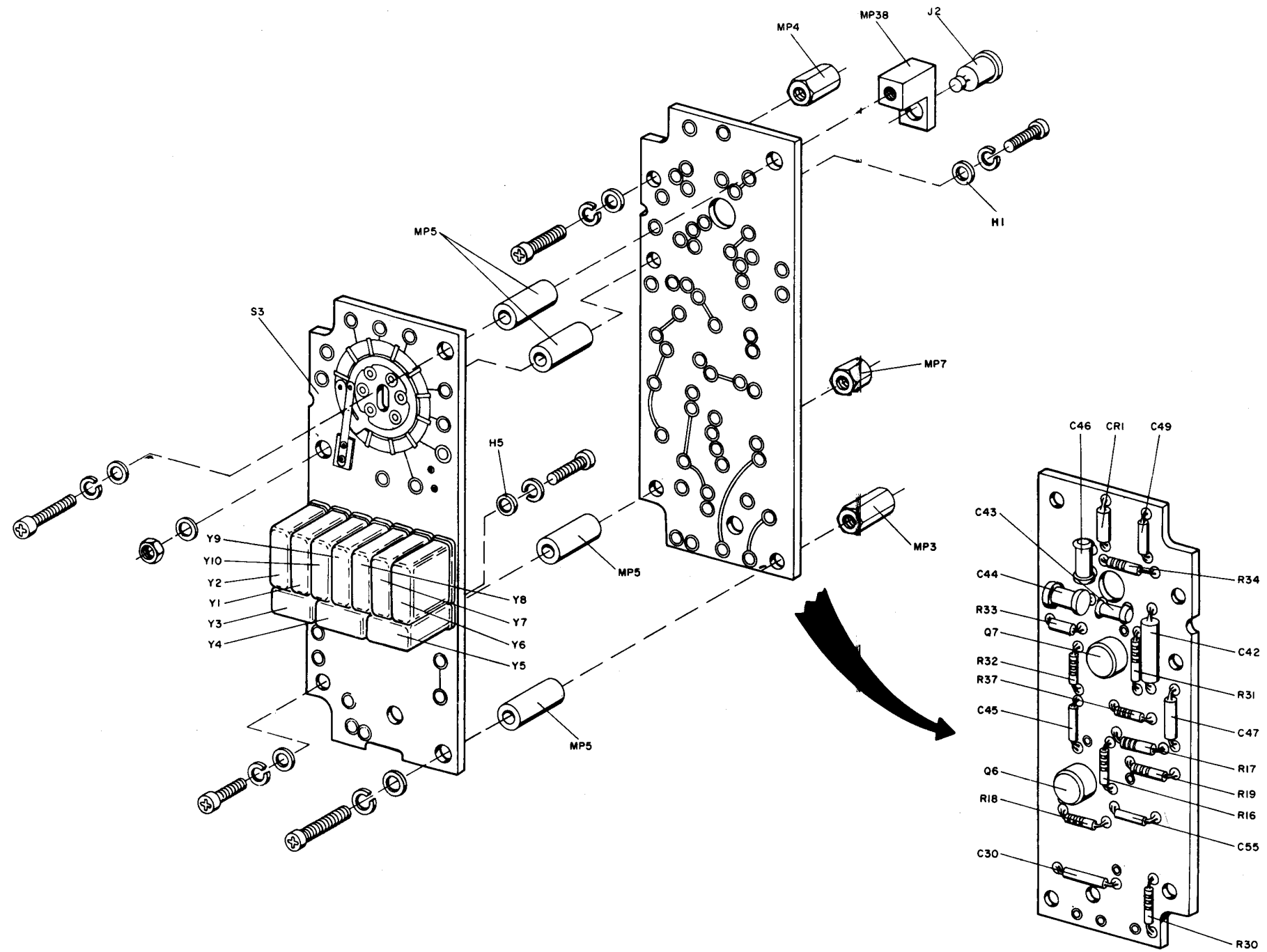
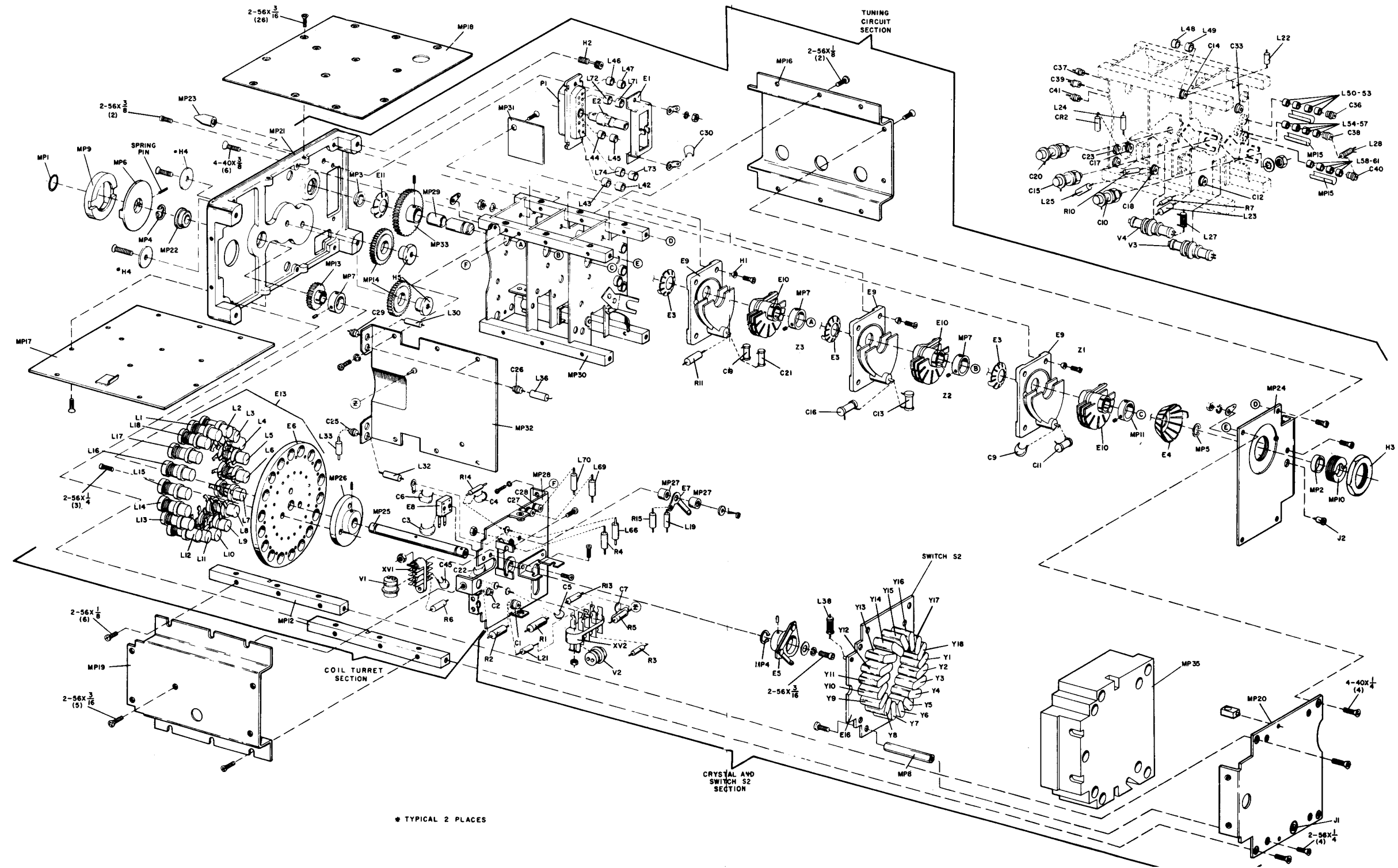

Figure 5-78. 1<sup>st</sup> and 2<sup>nd</sup> IF Amplifier Module, Amplifier Subassembly, Exploded View



\* TYPICAL 2 PLACES

Figure 5-79. Spectrum Generator Module, Exploded View

ORIGINAL

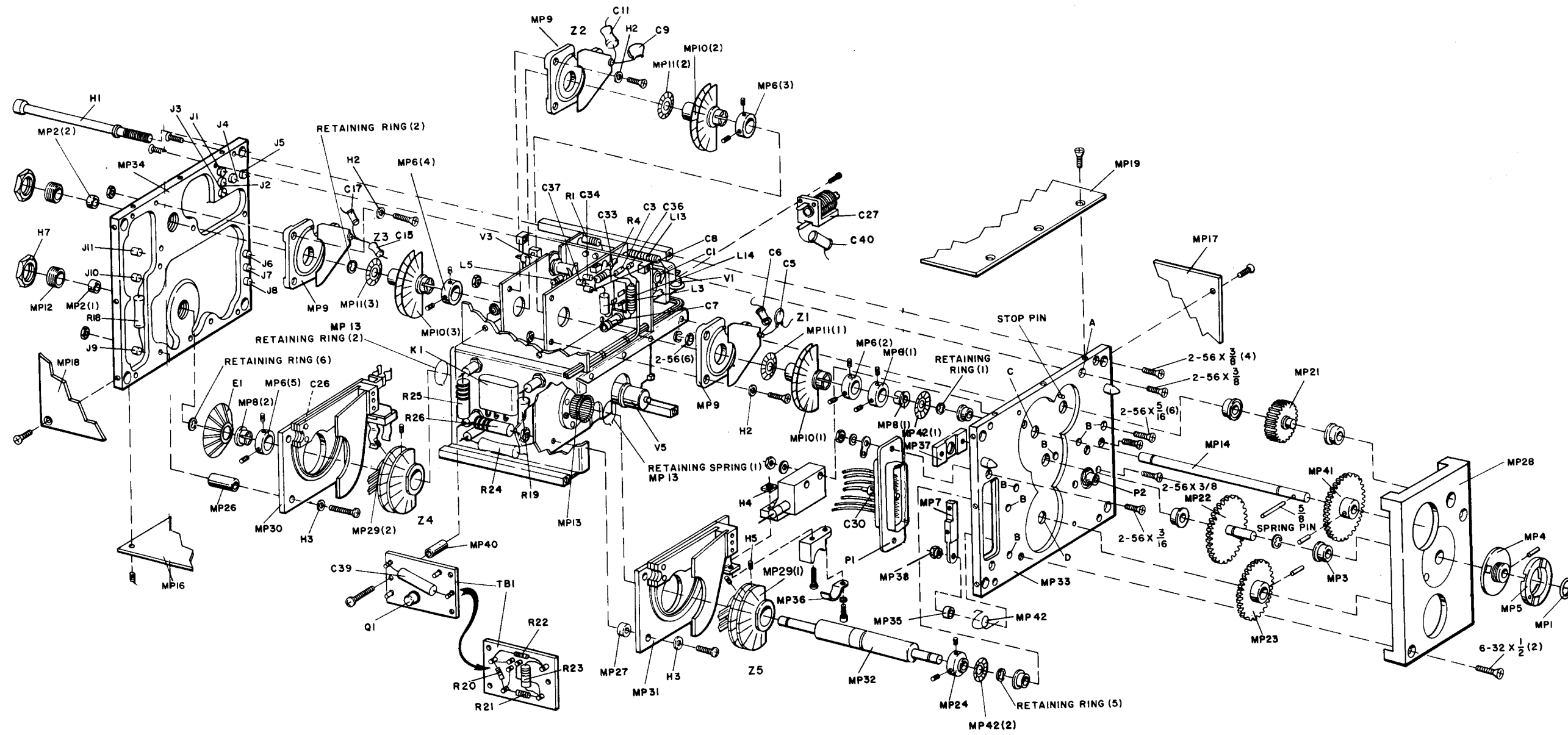

Figure 5-80. RF and Power Amplifier Module, Exploded View

Figure 5-81

NAVSHIPS 0967-872-5020  
TM-03816B-35/2  
TM11-5820-510-35-1

AN/PRC-41A  
MAINTENANCE

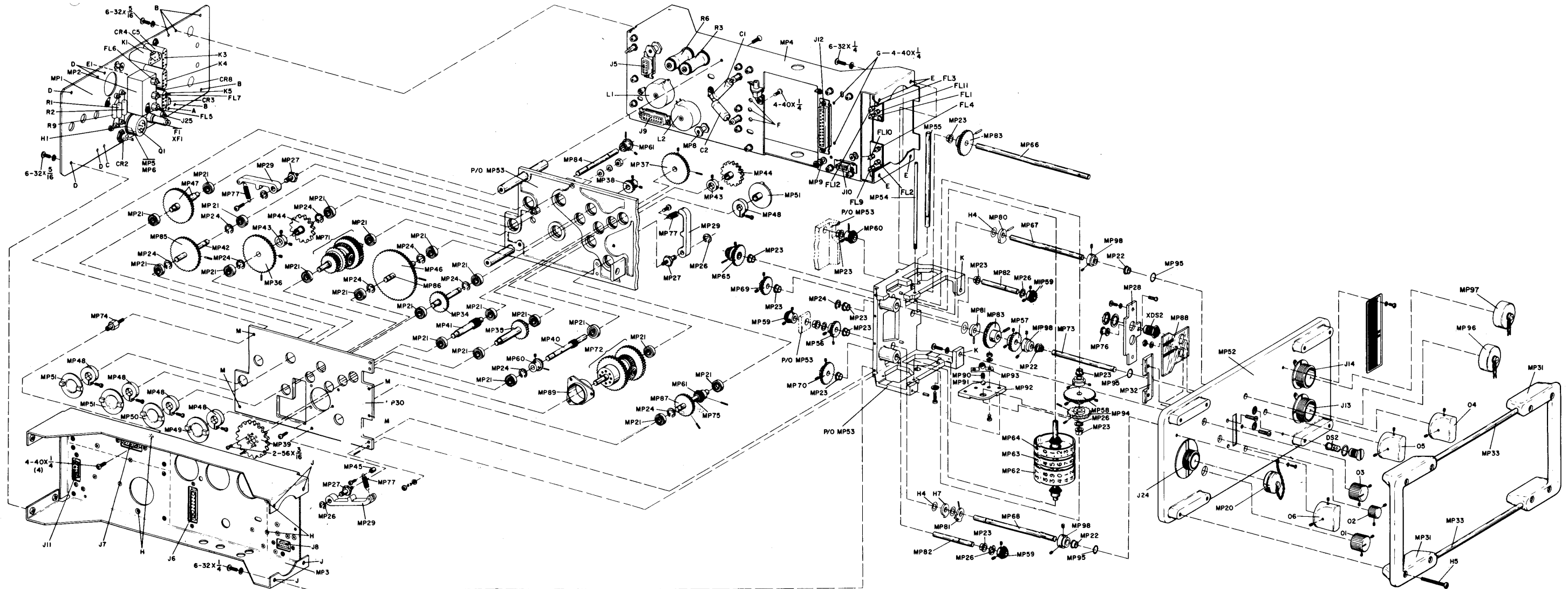

Figure 5-81. Radio Receiver-Transmitter RT-695A/PRC-41, Main Chassis, Exploded View

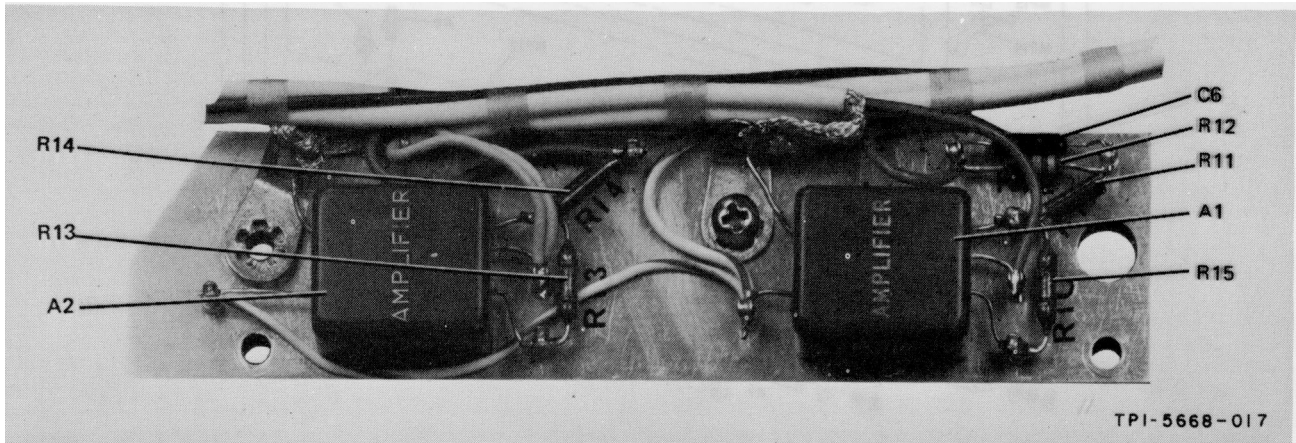

Figure 5-82. AF Amplifier Assembly (Buffer)

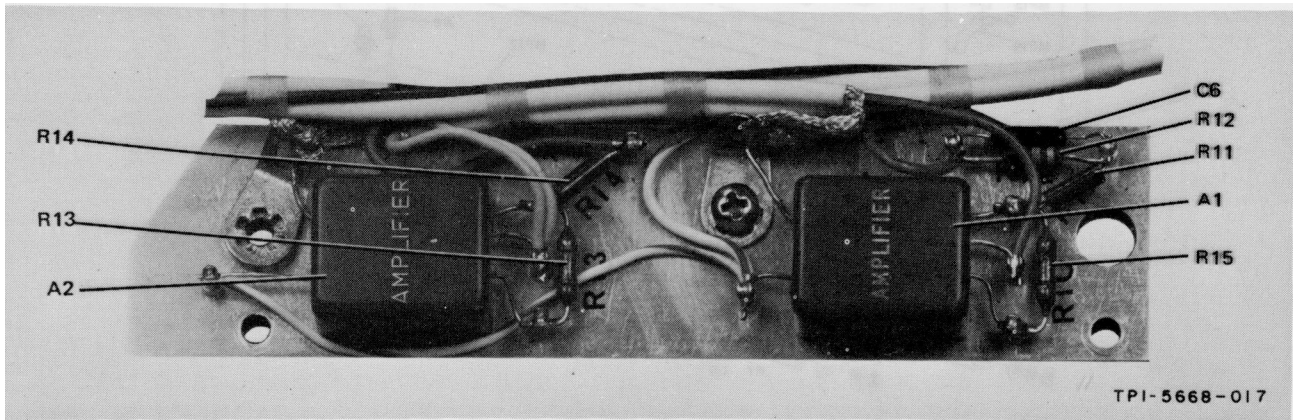

Figure 5-83. Connector and Filter Assembly

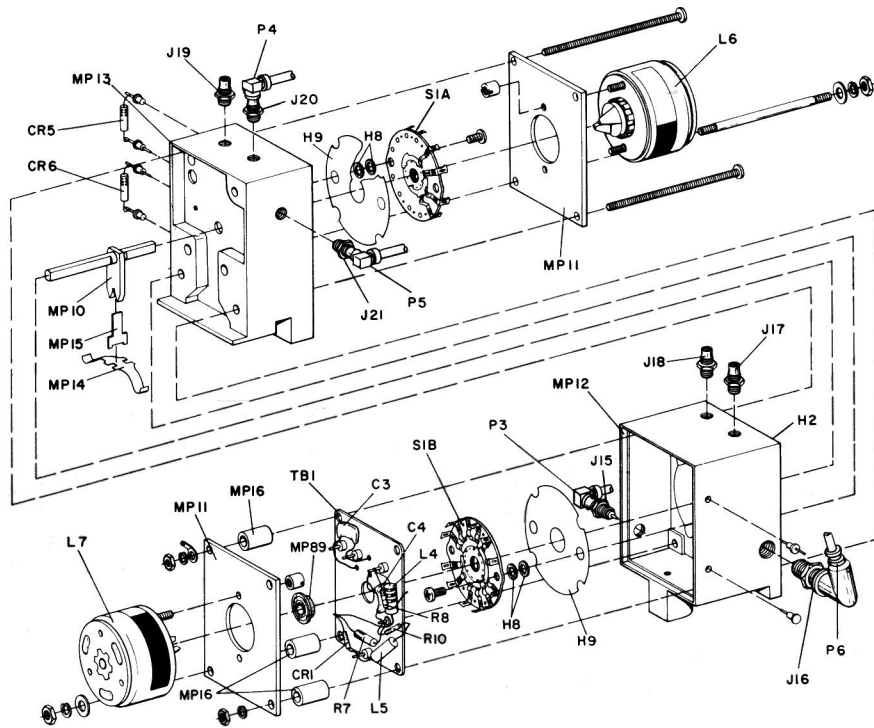

Figure 5-84. Receive-Transmit Switch, Exploded View

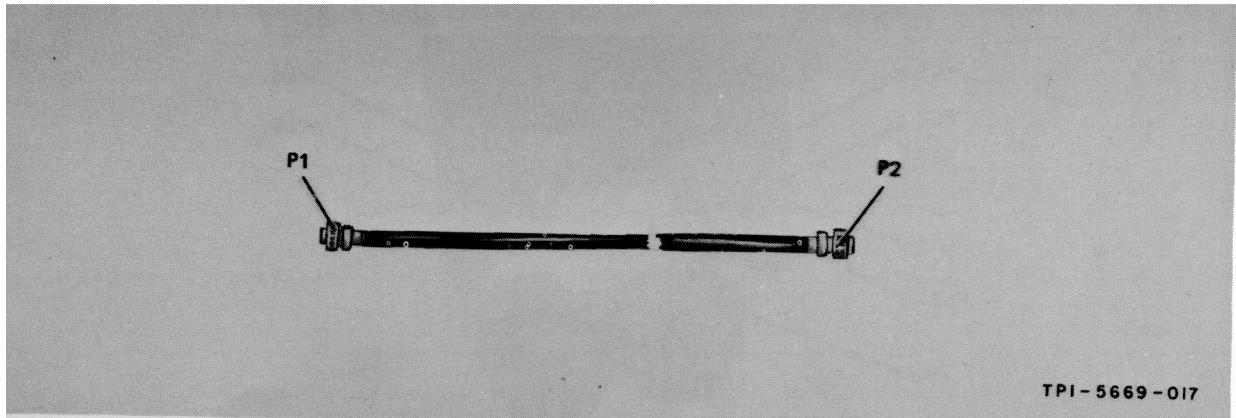
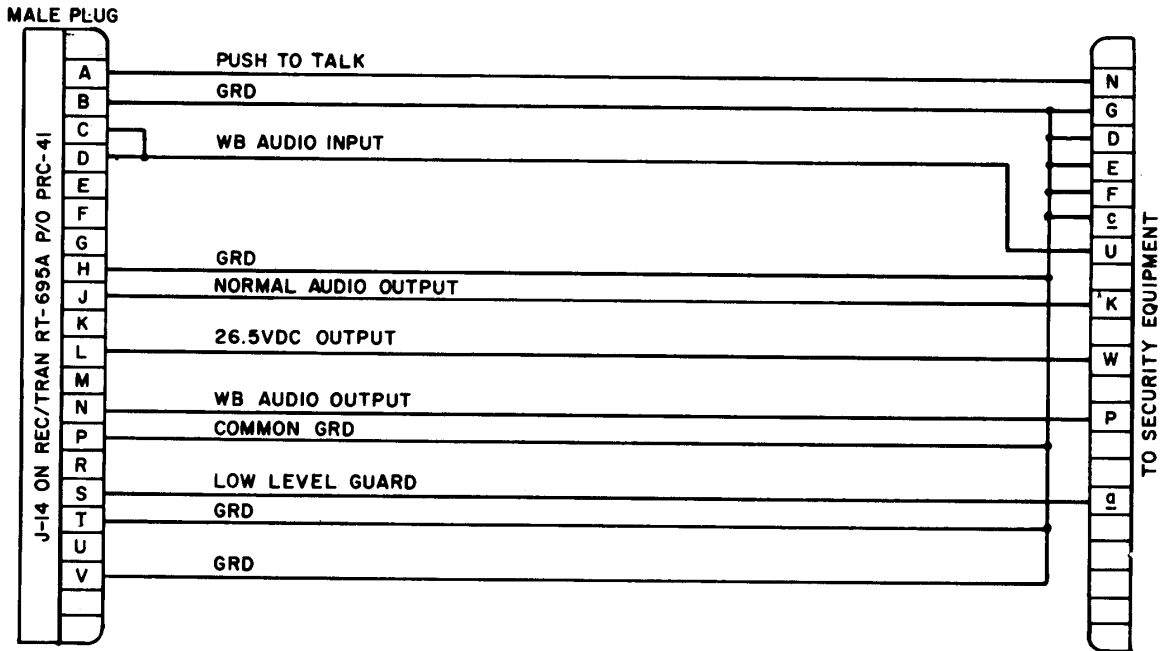
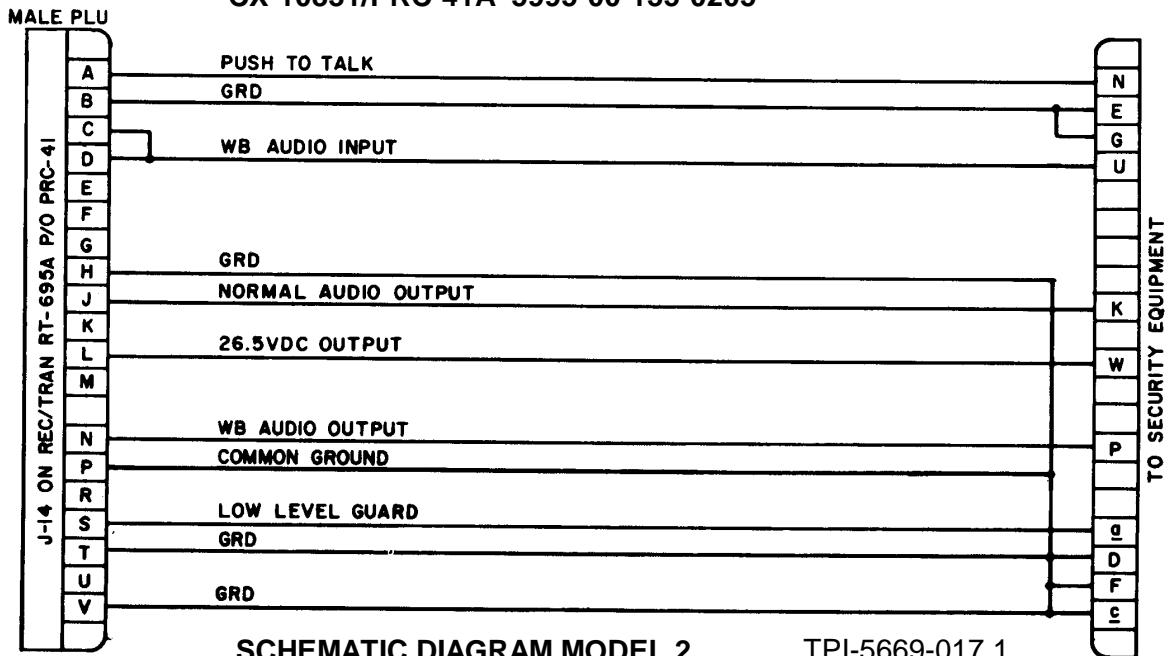

Figure 5-85. Special Purpose Electrical Cable Assembly CX-10831/PRC-41A



**SCHMATIC DIAGRAM MODEL 1**  
CX-10831/PRC-41A 5995-00-135-0205



**SCHMATIC DIAGRAM MODEL 2**  
CX-10831/PRC-41A 5995-00-135-0205

TPI-5669-017.1

Figure No. 5-86.1. Schematic Diagrams, Model 1 and Model 2, CX-10831/PRC-41A

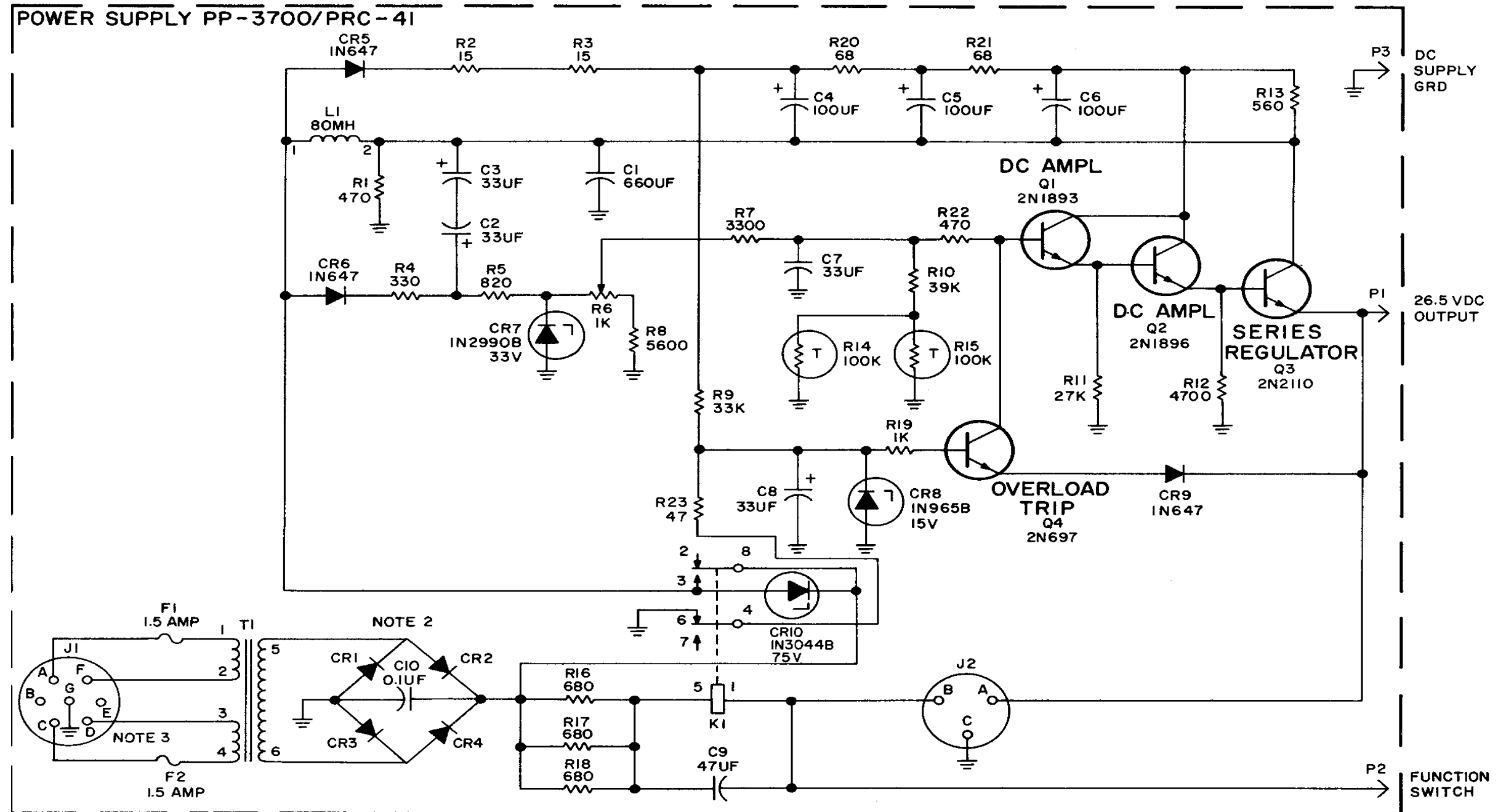

NOTES:

1. UNLESS OTHERWISE INDICATED ALL RESISTANCE VALUES ARE IN OHMS.
2. CR1 THRU CR4 ARE IN249B.

3. POWER ELECTRIC CABLE ASSEMBLY CX-8687/PRC-41 PLUG P1.

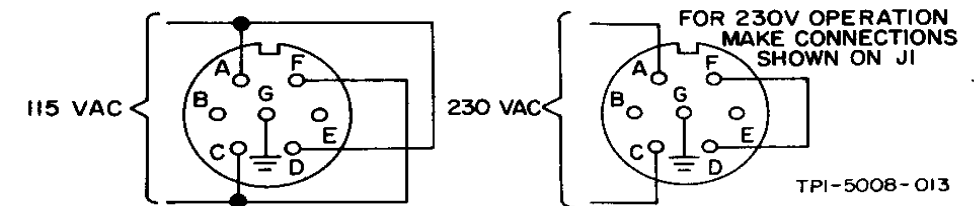

TPI-5008-013

Figure 5-86. Power Supply PP-3700/PRC-41, Schematic Diagram



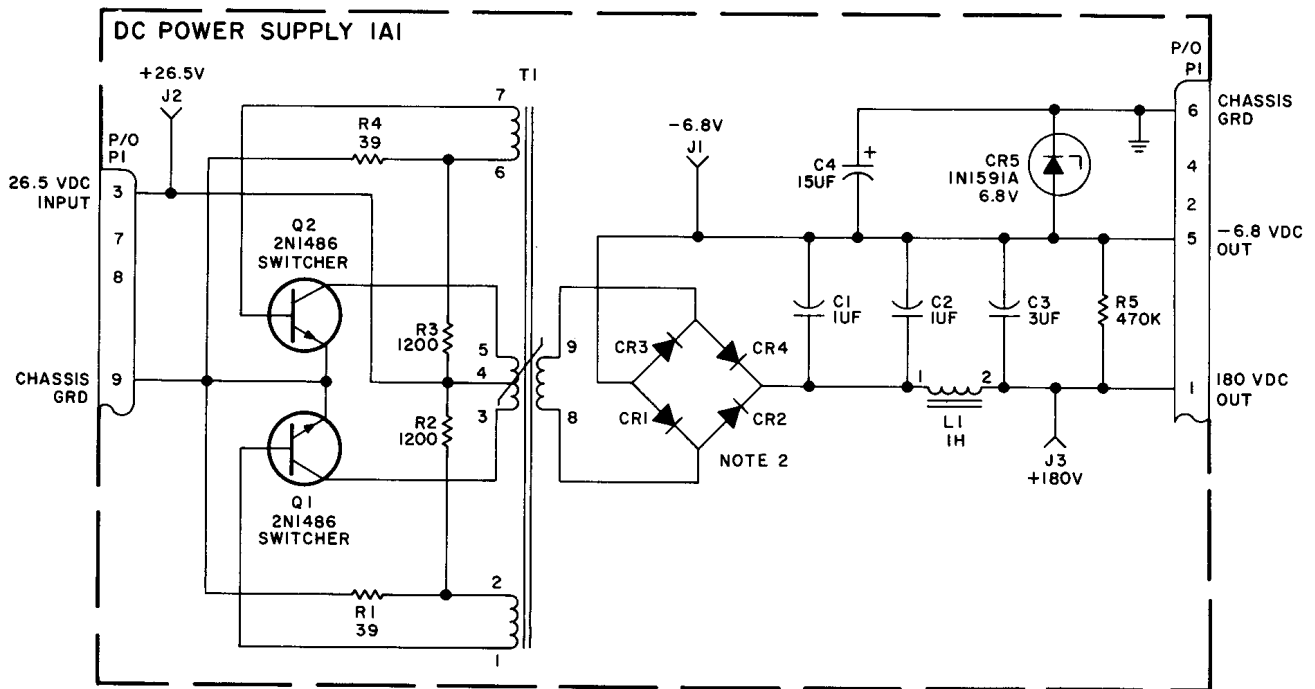

NOTES:  
 1. UNLESS OTHERWISE INDICATED ALL RESISTANCE  
 VALUES ARE IN OHMS.  
 2. CR1 THRU CR4 ARE TYPE IN649.

TPI-5000-013

Figure 5-87. DC Power Supply 1A1, Schematic Diagram

ORIGINAL 5-89, 5-90

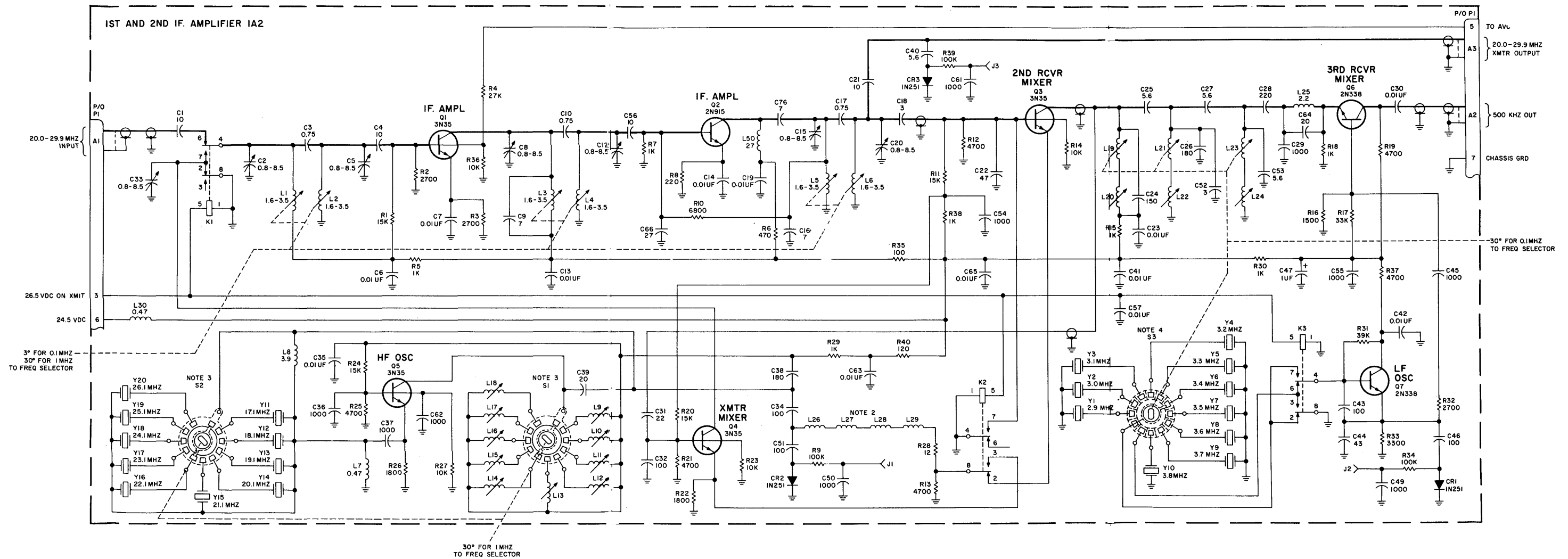

NOTES:

1. UNLESS OTHERWISE INDICATED;  
ALL RESISTANCE VALUES ARE IN OHMS.  
ALL CAPACITANCE VALUES ARE IN PICOFARADS, AND
2. L26 THRU L29 ARE FERRITE BEADS.
3. FRONT AND BACK ROTORS ARE ELECTRICALLY CONNECTED  
IN POSITION SHOWN, FIRST IF. IS TUNED TO 25 MHZ.
4. FRONT AND BACK ROTORS ARE SEPERATE.  
FRONT ROTOR FOR TRANSMIT; BACK ROTOR  
FOR RECEIVE. IN POSITION SHOWN, SECOND  
IF. IS TUNED FOR 2.9 MHZ.

Figure 5-88. 1<sup>st</sup> and 2<sup>nd</sup> IF Amplifier 1A2, Schematic Diagram

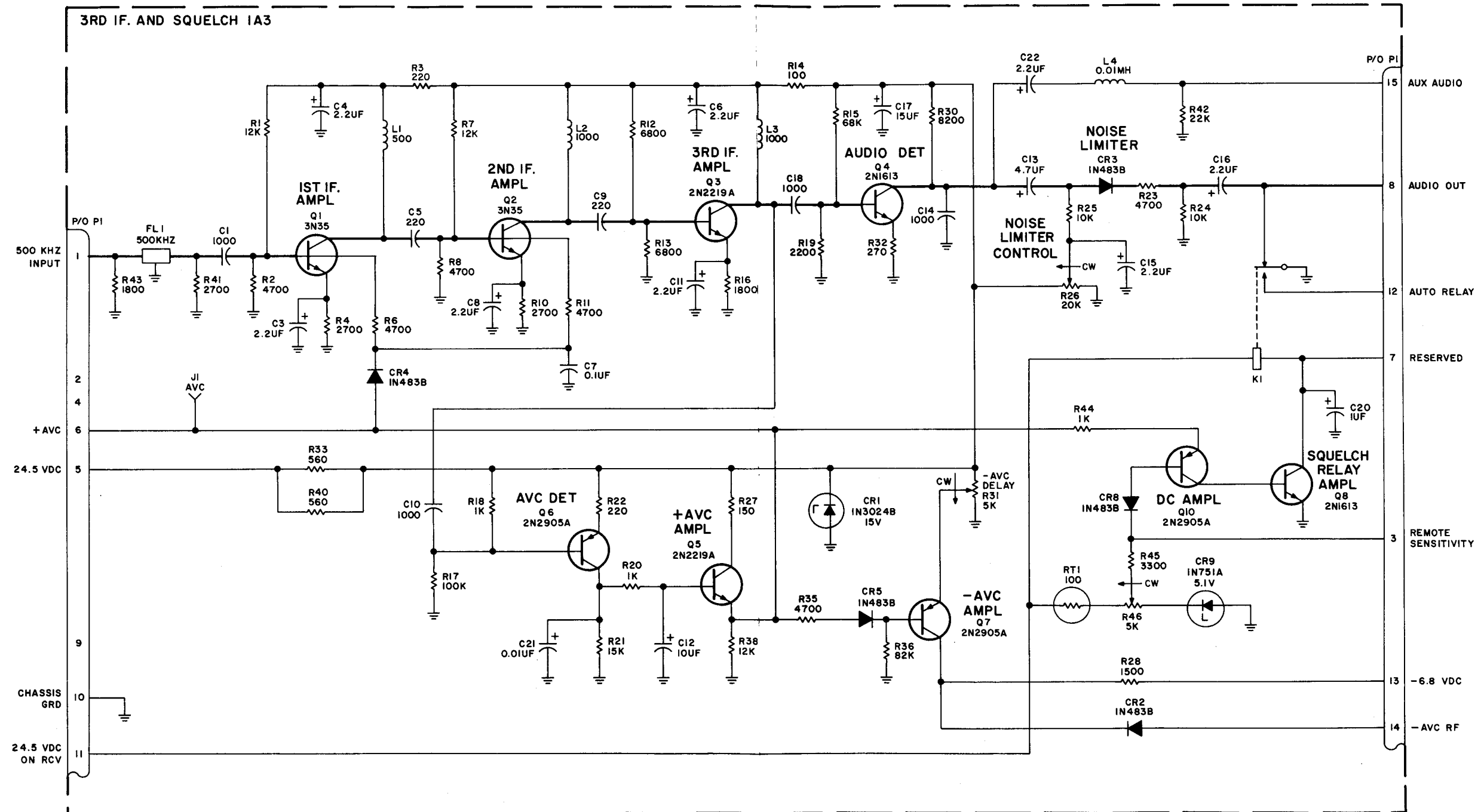

NOTE:  
UNLESS OTHERWISE INDICATED, ALL RESISTANCE VALUES  
ARE IN OHMS, ALL CAPACITANCE VALUES ARE IN PICOFARADS,  
AND ALL INDUCTANCE VALUES ARE IN MICROHENRYS.

Figure 5-89. 3<sup>rd</sup> IF and Squelch 1A3, Schematic Diagram

TPI-5003-014

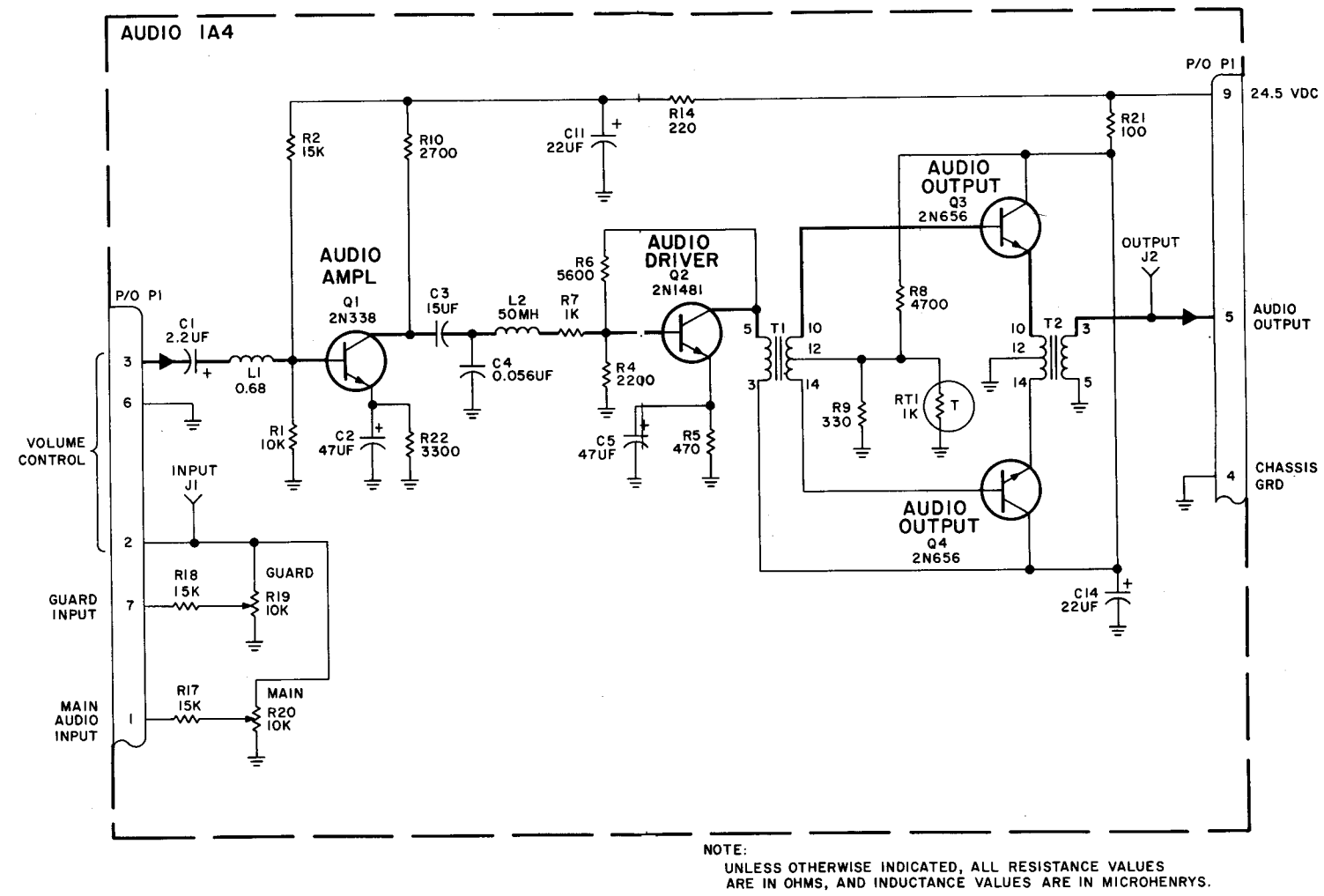

TPI-5002-013

Figure 5-90. Audio 1A4, Schematic Diagram

ORIGINAL 5-95, 5-96

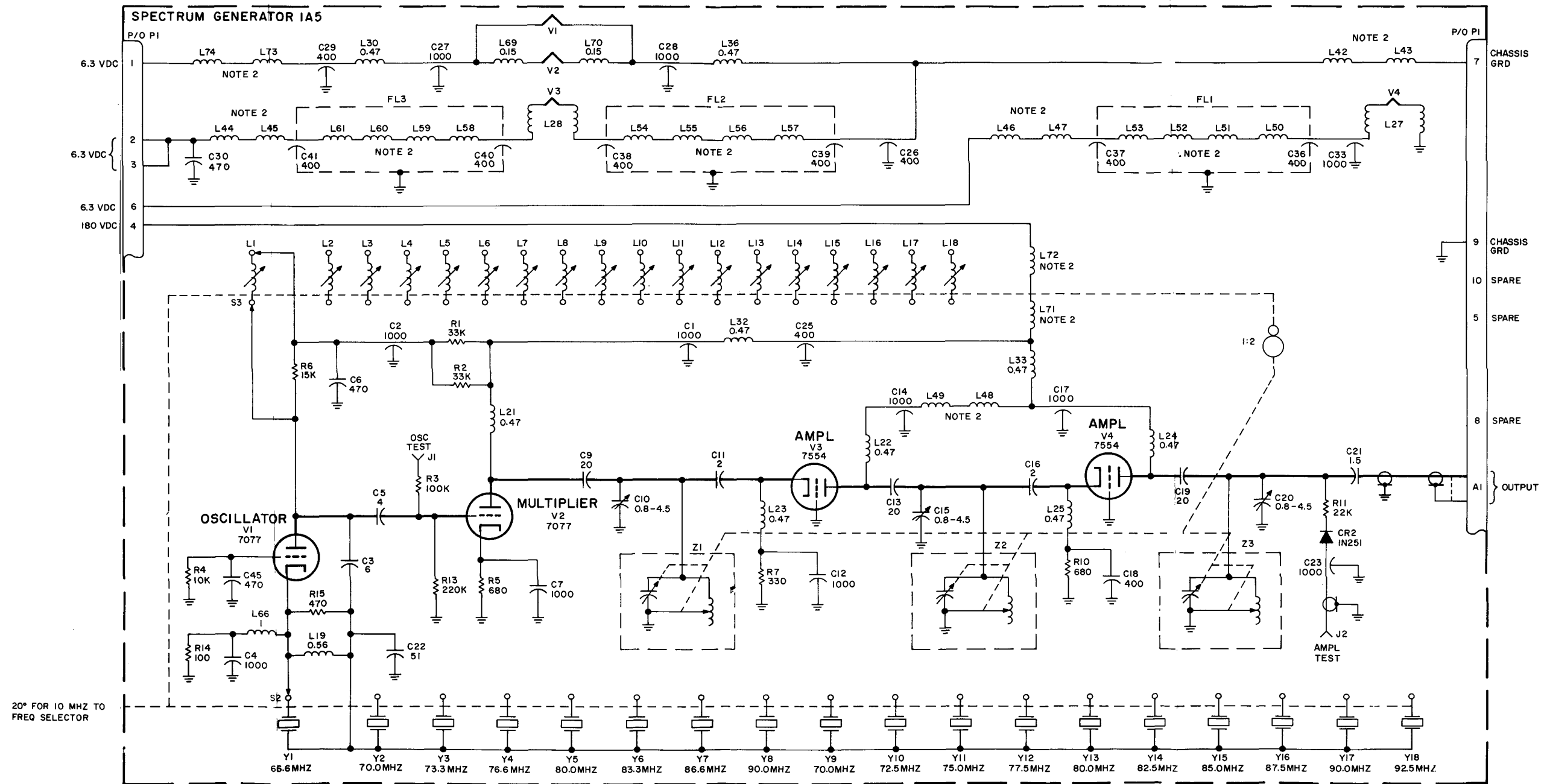

NOTES:

1. UNLESS OTHERWISE INDICATED; ALL RESISTANCE VALUES ARE IN OHMS, ALL CAPACITANCE VALUES ARE IN PICO FARADS, AND ALL INDUCTANCE VALUES ARE IN MICROHENRYS.
2. L42 THRU L61 AND L71 THRU L74 ARE FERRITE BEADS.

Figure 5-91. Spectrum Generator 1A5, Schematic Diagram

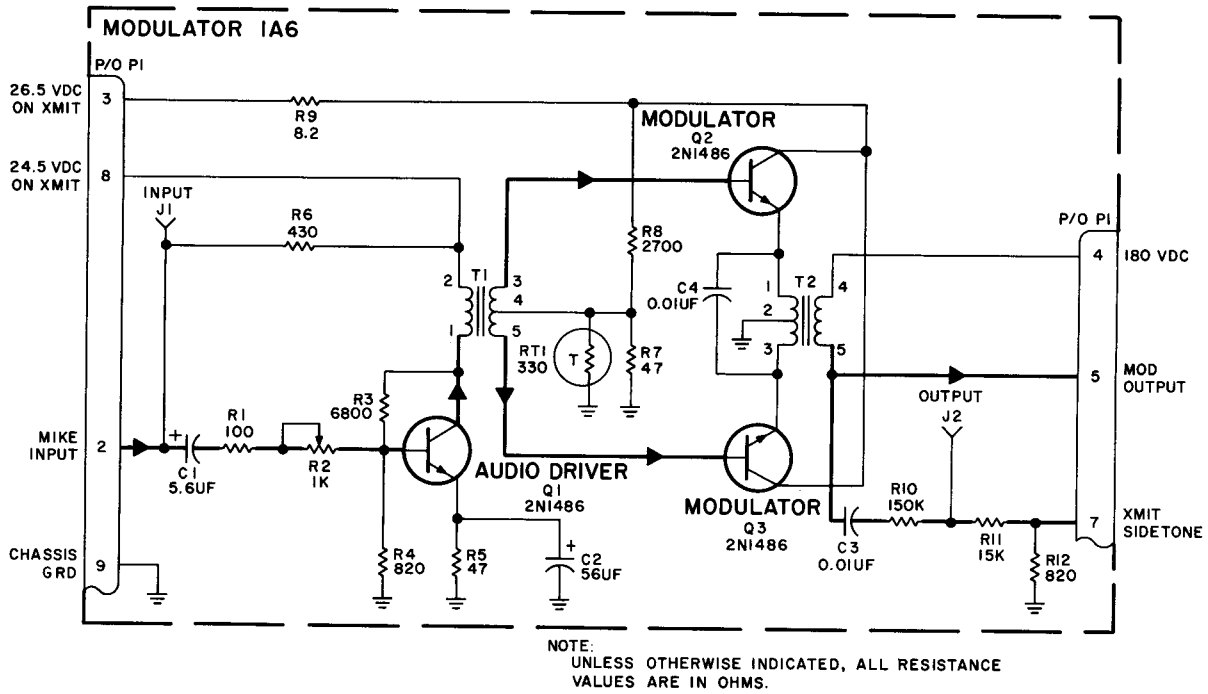

TPI-5001-013

Figure 5-92. Modulator 1A6, Schematic Diagram

ORIGINAL 5-99, 5-100

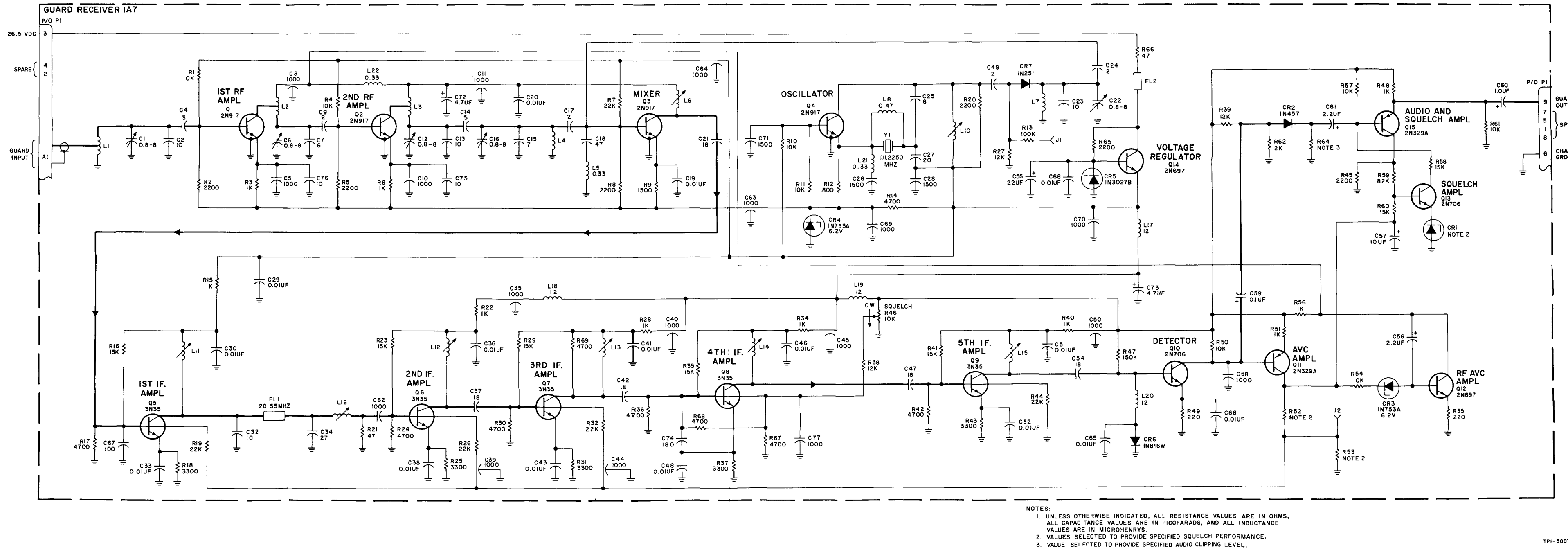

Figure 5-93. Guard 1A7, Schematic Diagram

ORIGINAL

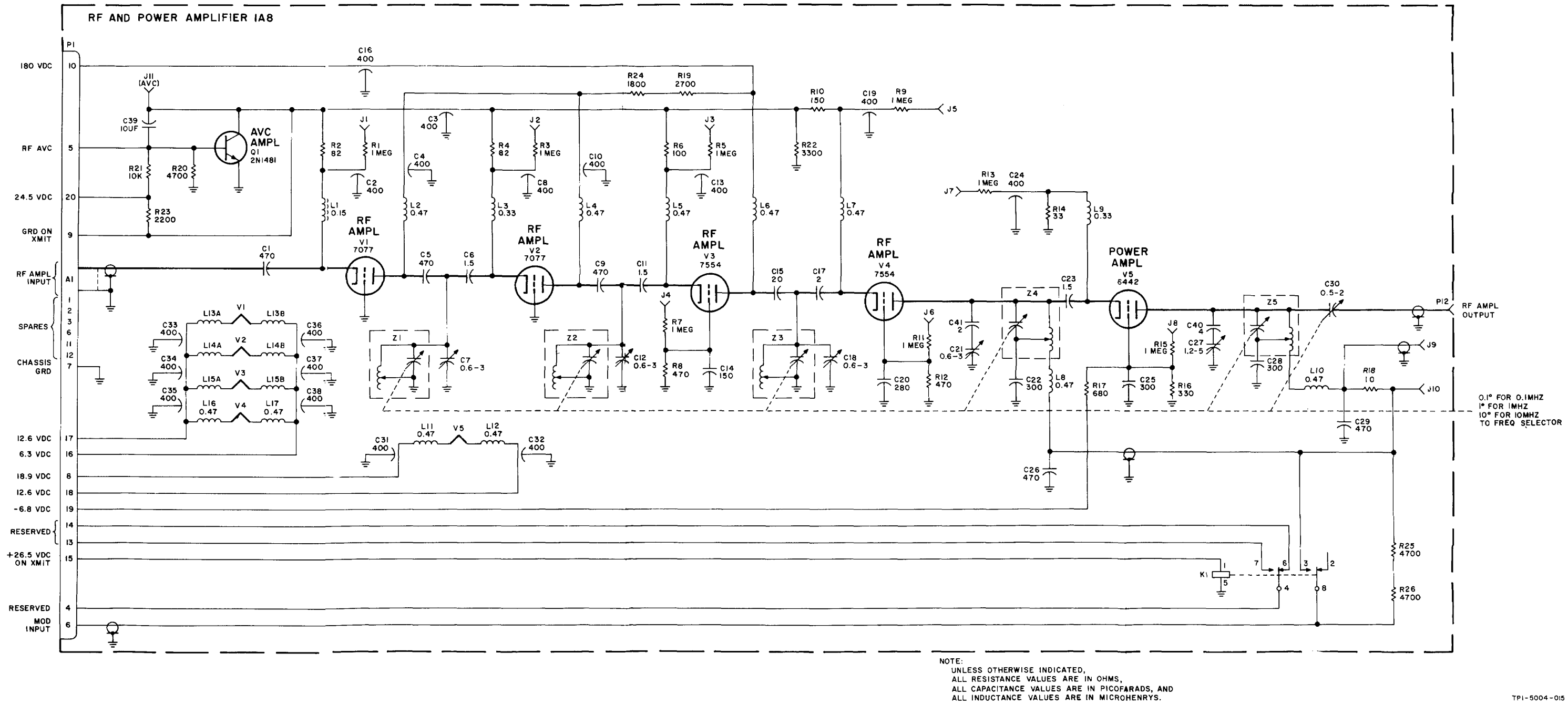

Figure 5-94. RF and Power Amplifier 1A8, Schematic Diagram



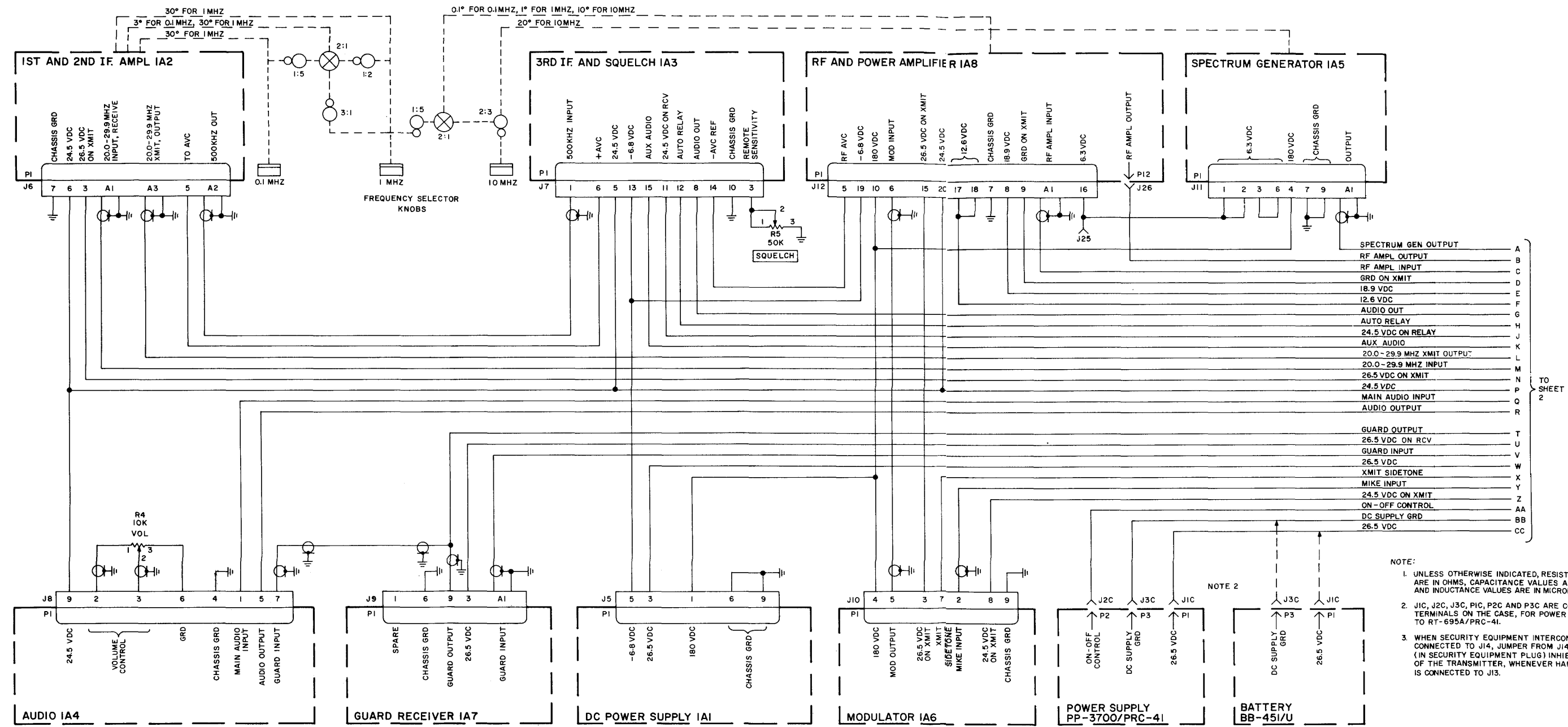

Figure 5-95. Radio Set AN/PRC-41-A, Interconnection Diagram (sheet 1 of 2)

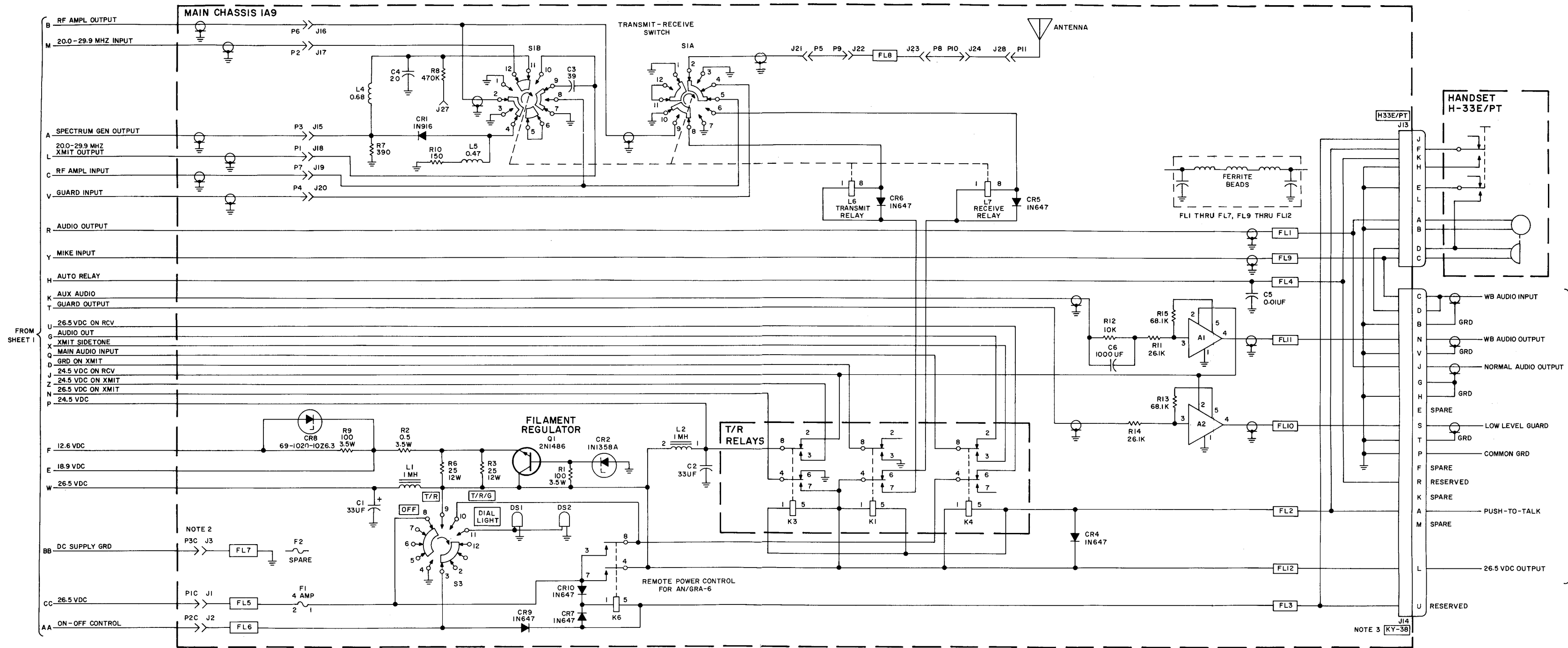

Figure 5-95. Radio Set AN/PRC-41A, Interconnection Diagram (sheet 2 of 2)

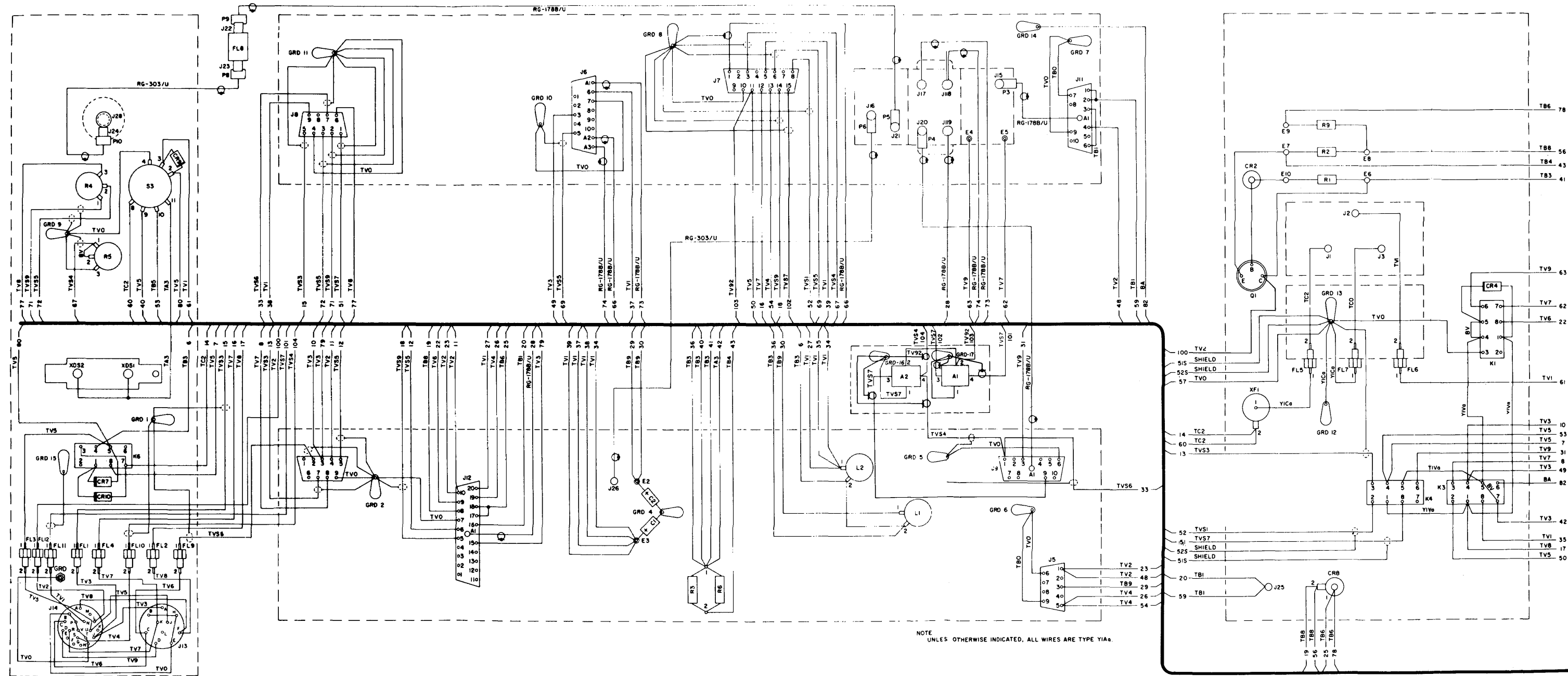

Figure 5-96. Radio Receiver-Transmitter RT-695A/PRC-41, Main Chassis, Wiring Diagram

SIZE OF WIRE		COVERING OF WIRE	COLOR CODE	
CODE	SIZE		CODE	TYPE
A	No. 22AWG			
B	No. 20		1	Brown
C	No. 18		2	Red
D	No. 16		3	Orange
E	No. 14		4	Yellow
F	No. 12		5	Green
G	No. 10		6	Blue
H	No. 8		7	Violet
J	No. 6		8	Gray (Slate)
K	No. 4		9	White
L	No. 2		a	Clear
M	No. 1		b	Tan
N	No. 0		c	Pink
P	No. 00		d	Maroon
Q	No. 000		e	Light Green
R	No. 0000	S Shielded	f	Light Blue
T	No. 28			
V	No. 26	S J Shielded		
W	No. 24	&		
X	No. 19	Jacket		
Y	No. 30			
Z				

Figure 5-97. Electrical Wire Code

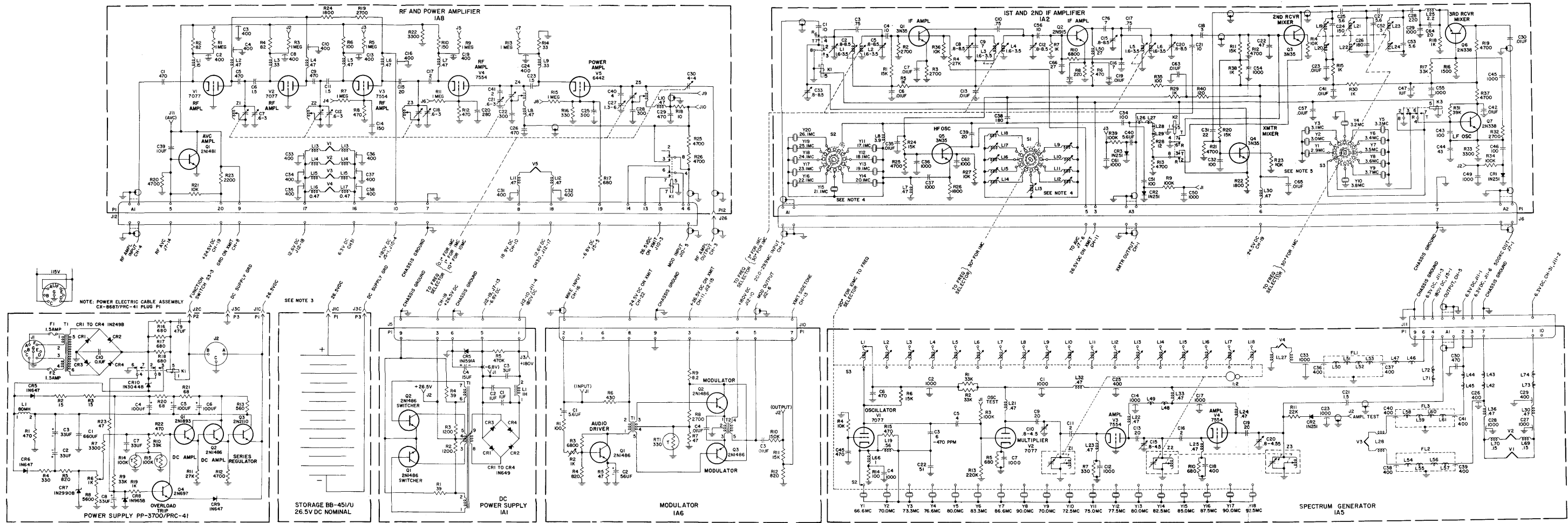

Figure 5-98. Radio Set AN/PRC-41A, Schematic Diagram (sheet 1 of 3)

ORIGINAL

Figure 5-98

NAVSHIPS 0967-872-5020  
TM-03816B-35/2  
TM 11-5820-510-35-1

AN/PRC-41A  
MAINTENANCE

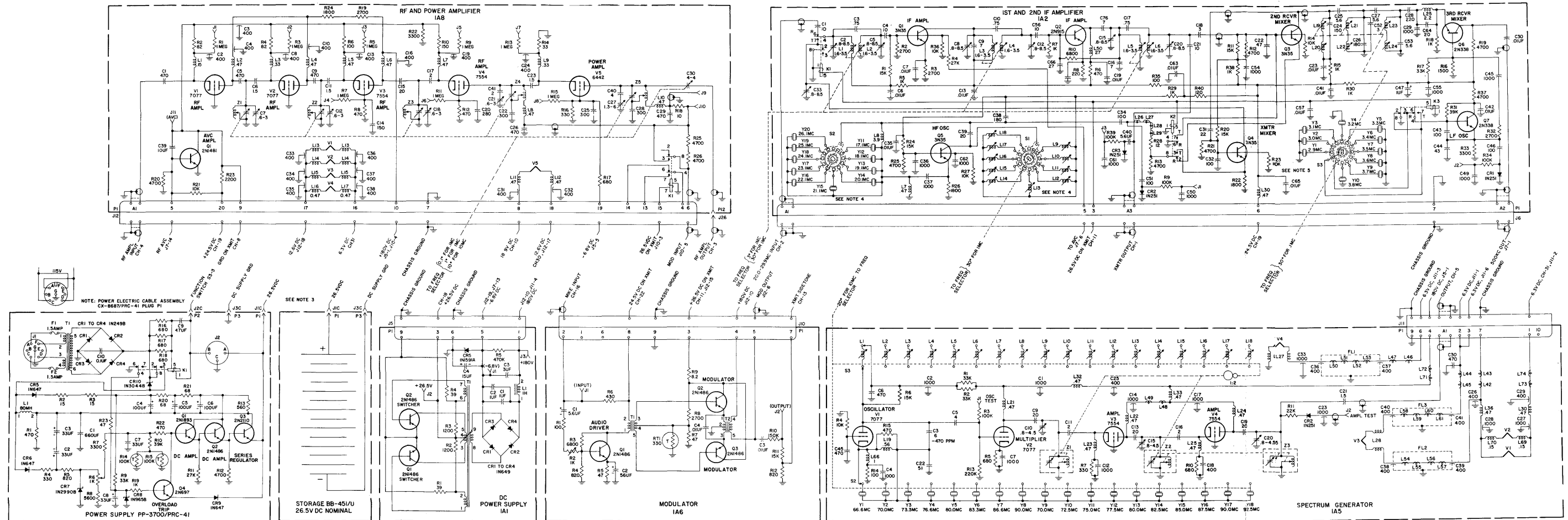

Figure 5-98. Radio Set AN/PRC-41A, Schematic Diagram (sheet 1 of 3)  
5-110

ORIGINAL

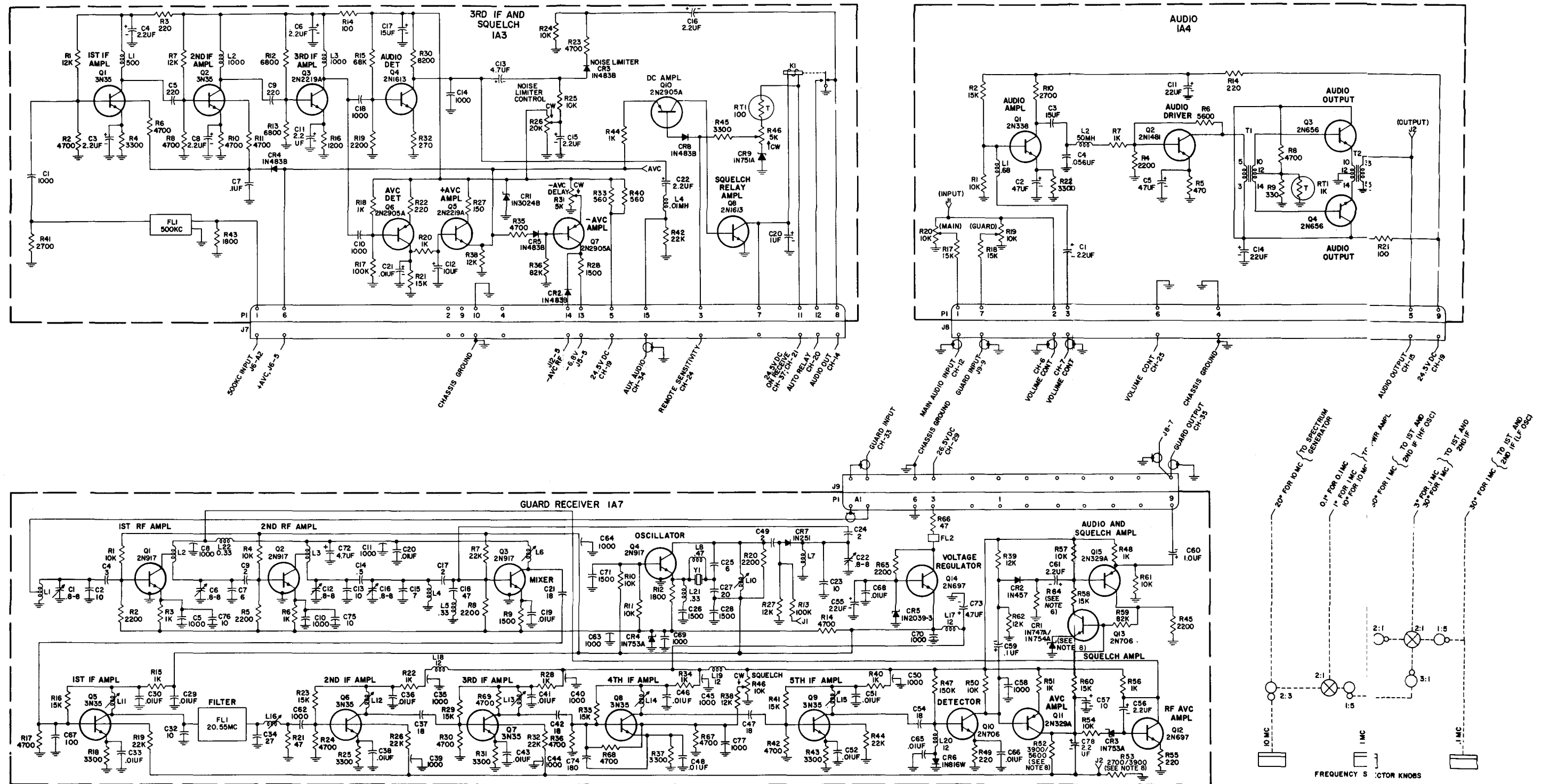

Figure 5-98. Radio Set AN/PRC-41A, Schematic Diagram (sheet 2 of 3)

Figure 5-98

NAVSHIPS 0967-872-5020  
TM-03816B-35/2  
TM 11-5820-510-35-1

AN/PRC-41A  
MAINTENANCE

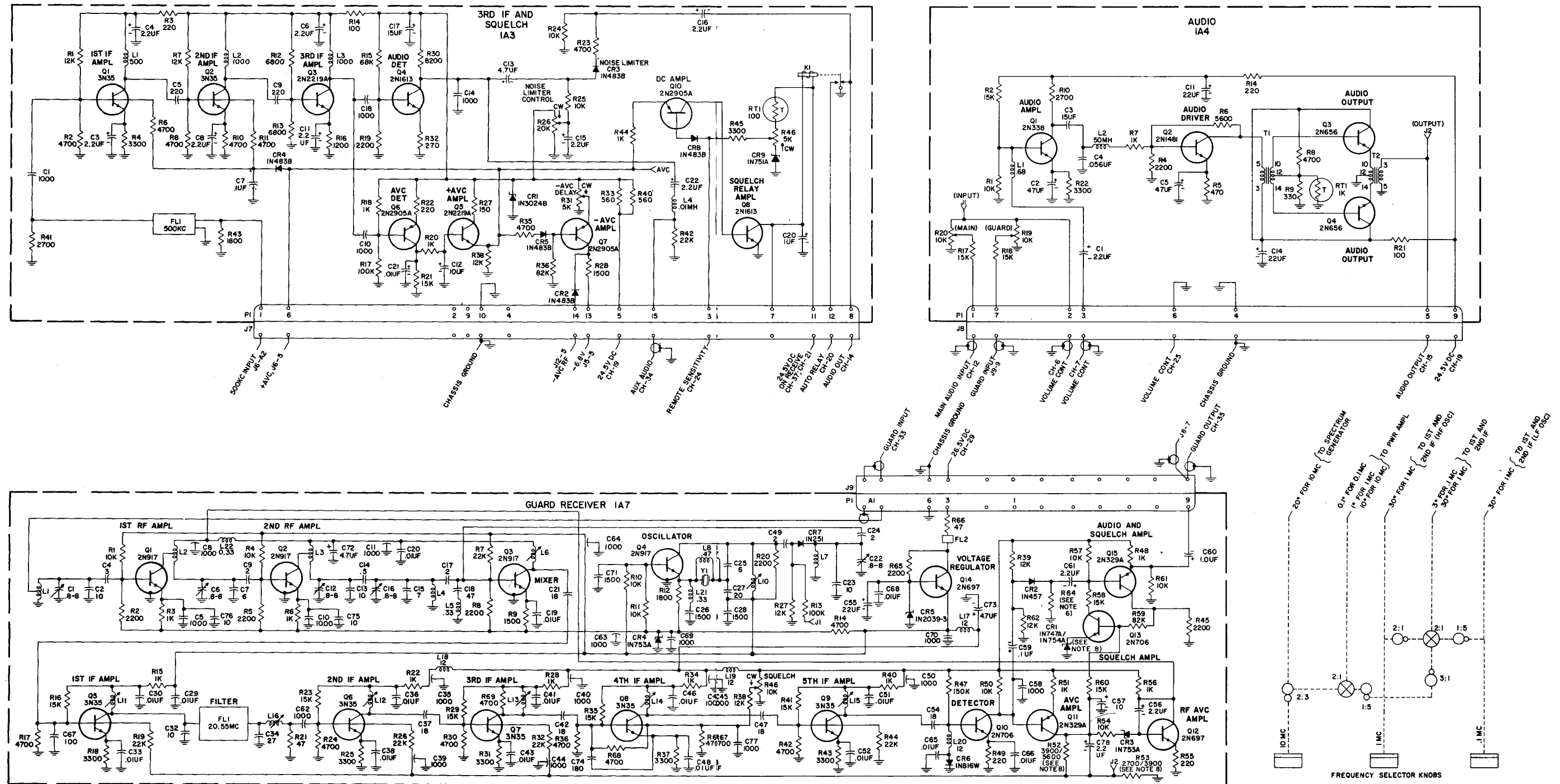

Figure 5-98. Radio Set AN/PRC-41A, Schematic Diagram (sheet 2 of 3)

ORIGINAL



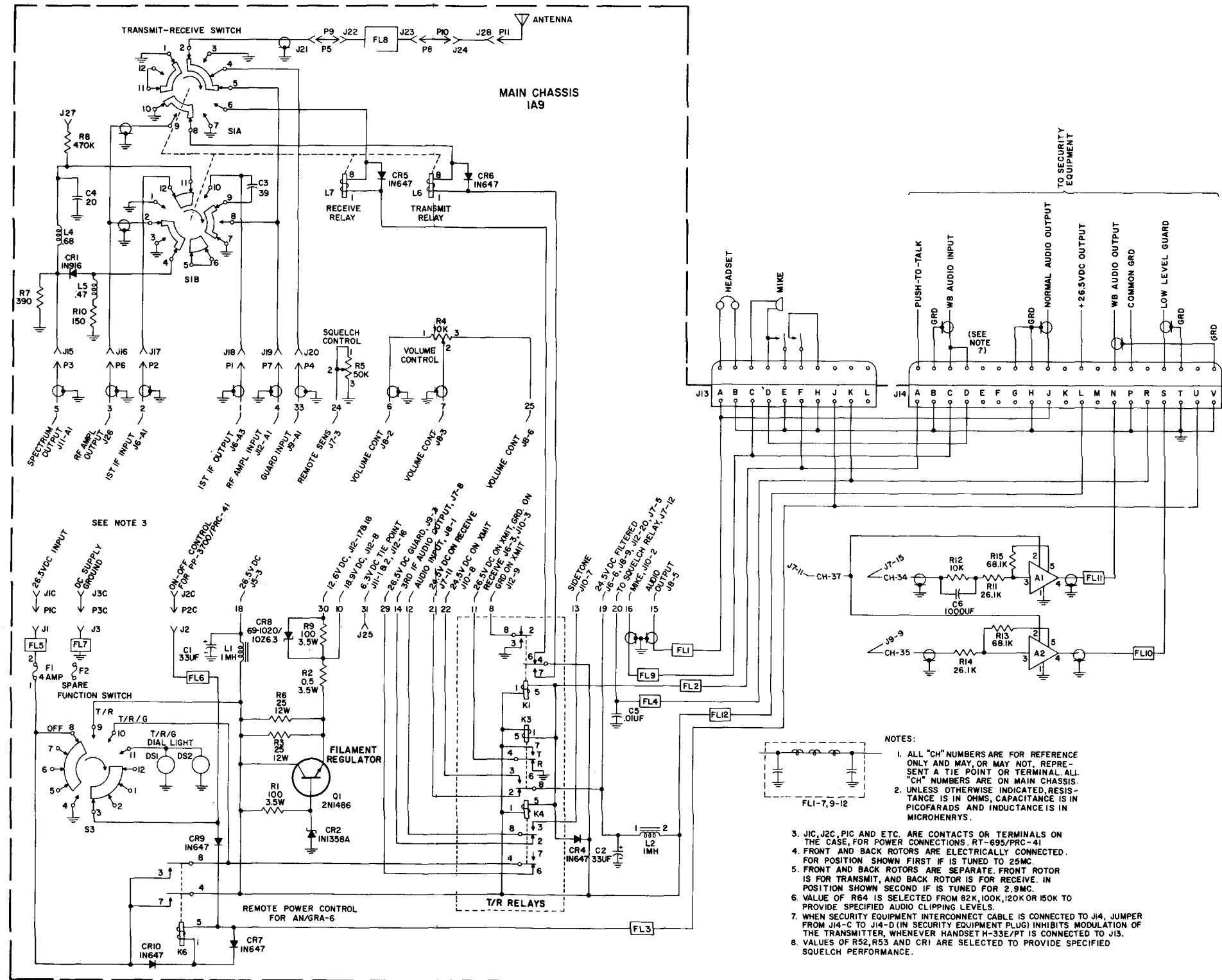

Figure 5-98. Radio Set AN/PRC-41A, Schematic Diagram (sheet 3 of 3)

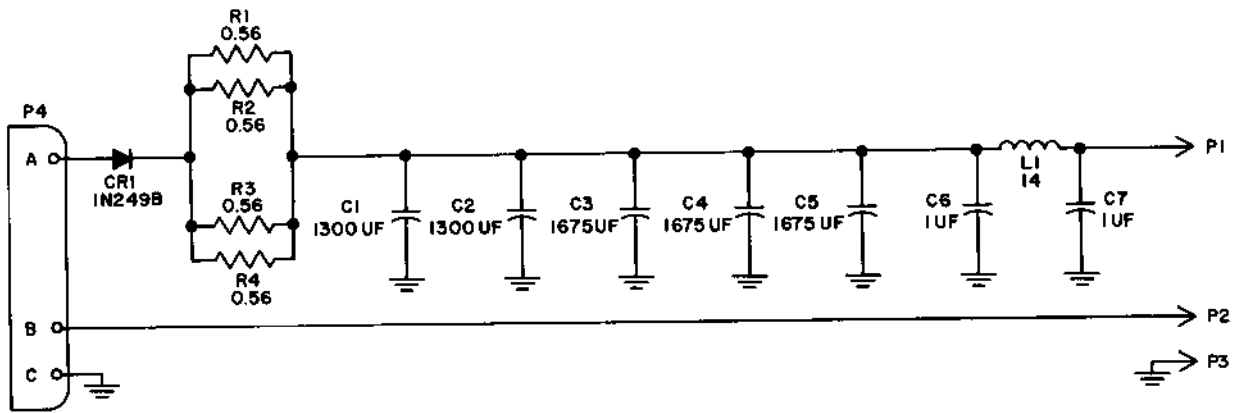
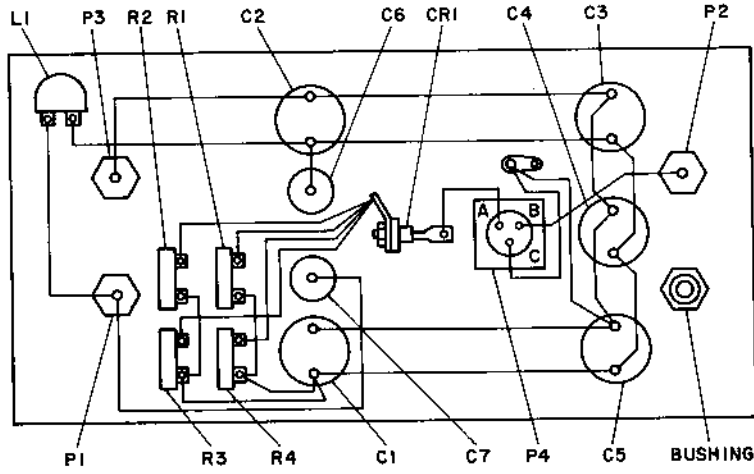

Figure 5-99. Mounting MT-2976/PRC-41, Wiring Diagram and Schematic Diagram



### **6-3. MAINTENANCE PARTS LIST .**

Table 6-2 lists all units and their maintenance parts. The units are listed in numerical sequence. Maintenance parts for each unit are listed alphabetically-numerically by class of part following the unit designation. Thus the parts for each unit are grouped together. Table 6-2 provides the following information: (1) the complete reference designation of each unit, assembly, subassembly, or part, (2) reference to explanatory notes in paragraph 6-6, (3) noun name and brief description, and (4) identification of the illustration which pictorially located the part.

Printed circuit boards, assembly boards, modules, etc. are listed first as individual items in the maintenance parts list. In addition, at the completion of a parts listing for each unit, the individual circuit board, assembly board, module, etc. is then broken down by components into separate parts listing. When there is a redundancy of such electronic assemblies in subsequent units, reference is made to the parts breakdown previously listed.

#### **Note**

Classified parts are designated by the following classification symbols placed in the NOTES column (in addition to any numerically identified notes) of the Maintenance Parts List: C, Confidential; CMH, Confidential- Modified Handling; S, Secret; TS, Top Secret. A brief description is given for all key parts (parts differing from any parts previously listed in this table) and sub-key parts (parts identical to a key part but appearing for the first time for a unit) . The names and descriptions are omitted for other parts, but reference is made to the key or sub-key part for the data. Unless otherwise indicated, all drawing numbers apply to equipment manufacturer and all type numbers apply to part manufacturer.

### **6-4. LIST OF MANUFACTURERS .**

Table 6-3 lists the manufacturers of parts used in the equipment. The table includes the manufacturer's code used in table 6-2 to identify the manufacturers.

### **6-5. STOCK NUMBER IDENTIFICATION .**

Allowance parts list (APL) issued by the Electronics Supply Office (ESO) include federal stock numbers and source maintenance and recoverability codes. Therefore, reference should be made to the APL prepared for the equipment for stock numbering information.

### **6-6. NOTES.**

The following notes provide information as referenced in table 6-2.

#### **1. GOVERNMENT FURNISHED EQUIPMENT.**

**TABLE 6-1. LIST OF UNITS**

UNIT NO	QTY	NAME OF UNIT	DESIGNATION	COLLOQUIAL NAME	PAGE
1	1	Radio Receiver-Transmitter	RT-695A/PRC-41	Receiver-Transmitter	6-3
2	3	Storage Battery	BB-451/U	Dc Power Supply	6-38
3	1	Power Supply	PP-3700/PRC-41	AC Power Supply	6-39
4	1	Antenna	AS-1405/PRC-41	Dirt, Antenna	6-42
5	1	Antenna	AS-1404/PRC-41	Omni, Antenna	6-43
6	1	Mounting	MT-2976/PRC-41	Mounting, Rec, & Xmtr	6-43
7	1	Battery Adapter		Battery Adapter	6-45
8	1	Power, Electric Cable Assembly	CX-8687/PRC-41	Cable Assembly	6-45
9	1	Power, Electric Cable Assembly	CX-8686/PRC-41	Cable Assembly	6-45
10	1	Radio Frequency Cable Assembly	CG-55G/U	Cable Assembly	6-45
11	1	Special Purpose Electrical Cable Assembly	CX-8688/PRC-41	Cable Assembly	6-45
12	1	Mast	AB-777/PRC-41	Ant. Mast	6-46
13	1	Antenna Mast Adapter		Ant. Mast Adapter	6-46
14	1	Mounting	MT-2977/PRC-41	Mount, Ac Power Supply	6-47
15	1	Handset	H-33E/PT	Handset	6-47
16	1	Electrical Equipment Harness		Harness	6-47
17	1	Bracket Assembly		Bracket Assembly	6-47

**TABLE 6-1. (Continued)**

UNIT NO	QTY	NAME OF UNIT	DESIGNATION	COLLOQUIAL NAME	PAGE
18	1	Spare Parts Kit		Spare Parts Kit	6-48
19	1	Maintenance Kit		Maintenance Kit	6-48
20	1	Tool Kit		Tool Kit	6-49
21	3	Guy Rope Assembly		Guy Rope Assembly	6-49
22	3	Guy Stake		Guy Stake	6-49
23	1	Directional Antenna Case		Dirt. Ant. Case	6-49
24	1	Radio Set Case	CY-3883/PRC-41	Radio Set Case	6-50
25	1	Electronic Equipment Case	CY-3885/PRC-41	Accessory Kit Case	6-50
26	1	Equipment Repair Parts		Equipment Repair Parts	6-50
27	1	Special Purpose Electrical Cable Assembly	CX-10831/PRC-41A	Cable Assembly	6-50

**TABLE 6-2. MAINTENANCE PARTS LIST**

RADIO RECEIVER-TRANSMITTER RT-695A/PRC-41

REF DESIG	NOTES	NAME AND DESCRIPTION	FIG NO
1		RADIO RECEIVER-TRANSMITTER: 225.0 to 399.99 Mhz freq range, 1 band, 1750 channels; 26.5 Vdc; 4-5/8 in by 11-3/8 in by 13-3/4 in o/a; mfr 13499 part no 787-6067-001	5-37

DC POWER SUPPLY MODULE

1A1		POWER SUPPLY: electronic type rectification full wave; 190 Vdc at 150 MA, 26.5 Vdc,-6.8 Vdc at 7mS; 1.437 in by 4 in by 4.375 in; mfr 13499 part no 528-0084-015	5-38
1A1C1		CAPACITOR, FXD, PPR, DIEL: 1 UF, ± 20%, 400V; mfr 56285 part no 18s4864	5-38

ORIGINAL

**TABLE 6-2. (Continued)**

DC POWER SUPPLY MODULE

REF NOTES	NOTES	NAME AND DESCRIPTION	FIG NO
1A1C2		CAPACITOR, FXD, PPR DIEL: same as 1A1C1	5-38
1A1C3		CAPACITOR, FXD, PPR DIEL: 3UF, ±20%, 400V; mfr 56289 part no 18S4865	5-38
1A1C4		CAPACITOR, FXD, ELCTLT: 15UF, ±20%, 20V, mfr 56289 part no 150D156X0020B2	5-39
1A1CR1		SEMICONV DEVICE: MIL-E-11/1143 type 1N649	5-39
1A1CR2		SEMICONV DEVICE: same as 1A1CR1	5-39
1A1CR3		SEMICONV DEVICE: same as 1A1CR1	5-39
1A1CR4		SEMICONV DEVICE: same as 1A1CR1	5-39
1A1CR5		SEMICONV DEVICE: mfr 07688 part no 1N1591A	5-39
1A1E1		TERMINAL: mfr 91663 part no RTMT12M	5-39
1A1E2		TERMINAL: same as 1A1E1	5-39
thru			
1A1E12			
1A1E13		CAP, XSTR: al, 11/16-24 intl thd, 3/4 in dia, 7/16 in dia, 7/16 in lg, mfr 13499 part no 548-7003-002	5-39
1A1E14		BASE, XSTR: al; 11/16-24 ext thd, 0.265 in lg, 0.391 in lg o/a, mfr 13499 part no 548-7002-002	5-39
1A1H1		SCREW EXTERNALLY RELIEVED BODY: alloy stl, zinc pl; hex skt cap screw, 8-32 NC-2 thd, 3/8 in lg., mfr 13499 part no 544-8109-002	5-38
1A1H2		NUT, PL,, RD,CAP: al, chromate dip, 0.21875 in w., 0 625in dia, mfr 13499 part no 548-7024-002	5-39
1A1H3		WASHER: glass cloth, silicone rbr, 0.086 in ID, 0 750 in OD, 0.050 in thk; mfr 13499 part no 547-7024-002	5-39
1A1J1		JACK: mfr 8291 part no SKT10WHITE	5-38
1A1J2		JACK: same as 1A1J1	5-38
1A1J3		JACK: same as 1A1J1	5-38
1A1L1		REACTOR: mfr 70674 part no A12008	5-38
1A1MP1		INSULATOR, BSHG: plstc; 5/16 in dia by 0.150 in lg, 0.177 in ID undercut to 0 096 in mfr 13499 part no 548-7004-002	5-38
1A1MP2		CHASSIS, ELEC EQPT: al alloy, chromate dip finish, 1 624 in by 1.914 in by 4 413 in mfr 13499 part no 548-7030-004	5-38
1A1P1		CONNECTOR: mfr 71468 part no DE9PC7	5-39
1A1Q1		TRANSISTOR: MIL-S-19500/180 (SIGC) type no 2N1486	5-39
1A1Q2		TRANSISTOR: same as 1A1Q1	5-39
1A1R1		RESISTOR, FXD, CMPSN: MIL-R-11 type RC20GF390K	5-39
1A1R2		RESISTOR, FXD, VW 1.2K ±5% 2.5 W. mfr 91637 part no RSM2C12000J	5-39
1A1R3		RESISTOR, FXD, WW: same as 1A1R2	5-39
1A1R4		RESISTOR, FXD, CMPSN: . same as 1A1R1	5-39
1A1R5		RESISTOR, FXD, CMPSN: MIL-R-11 type RC20GF474K	5-39
1A1T1		TRANSFORMER, PWR, STEP-DOWN AND STEP-UP 3 pri and 1 sec winding, 26 Vdc at 800 cps supply, 6 8V, 180V, 1-1/8 in by 1-5/16 in by 2-3/8 in, mfr 13499 part no 548-7028-003	5-38

ORIGINAL

**TABLE 6-2. (Continued)**

1ST AND 2ND IF AMPLIFIER MODULE

REF DESIG	NOTES	NAME AND DESCRIPTION	FIG NO
1A2		AMPLIFIER, INTMD FREQ: mfr 13499 part no 528-0085-03	5-37
1A2C1		CAPACITOR, FXD, CER DIELECTRIC: 10PF $\pm$ 1/4PF, 500V, mfr 72982 part no 331026C0H0100C	5-75
1A2C2		CAPACITOR, VAR, GLASS DIELECTRIC: : tubular, piston type, 0.8PF to 8.5PF, 1000V, mfr 73899 part no VC20GY	5-40
1A2C3		CAPACITOR, FXD, CER DIELECTRIC: 0.75PF $\pm$ 5%, 500V, mfr 78488 part no GA-75UUF PORM5PCT	5-40
1A2C4		CAPACITOR, FXD, CER DIELECTRIC: MIL type CC22CH100D	5-40
1A2C5		CAPACITOR, VAR GLASS DIELECTRIC: same as 1A2C2	5-40
1A2C6		CAPACITOR, FXD CER DIELECTRIC: MIL type CK14AX103M	5-40
1A2C7		CAPACITOR, FXD, CER DIELECTRIC: same as 1A2C6	5-40
1A2C8		CAPACITOR, VAR, GLASS DIELECTRIC: same as 1A2C2	5-40
1A2C9		CAPACITOR, FXD, CER DIELECTRIC: MIL type CC22CH070D	5-40
1A2C10		CAPACITOR, FXD, CER DIELECTRIC: same as 1A2C3	5-40
1A2C11		NOT USED	
1A2C12		CAPACITOR, VAR, GLASS DIELECTRIC: same as 1A2C2	5-40
1A2C13		CAPACITOR, FXD, CER DIELECTRIC: same as 1A2C6	5-40
1A2C14		CAPACITOR, FXD, CER DIELECTRIC: same as 1A2C6	5-40
1A2C15		CAPACITOR, VAR, GLASS DIELECTRIC: same as 1A2C2	5-40
1A2C16		CAPACITOR, FXD, CER DIELECTRIC: same as 1A2C9	5-40
1A2C17		CAPACITOR, FXD, CER DIELECTRIC: same as 1A2C3	5-40
1A2C18		CAPACITOR, FXD, CER DIELECTRIC: MIL type CC22CJ030C	5-40
1A2C19		CAPACITOR, FXD, CER DIELECTRIC: same as 1A2C6	5-40
1A2C20		CAPACITOR, VAR, GLASS DIELECTRIC: same as 1A2C2	5-40
1A2C21		CAPACITOR, FXD, CER DIELECTRIC: same as 1A2C14	5-40
1A2C22		CAPACITOR, FXD, CER DIELECTRIC: 47PF $\pm$ 5% 500V, mfr 72982 part no 338026C0H0470J	5-75
1A2C23		CAPACITOR, FXD, CER DIELECTRIC: same as 1A2C6	5-40
1A2C24		CAPACITOR, FXD, MICA DIELECTRIC: MIL type CM05F151G03	5-40
1A2C25		CAPACITOR, FXD, CER DIELECTRIC: 5.6PF $\pm$ 5%, 50V, mfr 78488	5-40
1A2C26		part no GA5-6UUF PORM5PCT CAPACITOR, FXD, MICA DIELECTRIC MIL type CM05F181G03	5-40
1A2C27		CAPACITOR, FXD, CER DIELECTRIC: same as 1A2C25	5-40
1A2C28		CAPACITOR, FXD, MICA DIELECTRIC: MIL type CM05F221G03	5-40
1A2C29		CAPACITOR, FXD, MICA DIELECTRIC: MIL type CM06F102G03	5-40



9 1A2C3	CAPACITOR, FXD, CER DIEI: same as 1A2C6	5-78
0 1A2C3	CAPACITOR, FXD, CER DIEI: 22PF $\pm$ 5%, 500V; mfr 72982	5-75
1 1A2C3	part no 331026C0H0220J CAPACITOR, FXD, CER DIEI: 100PF $\pm$ 2% 500V mfr 72982	5-75
2 1A2C3	part no 338026U2J0101G CAPACITOR, VAR, GLASS DIEI: 0.8PF to 8 5PF, 750V, mfr 72899	5-75
3 1A2C3	part no VC9GWY CAPACITOR, FXD, CER DIEI: same as 1A2C32	5-75
4 1A2C3	CAPACITOR, FXD, CER DIEI: same as 1A2C6	5-76
5 1A2C3	CAPACITOR, FXD, CER DIEI: MIL type CK12AX102M	5-86
6 1A2C3	CAPACITOR, FXD, CER DIEI: same as 1A2C36	5-76
7 1A2C3	CAPACITOR, FXD, MICA DIEI: MIL type CM05F181J03	5-76
8 1A2C3	CAPACITOR, FXD, CER DIEI: 20PF $\pm$ 2%, 500V; mfr 72982	5-76
9 1A2C4	part no 331026U2J0200G CAPACITOR, FXD, CER DIEI: same as 1A2C25	5-40
0 1A2C4	CAPACITOR, FXD, CER DIEI: .same as 1A2C6	5-40
1		

ORIGINAL

**TABLE 6-2. (Continued)**

1ST AND 2ND IF AMPLIFIER MODULE

REF DESIG	NOT ES	NAME AND DESCRIPTION	FIG NO
1A2C42		CAPACITOR, FXD, CER DIEL same as 1A2C6	5-78
1A2C43		CAPACITOR, FXD, CER DIEL same as 1A2C32	5-78
1A2C44		CAPACITOR, FXD, CER DIEL: 43PF, $\pm 5\%$ , 500V; mfr 72982 part no 338026C0H0430J	5-78
1A2C45		CAPACITOR, FXD, CER DIEL same as 1A2C36	5-78
1A2C46		CAPACITOR, FXD, CER DIEL same as 1A2C32	5-78
1A2C47		CAPACITOR, FXD, ELCTLT MIL type CS13BF105M	5-78
1A2C48		NOT USED	
1A2C49		CAPACITOR, FXD, CER DIEL same as 1A2C36	5-78
1A2C50		CAPACITOR, FXD, CER DIEL same as 1A2C36	5-75
1A2C51		CAPACITOR, FXD, CER DIEL same as 1A2C32	5-75
1A2C52		CAPACITOR, FXD, CER DIEL same as 1A2C18	5-40
1A2C53		CAPACITOR, FXD, CER DIEL same as 1A2C25	5-40
1A2C54		CAPACITOR, FXD, CER DIEL same as 1A2C36	5-75
1A2C55		CAPACITOR, FXD, CER DIEL same as 1A2C36	5-78
1A2C56		CAPACITOR, FXD, CER DIEL same as 1A2C4	5-40
1A2C57		CAPACITOR, FXD, CER DIEL same as 1A2C6	5-40
1A2C58		NOT USED	
1A2C59		NOT USED	
1A2C60		NOT USED	
1A2C61		CAPACITOR, FXD, CER DIEL same as 1A2C36	5-40
1A2C62		CAPACITOR, FXD, CER DIEL same as 1A2C36	5-76
1A2C63		CAPACITOR, FXD, CER MEL same as 1A2C6	5-75
1A2C64		CAPACITOR, FXD, CER DIEL same as 1A2C39	5-75
1A2C65		CAPACITOR, FXD, CER DIEL same as 1A2C6	5-75
1A2C66		CAPACITOR, FXD, CER DIEL MIL type CC22LH270J	5-40
1A2C67		NOT USED	
thru			
1A2C74			
1A2C76		CAPACITOR, FXD, CER DIEL same as 1A2C9	5-40
1A2CR1		SEMICONV DEVICE: MIL-S-19500/188 type 1N251	5-78
1A2CR2		SEMICONV DEVICE. same as 1A2CR1	5-75
1A2CR3		SEMICONV DEVICE : same as 1A2CR1	5-40
1A2H1		WASHER, FLAT brs, cad, 0.099 IN ID, 0.187 in OD, 0.020 in thk; mfr 13499 part no 504-0705-003	5-76
1A2H2		SCREW SHOULDER, NO 1 CRES, passivate finish 0.127 in hex 0.270 in dia 3.546 in lg, mfr 13499 part no 544-8222-002	5-75
1A2H3		WASHER, FLAT brs, 0.188 in ID, 0.3125 in OD, 0.020 in thk, mfr 13499 part no 544-8632-002	5-75
1A2H4		NUT, PL, HEX brs, sil pl, 1/4 in hex; 8-32 UNC-2B thd, 1/16 in thk, mfr 13499 part no 544-8678-002	5-75
1A2H5		CAP, RIVET CRES, Passivate finish, 0.027 in ID, 0.218 in OD, 0.029 in thk, mfr 13499 part no 502-1512-002	5-78
1A2H6		WASHER, SPR TNSN: ph brz, 0.281 in ID, 0.370 in OD, 0.010 in thk, mfr 13499 part no 544-8634-002	5-40
1A2H7		NUT, SLUG ADJUSTING brs, bright alloy plate, 0.216 in ID, 0.281 in OD, 0.250 in w, mfr 13499 part no 540-8601-002	5-75
1A2J1		JACK, TIP mfr 98291 part no SKT2BC	5-75
1A2J2		JACK, TIP same as 1A2J1	5-78
1A2J3		JACK, TIP same as 1A2J1	5-75

ORIGINAL

**TABLE 6-2. (Continued)**

## 1ST AND 2ND IF AMPLIFIER MODULE

REF DESIG	NOTES	NAME AND DESCRIPTION	FIG NO
1A2K1		RELAY, AMT: mfr 01526 part no 3SAF1263	5-75
1A2K2		RELAY same as 1A2K1	5-75
1A2K3		RELAY contact arrangement 2BRF, 1V max rated voltage, 100UA resistive current rating, cont arrangement 1B, DC, 28V max rated voltage 1 amp resistive current rating, mfr 13499 part no 544-8688-002	5-75
1A2L1		COIL, RF 25 turns, single layer wound type, no 30 AWG enamel insulated wire, 0.072 ohms DC res, mfr 13499 part no 544-8671-002	5-40
1A2L2		COIL, RF same as 1A2L1	5-40
1A2L3		COIL, RF same as 1A2L1	5-40
1A2L4		COIL, RF same as 1A2L1	5-40
1A2L5		COIL, RF same as 1A2L1	5-40
1A2L6		COIL, RF same as 1A2L1	5-40
1A2L7		COIL, RF MIL-C-15305 type LT4K030	5-75
1A2L8		COIL, RF MIL-C-15305 type LT4K041	5-76
1A2L9		COIL, RF 23 turns, single layer wound type, no 32 AWG polyurethane insulated wire, 17.1 MHz, min self-resonant freq, 0.262 ohm DC res, mfr 13499 part no 544-8703-003	5-77
1A2L10		COIL, RF 22 turns, single layer wound type, no 32 AWG polyurethane insulated wire, 18.1 MHz, min self-resonant freq, 0.229 ohm DC res; mfr 13499 part no 544-8704-003	5-77
1A2L11		COIL, RF 21 turns, single layer wound type, no 32 AWG polyurethane insulated wire; 19.1 MHz, min self-resonant freq, 0.213 ohm DC res, mfr 13499 part no 544-8705-003	5-77
1A2L12		COIL, RF 19 turns, single layer wound type, no 32 AWG polyurethane insulated wire, 20.1 MHz, min self-resonant freq, 0.196 ohm DC res, mfr 13499 part no 544-8706-003	5-77
1A2L13		COIL, RF 18 turns, single layer wound type, no 32 AWG polyurethane insulated wire, 21.1 MHz, min self-resonant freq, 0.196 ohm DC res, mfr 13499 part no 544-8707-003	5-77
1A2L14		COIL, RF 17 turns, single layer wound type, no 32 AWG polyurethane insulated wire, 22.1 MHz, min self-resonant freq, 0.180 ohm DC res, mfr 13499 part no 544-8708-003	5-77
1A2L15		COIL, RF 16 turns, single layer wound type, no 32 AWG polyurethane insulated wire, 23.1 MHz, min self-resonant freq, 0.180 ohm DC res, mfr 13499 part no 544-8709-003	5-77
1A2L16		COIL, RF 15 turns, single layer wound type, no 32 AWG polyurethane insulated wire, 24.1 MHz, min self-resonant freq, 0.164 ohm DC res, mfr 13499 part no 544-8710-003	5-77
1A2L17		COIL, RF 14 turns, single layer wound type, no 32 AWG polyurethane insulated wire, 25.1 MHz, min self-resonant freq; 0.164 ohm DC res; mfr 13499 part no 544-8711-003	5-77
1A2L18		COIL, RF 13 turns, single layer wound type, no 32 AWG polyurethane insulated wire, 26.1 MHz, min self-resonant freq, 0.147 ohm DC res, mfr 13499 part no 544-8712-003	5-77
1A2L19		COIL, RF 53 turns, single layer wound type; no 32 AWG enamel insulated wire; 0.182 ohm DC res, mfr 13499 part no 544-6872-002	5-40
1A2L20		COIL, RF same as 1A2L12	5-40
1A2L21		COIL, RF same as 1A2L19	5-40
1A2L22		COIL, RF same as 1A2L12	5-40

ORIGINAL

TABLE 6-2. (Continued)

## 1ST AND 2ND IF AMPLIFIER MODULE

REF DESIG	NOTES	NAME AND DESCRIPTION	FIG NO
1A2L23		COIL, RFsame as 1A2L19	5-40
1A2L24		COIL, RFsame as 1A2L12	5-40
1A2L25		COIL, RF: MIL-C-15305 type LT4K038	5-75
1A2L26		BEAD: mfr 02114 part no 56-590-65-3B	5-75
1A2L27		BEAD: same as 1A2L26	5-75
1A2L28		BEAD: same as 1A2L26	5-75
1A2L29		BEAD: same as 1A2L26	5-75
1A2L30		COIL, RF: 0.47UH, mfr 82142 part no 4412-1M75	5-75
1A2L31 thru 1A2L49		NOT USED	
1A2L50		COIL, RF: 27UH; mfr 99800 part no 1537-48	5-40
1A2MP1		BEARING mfr 83086 part no SFR155PPK25-7	5-75
1A2MP2		NOT USED	
1A2MP3		NUT, PLAIN, HEX: al chemical finish, 4-40 UNC-2B tied, 0.343 in lg, mfr 13499 part no 540-9036-003	5-78
1A2MP4		NUT, PLAIN, HEX al, chemical finish, 4-40 UNC-2B thd, 0.312 in lg; mfr 13499 part no 540-9035-003	5-78
1A2MP5		SPACER, SLV al, 0.035 in thk by 0.187 in OD by 0.187 in lg; mfr 13499 part no 541-5977-002	5-78
1A2MP6		SPRING HELICAL, EXTENSION CRES: 0.187 in by 0.411 in in o/a dim; mfr 13499 part no 544-8633-002	5-75
1A2MP7		NUT, PL, HEX al, chemical finish, 4-40 UNC-2B thd, 0.218 in lg, mfr 13499 part no 540-9032-003	5-78
1A2MP8		CAM, CONTROL brs, 0.187 in by 0.796 in by 0.828 in o/a dim; mfr 13499 part no 544-8629-002	5-75
1A2MP9		CAM, CONTROL: brs, 0.187 in by 0.796 in by 0.796 in o/a dim; mfr 13499 part no 544-8630-002	5-75
1A2MP10		COUPLING, SHAFT, FLEX. Insert type, 0.906 in by 0.250 in o/a dim, mfr 13499 part no 546-4872-002	5-75
1A2MP11		SHAFT, STR: CRES, Passivate finish, 0.1873 in dia, 3.454 in lg; mfr 13499 part no 546-4875-002	5-75
1A2MP12		CAM, CONTROL- brs, 0.187 in by 0.625 in by 0.796 in o/a dim; mfr 13499 part no 544-8636-002	5-75
1A2MP13		CAM, CONTROL- brs; 0.187 in by 0.593 in by 0.781 in o/a dim, mfr 13499 part no 544-8637-002	5-75
1A2MP14		SHAFT, STR: CRES, Passivate finish, 0.1873 in dia, 3.454 in lg, mfr 13499 part no 546-4876-002	5-75
1A2MP15		SHAFT, STR: CRES, Passivate finish, 0.1873 in dia, 3.454 in lg, mfr 13499 part no 546-4877-002	5-75
1A2MP16		COVER, AMPL al; 0.032 in by 3.234 in by 4.421 in o/a dim; mfr 13499 part no 544-8669-002	5-75
1A2MP17		COVER, AMPL al; 0.032 in by 3.234 in by 4.421 in o/a dim, mfr 13499 part no 544-8670-002	5-75
1A2MP18		BEARING mfr 83086 part no SR144PK28-7	5-75
1A2MP19		RING mfr 79136 part no 5100-12C	5-75
1A2MP20		CLIP, RETAINING: CRES, 0.030 in by 0.199 in by 0.310 in o/a dim; mfr 13499 part no 502-6005-002	5-75
1A2MP21		POST, FOLLOWER: CRES, PASSIVATE finish, 0.1245 in ala, 1.850 in lg, mfr13499 part no 544-8638-002	5-75

TABLE 6-2. (Continued)

## 1ST AND 2ND IF AMPLIFIER MODULE

REF DESIG	NOTES	NAME AND DESCRIPTION	FIG NO
1A2MP22		BASE, AMPL: CRES; incl 3 nuts; 1 in by 1.522 in by 2.218 in o/a dim; mfr 13499 part no 544-8676-002	5-75
12AMP23		RING: mfr 79136 part no 5133-12C	5-75
1A2MP24		POST, FOLLOWER: CRES, passivate finish, 0.1245 in dia, 2.890 in lg; mfr 13499 part no 544-8635-002	5-75
1A2MP25		BASE, AMPL CRES, incl 6 nuts; 1.344 in by 2.156 in by 2.562 in o/a dim, mfr 13499 part no 544-8677-002	5-75
1A2MP26		CORE mfr 92054 part no 52-3811	5-75
1A2MP27		SCREW, ADJUSTABLE CORE brs sil pl 0.025 in ID, 0.089 in OD, 0.438 in lg, mfr 13499 part no 544-8673-002	5-75
1A2MP28		INSULATOR, DISK. silicone rbr; 25/64 in dia by 1/16 in thk, mfr 13499 part no 546-6075-002	5-75
1A2MP29		NOT USED	
1A2MP30		NUT, SLV: al, chemical, 4-40 UNC-2B thd; 0.562 in lg; mfr 13499 part no 540-9043-003	5-76
1A2MP31		PLATE, COIL MOUNTING: al, chromate dip, 0.032 in by 1.343 in mfr 13499 part no 544-8641-002	5-77
1A2MP32		NUT, SLV al, chemical; 4-40 UNC-2B trd, 0.500 in lg; mfr 13499 part no 540-9041-003	5-77
1A2MP33		NUT, PL, HEX: al, chromate dip, 4-40 UNC-2B tied, 0.187 in w across flats, 0.687 in lg o/a, mfr 13499 part no 540-9047-003	5-77
1A2MP34		RING mfr 79136 part no 5100-27C	5-40
1A2MP35		COVER, AMPL: bra, sil pl; 0.032 in thk. 1.453 in dia, 2.352 in lg, mfr 13499 part no 544-8644-002	5-40
1A2MP36		SPACER, SLV al, chromate dip, 0.093 in by 0.156 in by 0.562 in mfr 13499 part no 545-7138-002	5-76
1A2MP37		PLATE, XTAL HOLDER: al, chromate dip, 0.032 in thk, 1.3125 in by 1.328 in mfr 13499 part no 544-8651-002	5-76
1A2MP38		BRACKET, CONN, RCPT, ELEC: al, chromate dip, 0.250 in by 0.344 in by 0.531 in; mfr 13499 part no 544-8657-002	5-78
1A2MP39		AMPLIFIER SUBASSEMBLY: 3.370 in by 4.253 in by 4.432 in o/a dim, mfr 13499 part no 546-4885-003	5-75
1A2MP40		DAMPENER, XTAL, NO 2 rbr sheet; 1-1/4 in by 1-1/4 in mfr 13499 part no 544-8682-002	5-76
1A2MP41		SHIELD, RF brs, sil pl finish, 0.0320 in by 1.933 in by 2.281 in mfr 13499 part no 554-7063-004	5-75
1A2MP42		PLATE, ELEC SHIELD: sil pl cop cont stripe, sil pl brs plate; 0.125 in by 1.764 in by 3.094 in mfr 13499 part no 554-6937-002	5-75
1A2MP43		POST, ELEC-MECH EQPT CRES, PASSIVATE finish; 0.086 in by 0.187 in by 0.750 in mfr 13499 part no 554-6935-002	5-75
1A2P1		CONNECTOR: mfr 71468 part no DBM13W3PC27; includes 3 plugs CONNECTOR: mfr 71468 part no DM 53740-5000 (p/o 1A2P1) qty 3	5-75
1A2Q1		TRANSISTOR: MIL-S-19500/80A(SIGC) type 3N35	5-40
1A2Q2		TRANSISTOR: mfr 07688 part no 2N915	5-40
1A2Q3		TRANSISTOR same as 1A2Q1	5-75
1A2Q4		TRANSISTOR same as 1A2Q1	5-75
1A2Q5		TRANSISTOR: same as 1A2Q1	5-75
1A2Q6		TRANSISTOR: MIL-T-19500/69B(NAVY) type 2N338	5-78
1A2Q7		TRANSISTOR same as 1A2Q6	5-78

ORIGINAL

TABLE 6-2. (Continued)

. 1ST AND 2ND IF AMPLIFIER MODULE

REF DESIG	NOTES	NAME AND DESCRIPTION	FIG NO
1A2R1		RESISTOR, FXD, CMPSN: MIL-R-11 type RC07GF153K	5-40
1A2R2		RESISTOR, FXD, CMPSN: MIL-R-11 type RC07GF272K	5-40
1A2R3		RESISTOR, FXD, CMPSN: same as 1A2R2	5-40
1A2R4		RESISTOR, FXD, CMPSN: MIL-R-11 type RC07GF273K	5-40
1A2R5		RESISTOR, FXD, CMPSN: MIL-R-11 type RC07GF102K	5-40
1A2R6		RESISTOR, FXD, CMPSN: MIL-R-11 type RC07GF471K	5-40
1A2R7		RESISTOR, FXD, CMPSN: same as 1A2R5	5-40
1A2R8		RESISTOR, FXD, CMPSN: MIL-R-11 type RC07GF221K	5-40
1A2R9		RESISTOR, FXD, CMPSN: MIL-R-11 type RC07GF104K	5-75
1A2R10		RESISTOR, FXD, CMPSN: MIL-R-11 type RC07GF682K	5-40
1A2R11		RESISTOR, FXD, CMPSN: same as 1A2R1	5-75
1A2R12		RESISTOR, FXD, CMPSN: MIL-R-11 type RC07GF472K	5-75
1A2R13		RESISTOR, FXD, CMPSN: same as 1A2R12	5-75
1A2R14		RESISTOR, FXD, CMPSN: MIL-R-11 type RC07GF103K	5-75
1A2R15		RESISTOR, FXD, CMPSN: same as 1A2R5	5-40
1A2R16		RESISTOR, FXD, CMPSN: MIL-R-11 type RC07GF152K	5-78
1A2R17		RESISTOR, FXD, CMPSN: MIL-R-11 type RC07GF333K	5-78
1A2R18		RESISTOR, FXD, CMPSN: same as 1A2R5	5-78
1A2R19		RESISTOR, FXD, CMPSN: same as 1A2R12	5-78
1A2R20		RESISTOR, FXD, CMPSN: same as 1A2R1	5-75
1A2R21		RESISTOR, FXD, CMPSN: same as 1A2R12	5-75
1A2R22		RESISTOR, FXD, CMPSN: MIL-R-11 type RC07GF182K	5-75
1A2R23		RESISTOR, FXD, CMPSN: same as 1A2R14	5-75
1A2R24		RESISTOR, FXD, CMPSN: same as 1A2R1	5-76
1A2R25		RESISTOR, FXD, CMPSN: same as 1A2R12	5-76
1A2R26		RESISTOR, FXD, CMPSN: same as 1A2R22	5-76
1A2R27		RESISTOR, FXD, CMPSN: same as 1A2R14	5-76
1A2R28		RESISTOR, FXD, CMPSN: MIL-R-11 type RC20GF120K	5-75
1A2R29		RESISTOR, FXD, CMPSN: same as 1A2R5	5-76
1A2R30		RESISTOR, FXD, CMPSN: same as 1A2R5	5-78
1A2R31		RESISTOR, FXD, CMPSN: MIL-R-11 type RC07GF393K	5-78
1A2R32		RESISTOR, FXD, CMPSN: same as 1A2R2	5-78
1A2R33		RESISTOR, FXD, CMPSN: MIL-R-11 type RC07GF332K	5-78
1A2R34		RESISTOR, FXD, CMPSN: same as 1A2R9	5-78
1A2R35		RESISTOR, FXD, CMPSN: MIL-R-11 type RC07GF101K	5-40
1A2R36		RESISTOR, FXD, CMPSN: same as 1A2R14	5-40
1A2R37		RESISTOR, FXD, CMPSN: same as 1A2R12	5-78
1A2R38		RESISTOR, FXD, CMPSN: same as 1A2R5	5-75
1A2R39		RESISTOR, FXD, CMPSN: same as 1A2R9	5-40
1A2R40		RESISTOR, FXD, CMPSN: MIL-R-11 type RC07GF121K	5-75
1A2S1		PRINTED CIRCUIT PLATE: plstc board; 0.062 in by 1.325 in by 1.343 in board dim; mfr 13499 part no 544-8695-003	5-77
1A2S2		PRINTED CIRCUIT PLATE same as 1A2S1	5-76
1A2S3		PRINTED CIRCUIT PLATE plstc board, 0.062 in by 1.297 in by 3.343 in o/a dim, mfr 13499 part no 544-8697-003	5-78
1A2Y1		CRYSTAL UNIT, QTZ: 2.90000 MHz, mfr 00136 part no 290-9303-00	5-78
1A2Y2		CRYSTAL UNIT, QTZ: 3.00000 MHz, mfr 00136 part no 290-9604-00	5-78
1A2Y3		CRYSTAL UNIT, QTZ: 3.10000 MHz, mfr 00136 part no 290-9605-00	5-78
1A2Y4		CRYSTAL UNIT, QTZ: 3.20000 MHz, mfr 00136 part no 290-9606-00	5-78
1A2Y5		CRYSTAL UNIT, QTZ: 3.30000 MHz, mfr 00136 part no 290-9607-00	5-78

**TABLE 6-2. (Continued)**

## 1ST AND 2ND IF AMPLIFIER MODULE

REF DESIG	NOTES	NAME AND DESCRIPTION	FIG NO
1A2Y6		CRYSTAL UNIT, QTZ :3.40000 MHz, mfr 00136 part no 290-9608-00	5-78
1A2Y7		CRYSTAL UNIT, QTZ: 3.50000 MHz, mfr 00136 part no 290-9609-00	5-78
1A2Y8		CRYSTAL UNIT, QTZ: 3.60000 MHz; mfr 00136 part no 290-9610-00	5-78
1A2Y9		CRYSTAL UNIT, QTZ: 3.70000 MHz; mfr 00136 part no 290-9611-00	5-78
1A2Y10		CRYSTAL UNIT, QTZ. 3.80000 MHz, mfr 00136 part no 290-9612-00	5-78
1A2Y11		CRYSTAL UNIT, QTZ: 17.10000 MHz; mfr 94217 part no M04496	5-76
1A2Y12		CRYSTAL UNIT, QTZ: 18.10000 MHz, mfr 94217 part no M04495	5-76
1A2Y13		CRYSTAL UNIT, QTZ: 19.10000 MHz; mfr 94217 part no M04494	5-76
1A2Y14		CRYSTAL UNIT, QTZ: 20.10000 MHz, mfr 94217 part no M04493	5-76
1A2Y15		CRYSTAL UNIT, QTZ: 21.10000 MHz; mfr 94217 part no M04492	5-76
1A2Y16		CRYSTAL UNIT, QTZ: 22.10000 MHz, mfr 94217 part no M04491	5-76
1A2Y17		CRYSTAL UNIT, QTZ: 23.10000 MHz, mfr 94217 part no M04490	5-76
1A2Y18		CRYSTAL UNIT, QTZ: 24.10000 MHz, mfr 94217 part no M04489	5-76
1A2Y19		CRYSTAL UNIT, QTZ: 25.10000 MHz, mfr 94217 part no M04488	5-76
1A2Y20		CRYSTAL UNIT, QTZ: 26.10000 MHz, mfr 94217 part no M04487	5-76

## 3RD IF AND SQUELCH MODULE

REF DESIG	NOTES	NAME AND DESCRIPTION	FIG NO
1A3		AMPLIFIER, INTMD FREQ 500 Hz operating freq, 47 Hz band w at 6 db down, 50 ohms input 10,000 ohms output, 26.5Vdc operating pwr, 0.397 in by 3.250 in by 4.437 in; mfr 13499 part no 528-0372-017	5-37
1A3C1		CAPACITOR, FXD, CER DIE L MIL type CK12AX102M	5-42
1A3C2		NOT USED	
1A3C2		CAPACITOR, FXD, ELCTLT MIL type CS13BE225M	5-42
1A3C4		CAPACITOR, FXD, ELCTLT same as 1A3C3	5-42
1A3C5		CAPACITOR, FXD, MICA DIE L MIL type CM05FD221J03	5-42
1A3C6		CAPACITOR, FXD, ELCTLT- same as 1A3C3	5-42
1A3C7		CAPACITOR, FXD, ELCTLT MIL type CS13BH104M	5-42
1A3C8		CAPACITOR, FXD, ELCTLT same as 1A3C3	5-42
1A3C9		CAPACITOR, FXD, MICA DIE L same as 1A3C5	5-42
1A3C10		CAPACITOR, FXD, CER DIE L. same as 1A3C1	5-42
1A3C11		CAPACITOR, FXD, CER DIE L same as 1A3C3	5-42
1A3C12		CAPACITOR, FXD, ELCTLT MIL type CS13BE106M	5-42
1A3C13		CAPACITOR, FXD, ELCTLT MIL type CS13BF475M	5-41
1A3C14		CAPACITOR, FXD, CER DIE L: same as 1A3C1	5-41
1A3C15		CAPACITOR, FXD, ELCTLT same as 1A3C3	5-41
1A3C16		CAPACITOR, FXD, ELCTLT same as 1A3C3	5-41
1A3C17		CAPACITOR, FXD, ELCTLT MIL type CS13BE156M	5-41
1A3C18		CAPACITOR, FXD, CER DIE L same as 1A3C1	5-41
1A3C19		NOT USED	
1A3C20		CAPACITOR, FXD, ELCTLT: MIL type CS13BF105M	5-41
1A2C21		CAPACITOR, FXD, CER DIE L MIL type CK14AX103M	5-42
1A2C22		CAPACITOR, FXD, ELCTLT same as 1A3C3	5-41
1A3CR1		SEMICOND DEVICE: JAN type 1N3024B	5-41
1A3CR2		SEMICOND DEVICE: JAN type JAN1N483B	5-41
1A2CR3		SEMICOND DEVICE same as 1A3CR2	5-41
1A3CR4		SEMICOND DEVICE: same as 1A3CR2	5-42
1A3CR5		SEMICOND DEVICE. same as 1A3CR2	5-41

**TABLE 6-2. (Continued)**

3RD IF AND SQUELCH MODULE

REF DESIG	NOTES	NAME AND DESCRIPTION	FIG NO
1A3CR 6		NOT USED	
1A3CR 7		NOT USED	
1A3CR 8		SEMICOND DEVICE: same as 1A3CR2	5-41
1A3CR 9		SEMICOND DEVICE: JAN type JAN1N751A	5-41
1A3E1		PRINTED CIRCUIT BOARD: plstc; 0.062 in by 3.070 in by 3.437 in; mfr 13499 part no 767-1971-001	5-42
1A3E2		PRINTED CIRCUIT BOARD: plstc; 0.062 in by 3.070 in by 3.162 in; mfr 13499 part no 767-1958-001	5-41
1A3FL1		FILTER: mfr 81815 part no TL80D110C1	5-42
1A3J1		JACK, TIP: WHT; mfr 98291 part no SKT41WHT	5-41
1A3K1		RELAY: mfr 01526 part no 3SAK1029	5-41
1A3L1		COIL, RF: MS type MS90539-08	5-42
1A3L2		COIL, RF: MS type MS90539-15	5-42
1A3L3		COIL, RF: same as 1A3L2	5-42
1A3L4		COIL, RF: MS type MS90541-11	5-41
1A3MP1		COVER, CHASSIS: al; 0.032 in by 3.218 in by 4.406 in; mfr 13499 part no 548-7371-003	5-41
1A3MP2		COVER, CHASSIS: al; 0.032 in by 3.218 in by 4 406 in mfr 13499 part no 548-7370-003	5-42
1A3MP3		SCREW, SHOULDER, NO 2 CRES, passivate finish; 8-32 UNC-2A thd, 0 127 in hex, 0.270 in dia, 3.584 in lg, mfr 13499 part no 544-8223-002	5-41
1A3P1		CONNECTOR: mfr 71468 part no DAM15PA160C37	5-41
1A3Q1		TRANSISTOR: JAN type 3N35	5-42
1A3Q2		TRANSISTOR: same as 1A3Q1	5-42
1A3Q3		TRANSISTOR: JAN type JAN2N2219A	5-42
1A3Q4		TRANSISTOR: JAN type JAN2N1613	5-41
1A3Q5		TRANSISTOR: same as 1A3Q3	5-42
1A3Q6		TRANSISTOR: JAN type JAN2N2905A	5-42
1A3Q7		TRANSISTOR: same as 1A3Q6	5-41
1A3Q8		TRANSISTOR: same as 1A3Q4	5-41
1A3Q9		NOT USED	
1A3Q10		TRANSISTOR: same as 1A3Q6	5-41
1A3R1		RESISTOR, FXD, CMPSN: MIL type RC07GF123K	5-42
1A3R2		RESISTOR, FXD, CMPSN: MIL type RC07GF472K	5-42
1A3R3		RESISTOR, FXD, CMPSN: MIL type RC07GF221K	5-42
1A3R4		RESISTOR, FXD, CMPSN: MIL type RC07GF272K	5-42
1A3R5		NOT USED	
1A3R6		RESISTOR, FXD, CMPSN: same as 1A3R2	5-42
1A3R7		RESISTOR, FXD, CMPSN: same as 1A3R1	5-42
1A3R8		RESISTOR, FXD, CMPSN: same as 1A3R2	5-42
1A3R9		NOT USED	
1A3R10		RESISTOR, FXD, CMPSN: same as 1A3R4	5-42
1A3R11		RESISTOR, FXD, CMPSN: same as 1A3R2	5-42
1A3R12		RESISTOR, FXD, CMPSN: MIL type RC07GF682K	5-42
1A3R13		RESISTOR, FXD, CMPSN: same as 1A3R12	5-42
1A3R14		RESISTOR, FXD, CMPSN: MIL type RC07GF101K	5-42
1A3R15		RESISTOR, FXD, CMPSN: MIL type RC07GF683K	5-41
1A3R16		RESISTOR, FXD, CMPSN: MIL type RC07GF182K	5-42



**TABLE 6-2. (Continued)**

3RD IF AND SQUELCH MODULE

REF DESIG	NOTES	NAME AND DESCRIPTION	FIG NO
1A3R17		RESISTOR, FXD, CMPSN: MIL type RC07GF104K	5-42
1A3R18		RESISTOR, FXD, CMPSN: MIL type RC07GF102K	5-42
1A3R19		RESISTOR, FXD, CMPSN: MIL type RC07GF222K	5-41
1A3R20		RESISTOR, FXD, CMPSN: same as 1A3R18	5-42
1A3R21		RESISTOR, FXD, CMPSN: MIL type RC07GF153K	5-42
1A3R22		RESISTOR, FXD, CMPSN: same as 1A3R3	5-42
1A3R23		RESISTOR, FXD, CMPSN: same as 1A3R2	5-41
1A3R24		RESISTOR, FXD, CMPSN: MIL type RC07GF103K	5-41
1A3R25		RESISTOR, FXD, CMPSN: same as 1A3R24	5-41
1A3R26		RESISTOR, VAR, WW: MIL type RT12C2L203	5-42
1A3R27		RESISTOR, FXD, CMPSN: MIL type RC07GF151K	5-42
1A3R28		RESISTOR, FXD, CMPSN: MIL type RC20GF152K	5-41
1A3R29		NOT USED	
1A3R30		RESISTOR, FXD, CMPSN: MIL type RC07GF822K	5-41
1A3R31		RESISTOR, VAR, WW: MIL type RT12C2L502	5-41
1A3R32		RESISTOR, FXD, CMPSN: MIL type RC07GF271K	5-41
1A3R33		RESISTOR, FXD, CMPSN: MIL type RC20GF561K	5-41
1A3R34		NOT USED	
1A3R35		RESISTOR, FXD, CMPSN: same as 1A3R2	5-41
1A3R36		RESISTOR, FXD, CMPSN: MIL type RC07GF823K	5-41
1A3R37		NOT USED	
1A3R38		RESISTOR, FXD, CMPSN: same as 1A3R1	5-42
1A3R39		NOT USED	
1A3R40		RESISTOR, FXD, CMPSN: same as 1A3R33	5-41
1A3R41		RESISTOR, FXD, CMPSN: same as 1A3R4	5-42
1A3R42		RESISTOR, FXD, CMPSN: MIL type RC07GF223K	5-41
1A3R43		RESISTOR, FXD, CMPSN: same as 1A3R16	5-42
1A3R44		RESISTOR, FXD, CMPSN: same as 1A3R18	5-41
1A3R45		RESISTOR, FXD, CMPSN: MIL type RC07GF332K	5-41
1A3R46		RESISTOR, VAR, WW same as 1A3R31	5-41
1A3RT1		RESISTOR, THRM: 100 ohms, 10%; mfr 10646 part no 997F18	5-41

AUDIO AMPLIFIER

1A4		AMPLIFIER, AF: 0.5 W pwr output; mfr 13499 part no 528-0087-015	5-37
1A4C1		CAPACITOR, FXD, ELCTLT: 2.2UF, ±20%, 35V; mfr 56289 part no 150D225X0035B2	5-43
1A4C2		CAPACITOR, FXD, ELCTLT: 47UF, ±20%, 20V; mfr 56289 part no 150D476X0020R2	5-43
1A4C3		CAPACITOR, FXD, ELCTLT: 15UF, ±20%, 20V, mfr 56289 part no 150D156X0020B2	5-43
1A4C4		CAPACITOR, FXD, ELCTLT: 0.056UF, ±10%, 35V; mfr 56289 part no 150D563X9035A2	5-43
1A4C5		CAPACITOR, FXD, ELCTLT: same as 1A4C2	5-43
1A4C6 thru 1A4C10		NOT USED	

ORIGINAL

TABLE 6-2. (Continued)

## AUDIO AMPLIFIER

REF DESIG	NOTES	NAME AND DESCRIPTION	FIG NO
1A4C11		CAPACITOR, FXD, ELCTLT: 22UF, $\pm 20\%$ , 35V; mfr 56289 part no 150D226X0035R2	5-43
1A4C12		NOT USED	
1A4C13		NOT USED	
1A4C14		CAPACITOR, FXD, ELCTLT: same as 1A4C11	5-43
1A4H1		SCREW, SHOULDER, NO 1 CRES, passivate finish; 8-32 UNC-2A thd, 0.127 in hex, 0.270 in dia, 3.546 in lg; mfr 13499 part no 544-8222-002	5-43
1A4J1		JACK, TIP: WHT; mfr 98291 part no SKT41WHITE	5-43
1A4J2		JACK, TIP: same as 1A4J1	5-43
1A4L1		COIL, RF: MS type MS16225-5	5-43
1A4L2		COIL, RF: 50MH; mfr 13499 part no MP206-14B	5-43
1A4MP1		COVER, AMPL: al, chromate dip finish, 0.032 in by 3.209 in by 3.437 in; mfr 13499 part no 548-7001-002	5-43
1A4MP2		PLATE ASSEMBLY, CHASSIS: al plate; 0.032 in by 2.616 m by 3.250 in, incl 33 terminals and 4 transistor holders; mfr 13499 part no 548-7022-004	5-43
1A4P1		CONNECTOR: dielectric; straight shape; 0.421 in by 0.484 in by 1.203 in; mfr 71468 part no DE9PC7	5-43
1A4Q1		TRANSISTOR: MIL-T-19500/69B (NAVY) type 2N338	5-43
1A4Q2		TRANSISTOR: MIL-T-19500/207 (SIGC) type 2N1481	5-43
1A4Q3		TRANSISTOR: MIL-T-19500/74 (NAVY) type 2N656	5-43
1A4Q4		TRANSISTOR: same as 1A4Q3	5-43
1A4R1		RESISTOR, FXD, CMPSN: MIL-R-11 type RC07GF103K	5-43
1A4R2		RESISTOR, FXD, CMPSN: MIL-R-11 type RC07GF153K	5-43
1A4R3		NOT USED	
1A4R4		RESISTOR, FXD, CMPSN: MIL-R-11 type RC07GF222K	5-43
1A4R5		RESISTOR, FXD, CMPSN: MIL-R-11 type RC07GF471K	5-43
1A4R6		RESISTOR, FXD, CMPSN: MIL-R-11 type RC07GF562K	5-43
1A4R7		RESISTOR, FXD, CMPSN: MIL-R-11 type RC07GF102K	5-43
1A4R8		RESISTOR, FXD, CMPSN: MIL-R-11 type RC07GF472K	5-43
1A4R9		RESISTOR, FXD, CMPSN: MIL-R-11 type RC07GF331K	5-43
1A4R10		RESISTOR, FXD, CMPSN: MIL-R-11 type RC07GF272K	5-43
1A4R11		NOT USED	
1A4R12		NOT USED	
1A4R13		NOT USED	
1A4R14		RESISTOR, FXD, CMPSN: MIL-R-11 type RC07GF221K	5-43
1A4R15		NOT USED	
1A4R16		NOT USED	
1A4R17		RESISTOR, FXD, CMPSN: same as 1A4R2	5-43
1A4R18		RESISTOR, FXD, CMPSN: same as 1A4R2	5-43
1A4R19		RESISTOR, VAR, WW 10K, $\pm 5\%$ , 1W; mfr 80294 part no 224L1-103	5-43
1A4R20		RESISTOR, VAR, WW: same as 1A4R19	5-43
1A4R21		RESISTOR, FXD, CMPSN: MIL-R-11 type RC20GF101K	5-43
1A4R22		RESISTOR, FXD, CMPSN: MIL-R-11 type RC07GF332K	5-43
1A4RT1		RESISTOR, THRM 1K at 25 deg C; 1.8K at 25 deg C, designed for ac, dc; mfr 10646 part no 997F17	5-43
1A4T1		TRANSFORMER mfr 70674 part no A11874	5-43
1A4T2		TRANSFORMER mfr 70674 part no A11873	5-43

**TABLE 6-2. (Continued)**

SPECTRUM GENERATOR MODULE

REF DESIG	NOTES	NAME AND DESCRIPTION	FIG NO
1A5		SPECTRUM GENERATOR: mfr 13499 part no 528-0373-007	5-37
1A5C1		CAPACITOR, FXD, CER DIELECTRIC: 1000PF, GMV, 500V, mfr 72982 part no 2465009W5T0102P	5-79
1A5C2		CAPACITOR, FXD, CER DIELECTRIC: same as 1A5C1	5-79
1A5C3		CAPACITOR, FXD, CER DIELECTRIC: MIL-C-20D type CC22CH060C	5-79
1A5C4		CAPACITOR, FXD, CER DIELECTRIC: 1000PF, M20%P100%, 500V mfr 71590 part no BB61-102TW6X	5-79
1A5C5		CAPACITOR, FXD, MICA DIELECTRIC: MIL-C-20D type CC20CH040C	5-79
1A5C6		CAPACITOR, FXD, MICA DIELECTRIC: 470PF, ±5%, 500V; mfr 72136 part no DM15F471500WV4CR	5-79
1A5C7		CAPACITOR, FXD, CER DIELECTRIC: same as 1A5C4	5-79
1A5C8		NOT USED	
1A5C9		CAPACITOR, FXD, MICA DIELECTRIC: MIL type CM05E200J03	5-79
1A5C10		CAPACITOR, VAR, GLASS DIELECTRIC 0.8PF to 4.5PF; mfr 73899 part no VC21GY	5-79
1A5C11		CAPACITOR, FXD, CER DIELECTRIC: 2.0PF to 1/4PF, 500V, mfr 72982 part no 331026C0K0209C	5-79
1A5C12		CAPACITOR, FXD, CER DIELECTRIC: same as 1A5C1	5-79
1A5C13		CAPACITOR, FXD, CER DIELECTRIC: 20PF, ±5%, 500V, mfr 72982 part no 331026 C0H0200J	5-79
1A5C14		CAPACITOR, FXD, CER DIELECTRIC: same as 1A5C1	5-79
1A5C15		CAPACITOR, VAR, GLASS DIELECTRIC: same as 1A5C10	5-79
1A5C16		CAPACITOR, FXD, CER DIELECTRIC: same as 1A5C11	5-79
1A5C17		CAPACITOR, FXD, CER DIELECTRIC: same as 1A5C1	5-79
1A5C18		CAPACITOR, FXD, CER DIELECTRIC 400PF, M0%P100%, 360V, mfr 72982 part no 2404032W5P0401P	5-79
1A5C19		CAPACITOR, FXD, CER DIELECTRIC: same as 1A5C13	5-79
1A5C20		CAPACITOR, VAR, GLASS DIELECTRIC: same as 1A5C10	5-79
1A5C21		CAPACITOR, FXD, CER DIELECTRIC: 1.5PF to 1/4PF, 500V, mfr 72982 part no 331026C0K0159C	5-79
1A5C22		CAPACITOR, FXD, MICA DIELECTRIC: MIL type CM05E510J03	5-79
1A5C23		CAPACITOR, FXD, CER DIELECTRIC: same as 1A5C1	5-79
1A5C24		NOT USED	
1A5C25		CAPACITOR, FXD, CER DIELECTRIC: same as 1A5C18	5-79
1A5C26		CAPACITOR, FXD, CER DIELECTRIC: same as 1A5C18	5-79
1A5C27		CAPACITOR, FXD, CER DIELECTRIC: same as 1A5C1	5-79
1A5C28		CAPACITOR, FXD, CER DIELECTRIC: same as 1A5C1	5-79
1A5C29		CAPACITOR, FXD, CER DIELECTRIC: same as 1A5C18	5-79
1A5C30		CAPACITOR, FXD, CER DIELECTRIC: 470PF, 20%, 500V, mfr 56289 part no 40C204A5	5-79
1A5C31		NOT USED	
1A5C32		NOT USED	
1A5C33		CAPACITOR, FXD, CER DIELECTRIC: same as 1A5C1	5-79
1A5C34		NOT USED	
1A5C35		NOT USED	
1A5C36		CAPACITOR, FXD, CER DIELECTRIC: same as 1A5C18	5-79
thru			
1A5C41			
1A5C42		NOT USED	
1A5C43		NOT USED	

ORIGINAL

TABLE 6-2. (Continued)

## SPECTRUM GENERATOR MODULE

REF DESIG	NOTES	NAME AND DESCRIPTION	FIG NO
1A5C44		NOT USED	
1A5C45		CAPACITOR, FXD, MICA DIELECTRIC: same as 1A5C6	5-79
1A5CR1		NOT USED	
1A5CR2		SEMICONDUCTOR DEVICE. MIL-S-19500/188 type 1N251	5-79
1A5E1		CONTACT, ELEC: beryllium cop, gold-plated finish; 0.234 in by 0.499 in by 1.531 in o/a dim; mfr 13499 part no 539-5340-003	5-79
1A5E2		CONNECTOR: mfr 71468 part no DM53740-5000	5-79
1A5E3		CONTACT, ELEC beryllium cop, gold-plated contact surface, 0.484 in dia by 0.040 in h o/a dim, mfr 13499 part no 544-7455-003	5-79
1A5E4		CONTACT, ELEC cop, gold plated; 1-1/16 dia by 1/4 in h; mfr 13499 part no 544-8407-002	5-79
1A5E5		ROTOR, ELEC SWITCH: mfr 13499 part no 549-3809-002	5-79
1A5E6		PRINTED CIRCUIT BOARD: plstc, cop clad, 2.312 in dia by 0.031 in thk o/a dim; mfr 13499 part no 549-3787-003	5-79
1A5E7		CONTACT, ELEC beryllium cop, goldplated finish, 0.562 in by 0.687 in by 0.687 in mfr 13499 part no 548-7893-003	5-79
1A5E8		CONTACT ASSEMBLY, ELEC: mfr 13499 part no 549-3808-002	5-79
1A5E9		STATOR, SOLDERED: 0.687 in by 1.125 in by 1.750 in o/a dim, mfr 13499 part no 544-8481-002	5-79
1A5E10		ROTOR, SOLDERED: 1.125 in dia by 0.562 in o/a dim, mfr 13499 part no 544-8482-002	5-79
1A5E11		CONTACT, ELEC: beryllium cop, gold plated finish; 0.531 in dia by 0.050 in h o/a dim, mfr 13499 part no 547-0797-003	5-79
1A5E12		NOT USED	
1A5E13		COIL ASSEMBLY, RF: 18 RF coils mounted on printed circuit board; mfr 13499 part no 549-3810-003	5-79
1A5E14		NOT USED	
1A5E15		NOT USED	
1A5E16		PRINTED CIRCUIT BOARD: plstc, cop clad; 0.031 in by 2.109 in by 2.289 in o/a dim, mfr 13499 part no 549-3779-004	5-79
1A5H1		WASHER, FINISH cop, alloy-plated finish; 0.091 in ID countersunk 82 deg. 0.212 in OD, 0.062 in thk, mfr 13499 part no 545-6590-002	5-79
1A5H2		SCREW, EXTERNALLY RELIEVED BODY alloy stl, zinc-plated; hex skt cap screw 8-32 NC-2 thd, 3/8 in lg; mfr 13499 part no 544-8109-002	5-79
1A5H3		NUT, PL, HEX CRES, passivate finish; 0.563 in hex, 0.062 in thk, mfr 13499 part no 544-8410-002	5-79
1A5H4		WASHER, RECESSED: al, chromate dip, 0.187 in ID, 0.438 in OD, 0.050 in thk, mfr 13499 part no 544-8444-002	5-79
1A5H5		NUT, SLV CRES, passivate finish; 0.375 in hex; 0.187 in lg, 0.2499 in dia, mfr 13499 part no 544-8446-002	5-79
1A5J1		JACK, TIP BRN, mfr 98291 part no SKT-41BROWN	5-79
1A5J2		JACK, TIP same as 1A5J1 p/o 1A5MP24	5-79
1A5L1		COIL, RF 9 turns; single layer wound, no 26 AWG, polyurethane insulation, 40 ohms DC res; color coded red and orn; mfr 13499 part no 549-3839-004	5-79
1A5L2		COIL, RF: 9 turns, single layer wound, no 26 AWG, polyurethane insulation, 40 ohms DC res; color coded red, mfr 13499 part no 549-3838-004	5-79

ORIGINAL

**TABLE 6-2. (Continued)**

## SPECTRUM GENERATOR MODULE

REF DESIG	NOTES	NAME AND DESCRIPTION	FIG NO
1A5L3		COIL, RF: 8 turns; single layer wound, no 26 AWG; polyurethane insulation; 40 ohms DC res, color coded brn and wht; mfr 13499 part no 549-3837-004	5-79
1A5L4		COIL, RF: 8 turns, single layer wound, no 26 AWG, polyurethane insulation; 40 ohms DC res, color coded brn and vio, mfr 13499 part no 549-3836-004	5-79
1A5L5		COIL, RF: 7 turns, single layer wound, no 26 AWG; polyurethane insulation; 40 ohms DC res; color coded brn and blu, mfr 13499 part no 549-3835-004	5-79
1A5L6		COIL, RF: 7 turns, single layer wound, no 26 AWG, polyurethane insulation, 40 ohms DC res, color coded brn and grn, mfr 13499 part no 549-3834-004	5-79
1A5L7		COIL, RF: 7 turns; single layer wound; no 26 AWG, polyurethane insulation, 40 ohms DC res, color coded brn and yel, mfr 13499 part no 549-3833-004	5-79
1A5L8		COIL, RF: 6 turns; single layer wound, no 26 AWG, polyurethane insulation, 40 ohms DC res; color coded brn and orn, mfr 13499 part no 549-3832-004	5-79
1A5L9		COIL, RF: 9 turns, single layer wound; no 26 AWG; polyurethane insulation, 40 ohms DC res, color coded brn and red, mfr 13499 part no 549-3831-004	5-79
1A5L10		COIL, RF: 8 turns, single layer wound, type, no 26 AWG, polyurethane insulation, 40 ohms DC res, color coded brn, mfr 13499 part no 549-3830-004	5-79
1A5L11		COIL, RF :8 turns single layer wound, no 26 AWG; polyurethane insulation, 40 ohms DC res, color coded wht, mfr 13499 part no 549-3829-004	5-79
1A5L12		COIL, RF: 7 turns single layer wound type, no 26 AWG, polyurethane insulation, 40 ohms DC res; color coded vio; mfr 13499 part no 549-3828-004	5-79
1A5L13		COIL, RF: 7 turns single layer wound, no 26 AWG, polyurethane insulation, 40 ohms DC res, color coded blu, mfr 13499 part no 549-3827-004	5-79
1A5L14		COIL, RF: 7 turns; single layer wound, no 26 AWG, polyurethane insulation; 40 ohms DC res, color coded grn, mfr 13499 part no 549-3826-004	5-79
1A5L15		COIL, RF: 6 turns; single layer wound, no 26 AWG; polyurethane insulation;; 40 ohms DC res, color coded yel, mfr 13499 part no 549-3825-004	5-79
1A5L16		COIL, RF 6 turns, single layer wound, no 26 AWG, polyurethane insulation; 40 ohms DC res, color coded orn, mfr 13499 part no 549-3824-004	5-79
1A5L17		COIL, RF: 6 turns, single layer wound, no 26 AWG, polyurethane insulation, 40 ohms DC res; color coded red; mfr 13499 part no 549-3823-004	5-79
1A5L18		COIL, RF: 6 turns, single layer wound, no 26 AWG, polyurethane insulation, 40 ohms DC res, color coded brn; mfr 13499 part no 549-3822-004	5-79
1A5L19		COIL, RF: MS type MS18130-5	5-79
1A5L20		NOT USED	

ORIGINAL

**TABLE 6-2. (Continued)**

SPECTRUM GENERATOR MODULE

REF DESIG	NOTE S	NAME AND DESCRIPTION	FIG NO
1A5L21		COIL, RF: MIL-C-15305 type LT4K030	5-79
1A5L22		COIL, RF: same as 1A5L21	5-79
thru			
1A5L25		NOT USED	
1A5L26		CHOKE, BIFILAR: 0.125 in dia by 0.484 in lg o/a dim, mfr 13499	5-79
1A5L27		part no 546-9210-002	
		CHOKE, BIFILAR: same as 1A5L27	5-79
1A5L28		NOT USED	
1A5L29		NOT USED	
1A5L30		COIL, RF: same as 1A5L21	5-79
1A5L31		NOT USED	
1A5L32		COIL, RF: same as 1A5L21	5-79
1A5L33		COIL, RF: same as 1A5L21	5-79
1A5L34		NOT USED	
1A5L35		NOT USED	
1A5L36		COIL, RF: same as 1A5L21	5-79
1A5L37		NOT USED	
thru			
1A5L41		BEAD: mfr 02114 part no 56-590-65-3B	5-79
1A5L42		BEAD: same as 1A5L42	5-79
1A5L43			
thru			
1A5L61		NOT USED	
1A5L62		NOT USED	
thru			
1A5L65		COIL, RF: MS type MS16225-7	5-79
1A5L66		NOT USED	
1A5L67		NOT USED	
1A5L68		NOT USED	
1A5L69		COIL, RF: MIL-C-15305 type LT4K027	5-79
1A6I70		COIL, RF: same as 1A5I69	5-79
1A5L71		BEAD: same as 1A5L42	5-79
thru			
1A5L74		RING: mfr 78189 part no 213-141216-00-2303	5-79
1A5MP1		BEARING: mfr 83086 part no SR156PPK28-7	5-79
1A5MP2		BEARING: mfr 83086 part no SFR156PPK28-7	5-79
1A5MP3		RING: MS type MS16633-1018	5-79
1A5MP4		RING: MS type MS16632-1018	5-79
1A5MP5		COUPLING HAL, SHAFT: sst, passivate finish, 0.3125 in OD,	5-79
1A5MP6		0.106 in thk flange, 0.289 in lg o/a, 0.420 in lg of bore, mfr 13499	
		part no 540-8152-002	
1A5MP7		COLLAR, SHAFT: al chromate dipped; 0.228 in ID, 0.375 in OD,	5-79
		0.137 in w, mfr 13499 part no 544-7442-002	
1A5MP8		POST, ELEC-MECH EQPT: al, chromate dipped, hex cross	5-79
		sectional shape, 0.750 in lg of post, 0.187 in w across flats; 2-56	
		intl thd size; mfr 13499 part no 540-9018-003	
1A5MP9		INSERT, FLEX COUPLING: plstc, 0.938 in dia by 0.185 in lg,	5-79
		mfr 13499 part no 548-7038-002	

ORIGINAL

TABLE 6-2. (Continued)

## SPECTRUM GENERATOR MODULE

REF DESIG	NOTES	NAME AND DESCRIPTION	FIG NO
1A5MP10		HOUSING, BEARING: CRES, passivate finish; 0.234 in ID to counterboard 0.3132 in ID, 7/16-32 thd, 0.234 in lg; mfr 13499 part no 544-8408-002	5-79
1A5MP11		COLLAR, SHAFT, NO 2: brs, 0.228 in ID, 0.375 in OD, 0.164 in w, mfr 13499 part no 544-8409-002	5-79
1A5MP12		POST, CHASSIS, NO 1: brs, sil pl, 0.186 in by 0.186 in by 2.938 in, mfr 13499 part no 549-3788-003	5-79
1A5MP13		GEAR, SPUR-CRES; 0.531 in OD by 0.265 in lg o/a dim, mfr 13499 part no 544-8419-002	5-79
1A5MP14		GEAR, SPUR: ph brz, 0.781 in dia by 0.156 in lg o/a dim, mfr 13499 part no 544-8445-002	5-79
1A5MP15		INSULATOR, PLATE: plstc, 5/8 in by 1-1/16 in, mfr 13499 part no 547-0785-002	5-79
1A5MP16		COVER, GENERATOR SET: al; 0.032 in by 2.359 in by 2.921 in o/a dim, mfr 13499 part no 544-8470-002	5-79
1A5MP17		COVER, GENERATOR: al; 0.125 in by 3.109 in by 3.625 in o/a dim, mfr 13499 part no 549-3791-003	5-79
1A5MP18		COVER, GENERATOR SET: al, 0.375 in by 3.109 in by 3.625 in o/a dim; mfr 13499 part no 548-7752-003	5-79
1A5MP19		COVER, GENERATOR: al, chromate dip, 0.422 in by 2.329 in by 3.156 in; mfr 13499 part no 548-7751-003	5-79
1A5MP20		COVER, GENERATOR: al, 0.040 in by 2.359 in by 2.437 in o/a dim, mfr 13499 part no 549-3802-003, c/o 1A5J1	5-79
1A5MP21		PLATE, MOUNTING, SPECTRUM: al, 0.489 in by 2.438 in by 4.437 in o/a dim; mfr 13499 part no 544-8514-004, c/o 1A5MP22,, 1A5MP23	5-79
1A5MP22		BEARING: mfr 70417 part no F347-4 MILL6085A, p/o 1A5MP21	5-79
1A5MP23		PIN, LOCATING: brs, chemical polish, 0.1249 in ID, 0.1867 in OD, 0.344 in lg, mfr 13499 part no 544-0277-002, p/o 1A5MP21	5-79
1A5MP24		PLATE, RETAINING, BEARING: al, 0.452 in by 1.871 in by 2.375 in o/a dim, mfr 13499 part no 548-7132-003, c/o 1A5J2	5-79
1A5MP25		SHAFT, STR, OSC: CRES, passivate finish; 0.1873 in dia, 2.093 in lg, mfr 13499 part no 549-3793-003	5-79
1A5MP26		COLLAR, PRINTED CIRCUIT BOARD: al, chromate dip; 7/16 in ID, 13/16 in OD, 9/32 in lg, mfr 13499 part no 549-3785-002	5-79
1A5MP27		INSULATOR, PLATE: plstc, 0.136 in ID, 0.250 in OD, 0.125 in thk, mfr 13499 part no 548-7682-002	5-79
1A5MP28		PLATE, CHASSIS: brs, 0.406 in by 2.491 in by 2.352 in o/a dim, mfr 13499 part no 548-7681-003	5-79
1A5MP29		GEARSHAFT, SPUR: brs, 0.968 in dia by 3.203 in lg o/a dim, mfr 13499 part no 544-8451-002	5-79
1A5MP30		CHASSIS, ELEC EQPT: mfr 13499 part no 549-3817-004	5-79
1A5MP31		PLATE, COVER: tees, sil pl, 3/4 in by 27/32 in; mfr 13499 547-0789-002	5-79
1A5MP32		PLATE, ELEC SHIELD: brs, 0.381 in by 2.359 in by 2.796 in o/a dim; mfr 13499 part no 548-7755-004	5-79
1A5MP33		GEAR, SPUR: ph brz, 1.031 in dia by 0.265 in lg o/a dim, mfr 13499 part no 544-8453-002	5-79
1A5P1		CONNECTOR: mfr 71468 part no DAM11W1PC27	5-79
1A5R1		RESISTOR, FXD, CMPSN: MIL-R-11 type RC42GF333K	5-79
1A5R2		RESISTOR, FXD, CMPSN: same as 1A5R1	5-79

ORIGINAL

**TABLE 6-2. (Continued)**

## SPECTRUM GENERATOR MODULE

REF DESIG	NOTE S	NAME AND DESCRIPTION	FIG NO
1A5R3		RESISTOR, FXD, CMPSN: MIL-R-11 type RC07GF104K	5-79
1A5R4		RESISTOR, FXD, CMPSN: MIL-R-11 type RC07GF103K	5-79
1A5R5		RESISTOR, FXD, CMPSN: MIL-R-11 type RC07GF681K	5-79
1A5R6		RESISTOR, FXD, CMPSN: MIL-R-11 type RC07GF153K	5-79
1A5R7		RESISTOR, FXD, CMPSN: MIL-R-11 type RC07GF331K	5-79
1A5R8		NOT USED	
1A5R9		NOT USED	
1A5R10		RESISTOR, FXD, CMPSN: same as 1A5R5	5-79
1A5R11		RESISTOR, FXD, CMPSN: MIL-R-11 type RC07GF223K	5-79
1A5R12		NOT USED	
1A5R13		RESISTOR, FXD, CMPSN: MIL-R-11 type RC07GF224K	5-79
1A5R14		RESISTOR, FXD, CMPSN: MIL-R-11 type RC07GF101K	5-79
1A5R15		RESISTOR, FXD, CMPSN: MIL-R-11 type RC07GF471K	5-79
1A5V1		ELECTRON TUBE: MIL-E-1 type 7077	5-79
1A5V2		ELECTRON TUBE: same as 1A5V1	5-79
1A5V3		ELECTRON TUBE: MIL-E-1 type 7554	5-79
1A5V4		ELECTRON TUBE: same as 1A5V3	5-79
1A5XV1		SOCKET: mfr 04435 part no 86-001	5-79
1A5XV2		SOCKET: same as 1A5XV1	5-79
1A5Y1		CRYSTAL UNIT, QTZ: 66.66667 MHz, mfr 00136 part no 289-1986-00	5-79
1A5Y2		CRYSTAL UNIT, QTZ: 70.0000 MHz; mfr 00136 part no 289-1987-00	5-79
1A5Y3		CRYSTAL UNIT, QTZ: 73.3333 MHz; mfr 00136 part no 289-1988-00	5-79
1A5Y4		CRYSTAL UNIT, QTZ: 76.6667 MHz; mfr 00136 part no 289-1989-00	5-79
1A5Y5		CRYSTAL UNIT, QTZ: 80.00000 MHz; mfr 00136 part no 289-1998-00	5-79
1A5Y6		CRYSTAL UNIT, QTZ: 83.33333 MHz, mfr 00136 part no 289-1991-00	5-79
1A5Y7		CRYSTAL UNIT, QTZ: 86.66667 MHz, mfr 00136 part no 289-1992-00	5-79
1A5Y8		CRYSTAL UNIT, QTZ: 90.00000 MHz, mfr 00136 part no 289-1993-00	5-79
1A5Y9		CRYSTAL UNIT, QTZ: same as 1A5Y2	5-79
1A5Y10		CRYSTAL UNIT, QTZ: 72.50000 MHz; mfr 00136 part no 289-2008-00	5-79
1A5Y11		CRYSTAL UNIT, QTZ: 75.00000 MHz, mfr 00136 part no 289-2009-00	5-79
1A5Y12		CRYSTAL UNIT, QTZ: 77.50000 MHz, mfr 00136 part no 289-2010-00	5-79
1A5Y13		CRYSTAL UNIT, QTZ: same as 1A5Y5	5-79
1A5Y14		CRYSTAL UNIT, QTZ: 82.50000 MHz; mfr 00136 part no 289-2011-00	5-79
1A5Y15		CRYSTAL UNIT, QTZ: 85.00000 MHz; mfr 00136 part no 289-2012-00	5-79
1A5Y16		CRYSTAL UNIT, QTZ: 87.50000 MHz, mfr 00136 part no 289-2013-00	5-79
1A5Y17		CRYSTAL UNIT, QTZ: same as 1A5Y8	5-79
1A5Y18		CRYSTAL UNIT, QTZ: 92.50000 MHz, mfr 00136 part no 289-2014-00	5-79

## MODULATOR MODULE

1A6		MODULATOR, RAD XMTR 5W max power output; 300 to 3500 Hz, 80 ohms input, 3000 ohms output; 24.5V and 190V operating power, 1.437 in by 3.437 in by 3.562 in; mfr 13499 part no 528-0089-017	5-37
1A6C1		CAPACITOR, FXD, ELCTLT: MIL type CSR13F565KL	5-44
1A6C2		CAPACITOR, FXD, ELCTLT: MIL type CSR13B566KL	5-44
1A6C3		CAPACITOR, FXD, PR-MYLAR DIE: MIL type CQ09A1KF103K3	5-44
1A6C4		CAPACITOR, FXD, CER DIE: MIL type CK14AX103M	5-44
1A6E1		PRINTED CIRCUIT BOARD: plstc; 0.062 in by 1.750 in by 3 in, incl 54 tubeless; mfr 13499 part no 548-7014-005	5-44

ORIGINAL



TABLE 6-2. (Continued)

## MODULATOR MODULE

REF DESIG	NOTE S	NAME AND DESCRIPTION	FIG NO
1A6H1		WASHER glass cloth, silicone rbr; 0.086 in ID, 0.750 in OD, 0.0050 in thk; mfr 13499 part no 547-2288-003	5-44
1A6H2		SCREW, SHOULDER, NO 2 CRES, passivate finish 8-32 UNC-2A thd, 0.127 in hex, 0.270 in dia 3.584 in lg, mfr 13499 part no 544-8223-002	5-44
1A6H3		SPACER, SLV al, chromate dip 0.031 in wall, 0.125 in lg, 0.156 in OD; mfr 13499 part no 541-5949-002	5-44
1A6J1		JACK, TIP: WHT, mfr 98291 part no SKT41WHITE	5-44
1A6J2		JACK, TIP same as 1A6J1	5-44
1A6MP1		BASE, X STR al, 11/16-24 ext thd, 0.265 in lg, 0.391 in lg o/a, mfr 13499 part no 548-7002-002	5-44
1A6MP2		CAP, XSTR al; 11/16-24 intl thd, 3/4 in dia by 7/16 in lg, mfr 13499 part no 548-7003-002	5-44
1A6MP3		INSULATOR, BUSHING: plstc, 0.313 in dia by 0.150 in lg; 0.177 in ID undercut to 0.096 m; mfr 13499 part no 548-7004-002	5-44
1A6MP4		COVER, MODULATOR al, chromate dip finish; 0.032 in by 3.209 in by 3.437 in, mfr 13499 part no 548-7000-003	5-44
1A6P1		CONNECTOR mfr 71468 part no DEMM9P	5-44
1A6Q1		TRANSISTOR MIL-S-19500/180(SIGC) type 2N1486	5-44
1A6Q2		TRANSISTOR: same as 1A6Q1	5-44
1A6Q3		TRANSISTOR: same as 1A6Q1	5-44
1A6R1		RESISTOR, FXD, CMPSN MIL-R-11 type RC07GF101K	5-44
1A6R2		RESISTOR, VAR, WW: MIL-R-27208 type RT12C2L102	5-44
1A6R3		RESISTOR, FXD, CMPSN: MIL-R-11 type RC20GF682K	5-44
1A5R4		RESISTOR, FXD, CMPSN MIL-R-11 type RC07GF821K	5-44
1A6R5		RESISTOR, FXD, CMPSN MIL-R-11 type RC07GF470K	5-44
1A6R6		RESISTOR, FXD, WW: MIL-R-26 type RW69V431	5-44
1A6R7		RESISTOR, FXD, CMPSN same as 1A6R5	5-44
1A6R8		RESISTOR, FXD, CMPSN MIL-R-11 type RC20GF272K	5-44
1A6R9		RESISTOR, FXD, WW MIL-R-26 type RW69V8R2	5-44
1A5R10		RESISTOR, FXD, CMPSN MIL-R-11 type RC07GF154K	5-44
1A6R11		RESISTOR, FXD, CMPSN-MIL-R-11 type RC07GF153K	5-44
1A6R12		RESISTOR, FXD, CMPSN: same as 1A6R4	5-44
1A6RT1		RESISTOR, THRM 330 ohms +10%, 1W, mfr 10646 part no 763F89	5-44
1A6T1		TRANSFORMER mfr 73386 part no 38802	5-44
1A6T2		TRANSFORMER mfr 80008 part no E15279	5-44

## GUARD RECEIVER MODULE

1A7		RECEIVER, RADIO: mfr 13499 part no 528-0090-005	5-37
1A7C1		CAPACITOR, VAR, GLASS DIELECT: 0.8PF to 8.0PF, 1000V, mfr 73899 part no VCJ705	5-48
1A7C2		CAPACITOR, FXD, CER DIELECT: MIL type CC22CH100D	5-48
1A7C3		NOT USED	
1A7C4		CAPACITOR, FXD, CER DIELECT: 7.0PF to 1/4PF, 500V; mfr 72982 part no 331026C0H0709C	5-48
1A7C5		CAPACITOR, FXD, MICA DIELECT: 1000PF, $\pm 5\%$ , 100V, mfr 72136 part no DM15E102J0100WV4CR	5-48

ORIGINAL

**TABLE 6-2. (Continued)**

GUARD RECEIVER MODULE

REF DESIG	NOTE S	NAME AND DESCRIPTION	FIG NO
1A7C6		CAPACITOR, VAR, GLASS DIELECTRIC: same as 1A7C1	5-48
1A7C7		CAPACITOR, FXD, CER DIELECTRIC: 6.0PF to 1/2PF, 500V, mfr 72982 part no 301626C0H0609D	5-48
1A7C8		CAPACITOR, FXD, CER DIELECTRIC: 1000PF, GMV, 500V; mfr 72982 part no 2465009W5T0102P	5-48
1A7C9		CAPACITOR, FXD, CER DIELECTRIC: 2PF to 1/2PF, 500V, mfr 72982 301626C0K0209D	5-48
1A7C10		CAPACITOR, FXD, MICA DIELECTRIC: same as 1A7C5	5-48
1A7C11		CAPACITOR, FXD, CER DIELECTRIC: same as 1A7C8	5-48
1A7C12		CAPACITOR, VAR, GLASS DIELECTRIC: same as 1A7C1	5-48
1A7C13		CAPACITOR, FXD, CER DIELECTRIC: 10PF to 1/2PF, 500V, mfr 72982 part no 331026C0H0100D	5-48
1A7C14		CAPACITOR, FXD, CER DIELECTRIC: 0.5PF to 1/4PF, 500V, mfr 72982 part no 331026C0K0508C	5-48
1A7C15		CAPACITOR, FXD, CER DIELECTRIC: 7.0PF to 1/2PF, 500V, mfr 72982 part no 301626C0H0709D	5-48
1A7C16		CAPACITOR, VAR, GLASS DIELECTRIC: same as 1A7C1	5-48
1A7C17		CAPACITOR, FXD, CER DIELECTRIC: same as 1A7C9	5-48
1A7C18		CAPACITOR, FXD, MICA DIELECTRIC: MIL type CM05E470J03	5-48
1A7C19		CAPACITOR, FXD, CER DIELECTRIC: MIL type CK14AX103M	5-48
1A7C20		CAPACITOR, FXD, CER DIELECTRIC: same as 1A7C19	5-48
1A7C21		CAPACITOR, FXD, CER DIELECTRIC: 18PF, ±10% 500V, mfr 72982 part NO 331026COH0180K	5-48
1A7C22		CAPACITOR, VAR, GLASS DIELECTRIC: same as 1A7C1	5-48
1A7C23		CAPACITOR, FXD, CER DIELECTRIC: same as 1A7C13	5-48
1A7C24		CAPACITOR, FXD, CER DIELECTRIC: same as 1A7C9	5-48
1A7C25		CAPACITOR, FXD, CER DIELECTRIC: MIL-C-20D type CC20TJ060D	5-48
1A7C26		CAPACITOR, FXD, CER DIELECTRIC: 1500PF, ±10%, 500V, mfr 56289 part no 29C155A2	5-48
1A7C27		CAPACITOR, FXD, MICA DIELECTRIC: MIL type CM05E200J03	5-48
1A7C28		CAPACITOR, FXD, CER DIELECTRIC: same as 1A7C26	5-48
1A7C29		CAPACITOR, FXD, CER DIELECTRIC: same as 1A7C19	5-48
1A7C30		CAPACITOR, FXD, CER DIELECTRIC: same as 1A7C19	5-49
1A7C31		NOT USED	
1A7C32		CAPACITOR, FXD, CER DIELECTRIC: 10PF to 1/2PF, 500V, mfr 72982 part no 331026COH0100D	5-45
1A7C33		CAPACITOR, FXD, CER DIELECTRIC: same as 1A7C19	5-49
1A7C34		CAPACITOR, FXD, CER DIELECTRIC: 27PF, ±10%, 500V, mfr 71590 part no 2DTM22L270K	5-45
1A7C35		CAPACITOR, FXD, CER DIELECTRIC: same as 1A7CD	5-45
1A7C36		CAPACITOR, FXD, CER DIELECTRIC: same as 1A7C19	5-46
1A7C37		CAPACITOR, FXD, CER DIELECTRIC: same as 1A7C21	5-46
1A7C38		CAPACITOR, FXD, CER DIELECTRIC: same as 1A7C19	5-46
1A7C39		CAPACITOR, FXD, CER DIELECTRIC: same as 1A7C8	5-45
1A7C40		CAPACITOR, FXD, CER DIELECTRIC: same as 1A7C8	5-45
1A7C41		CAPACITOR, FXD, CER DIELECTRIC: same as 1A7C19	5-46
1A7C42		CAPACITOR, FXD, CER DIELECTRIC: same as 1A7C21	5-46
1A7C43		CAPACITOR, FXD, CER DIELECTRIC: same as 1A7C19	5-46
1A7C44		CAPACITOR, FXD, CER DIELECTRIC: same as 1A7C8	5-45

ORIGINAL

TABLE 6-2. (Continued)

## GUARD RECIEVER MODULE

REF DESIG	NOTE S	NAME AND DESCRIPTION	FIG NO
1A7C45		CAPACITOR, FXD, CER DIELECTRIC: same as 1A7C8	5-46
1A7C46		CAPACITOR, FXD, CER DIELECTRIC: same as 1A7C19	5-46
1A7C47		CAPACITOR, FXD, CER DIELECTRIC: same as 1A7C21	5-46
1A7C48		CAPACITOR, FXD, CER DIELECTRIC: same as 1A7C19	5-46
1A7C49		CAPACITOR, FXD, CER DIELECTRIC: same as 1A7C9	5-48
1A7C50		CAPACITOR, FXD, CER DIELECTRIC: same as 1A7C8	5-45
1A7C51		CAPACITOR, FXD, CER DIELECTRIC: same as 1A7C19	5-46
1A7C52		CAPACITOR, FXD, CER DIELECTRIC: same as 1A7C19	5-46
1A7C53		NOT USED	
1A7C54		CAPACITOR, FXD, CER DIELECTRIC: same as 1A7C21	5-46
1A7C55		CAPACITOR, FXD, ELCTLT: 22UF, $\pm 20\%$ , 35V, mfr 56289 part no 150D226X0035R2	5-48
1A7C56		CAPACITOR, FXD, ELCTLT: 2.2UF, $\pm 20\%$ , 20V, mfr 56289 part no 150D225X0020A2	5-45
1A7C57		CAPACITOR, FXD, ELCTLT: 10UF, $\pm 20\%$ , 20V, mfr 56289 part no 150D106X0020B2	5-45
1A7C58		CAPACITOR, FXD, CER DIELECTRIC: CK12AX102M	5-45
1A7C59		CAPACITOR, FXD, ELCTLT: 0.10UF, $\pm 20\%$ , 35V, mfr 56289 part no 150D104X0035A2	5-49
1A7C60		CAPACITOR, FXD, ELCTLT: 1.0UF, $\pm 20\%$ , 35V, mfr 56289 part no 150D105X0035A2	5-49
1A7C61		CAPACITOR, FXD, ELCTLT: same as 1A7C56	5-49
1A7C62		CAPACITOR, FXD, CER DIELECTRIC: same as 1A7C58	5-45
1A7C63		CAPACITOR, FXD, CER DIELECTRIC: same as 1A7C8	5-48
1A7C64		CAPACITOR, FXD, CER DIELECTRIC: same as 1A7C8	5-48
1A7C65		CAPACITOR, FXD, CER DIELECTRIC: same as 1A7C19	5-45
1A7C66		CAPACITOR, FXD, CER DIELECTRIC: same as 1A7C19	5-45
1A7C67		CAPACITOR, FXD, MICA DIELECTRIC: MIL type CM05FIOIJO3	5-48
1A7C68		CAPACITOR, FXD, CER DIELECTRIC: same as 1A7C19	5-48
1A7C69		CAPACITOR, FXD, CER DIELECTRIC: same as 1A7C58	5-48
1A7C70		CAPACITOR, FXD, CER DIELECTRIC: same as 1A7C58	5-48
1A7C71		CAPACITOR, FXD, CER DIELECTRIC: same as 1A7C26	5-48
1A7C72		CAPACITOR, FXD, ELCTLT: 4.7UF, $\pm 20\%$ , 35V, mfr 56289 part no 150D475X0035B2	5-48
1A7C73		CAPACITOR, FXD, ELCTLT: same as 1A7C72	5-48
1A7C74		CAPACITOR, FXD, MICA DIELECTRIC: MIL type CM05D181JO3	5-45
1A7C75		CAPACITOR, FXD, CER DIELECTRIC: same as 1A7C32	5-47
1A7C76		CAPACITOR, FXD, CER DIELECTRIC: same as 1A7C32	5-47
1A7C77		CAPACITOR, FXD, CER DIELECTRIC: same as 1A7C58	5-47
1A7C78		CAPACITOR, FXD, CER DIELECTRIC: same as 1A7C56	5-45
*1A7CR1		SEMICONDUCTOR DEVICE: MIL-S-19500/127 (NAVY) type 1N747A	5-49
*1A7CR1		SEMICONDUCTOR DEVICE: MIL-S-19500/127 (NAVY) type 1N749A	5-49
*1A7CR1		SEMICONDUCTOR DEVICE: MIL-S-19500/127 (NAVY) type 1N751A	5-49
*1A7CR1		SEMICONDUCTOR DEVICE: MIL-S-19500/127 (NAVY) type 1N753A	5-49
*1A7CR1		SEMICONDUCTOR DEVICE: MIL-S-19500/127 (NAVY) type 1N754A	5-49
1A7CR2		SEMICONDUCTOR DEVICE: MIL-E-1 type 1N457	5-49
1A7CR3		SEMICONDUCTOR DEVICE: MIL-E-1/258 (NAVY) type 1N753A	5-45
1A7CR4		SEMICONDUCTOR DEVICE: same as 1A7CR3	5-48

\* Chosen per operational requirements,

ORIGINAL

**TABLE 6-2. (Continued)**

## GUARD RECEIVER MODULE

REF DESIG	NOTE S	NAME AND DESCRIPTION	FIG NO
1A7CR5		SEMICOND DEVICE: MIL-S-19500/115 (NAVY) type 1N3027B	5-48
1A7CR6		SEMICOND DEVICE: mfr 03877 part no. 1N816	5-45
1A7CR7		SEMICOND DEVICE: MIL-D-19500/188 type 1N251	5-48
1A7FL1		FILTER: mfr 00136 part no 2B5	5-45
1A7FL2		FILTER: mfr 01121 part no SMFB2A2	5-48
1A7H1		NUT, PL, HEX: al, chromate dip; 0.1875 in hex; 4-40 UNC-2B thd, 0.643 in lg, mfr 13499 part no 548-7153-002	5-47
1A7H2		NUT, PL, HEX: al, chromate dip; 0.1875 in hex; 4-40 UNC-2B thd, 0.615 in lg, mfr 13499 part no 548-7171-002	5-45
1A7H3		SCREW, SHOULDER: CRES, passivate finish 0.125 in ID, 0.250 in OD, 3.578 in lg; mfr 13499 part no 548-7159-002	5-48
1A7J1		JACK, TIP: BRN: mfr 98291 part no SKT-41BROWN	5-48
1A7J2		JACK, TIP: RED: mfr 98291 part no SKT-10RED	5-45
1A7L1		COIL, RF: single layer wound type; 3 turns of no 16 AWG wire; mfr 13499 part no 548-7156-002	5-47
1A7L2		COIL, RF: single layer wound type; 3 turns of no 18 AWG wire, mfr 13499 part no 548-7157-002	5-47
1A7L3		COIL, RF: same as 1A7L2	5-47
1A7L4		COIL, RF: same as 1A7L2	5-47
1A7L5		COIL, RF: MIL type LT4K029	5-47
1A7L6		COIL, RF: single layer wound type; 21 turns of no 36 AWG wire, mfr 13499 part no 548-7155-002	5-47
1A7L7		COIL, RF: same as 1A7L2	5-47
1A7L8		COIL, RF: MIL type LT4K030	5-47
1A7L9		NOT USED	
1A7L10		COIL, RF: single layer wound type; 7 turns of no 26 AWG wire; mfr 13499 part no 548-7579-003	5-47
1A7L11		COIL, RF: same as 1A7L6	5-47
1A7L12		COIL, RF: same as 1A7L6	5-46
1A7L13		COIL, RF: same as 1A7L6	5-46
1A7L14		COIL, RF: same as 1A7L6	5-46
1A7L15		COIL, RF: same as 1A7L6	5-46
1A7L16		COIL, RF: single layer wound type; 15 turns of no 36 AWG wire; mfr 13499 part no 548-7136-002	5-45
1A7L17		COIL, RF: MIL type LT4K047	5-47
1A7L18		COIL, RF: same as 1A7L17	5-45
1A7L19		COIL, RF: same as 1A7L17	5-45
1A7L20		COIL, RF: same as 1A7L17	5-49
1A7L21		COIL, RF: same as 1A7L5	5-47
1A7L22		COIL, RF: same as 1A7L5	5-47
1A7MP1		GROMMET: mfr 93106 part no GB2156	5-48
1A7MP2		COVER, RCVR, NO 1: al, chromate dip, 0.063 in thk, 3.218 in dia, 4.406 in lg; mfr 13499 part no 548-7576-003	5-45
1A7MP3		COVER, RCVR NO 2: al, chromate dip; 0.063 in thk, 3.218 in dia, 4.406 in lg; mfr 13499 part no 548-7578-003	5-48
1A7P1		CONNECTOR: mfr 71468 part no DAM11W1PC27	5-45
1A7Q1		TRANSISTOR. mfr 07688 part no 2N917	5-48
1A7Q2		TRANSISTOR. Same as 1A7Q1	5-48
1A7Q3		TRANSISTOR: same as 1A7Q1	5-48
1A7Q4		TRANSISTOR: same as 1A7Q1	5-48

ORIGINAL

TABLE 6-2. (Continued)

## GUARD RECIEVER MODULE

REF DESIG	NOTE S	NAME AND DESCRIPTION	FIG NO
1A7Q5		TRANSISTOR: MIL-S-19500/80A(SIGC) type 3N35	5-48
1A7Q6		TRANSISTOR: same as 1A7Q5	5-46
thru 1A7Q9			
1A7Q10		TRANSISTOR:-mfr 07688 part no. 2N706	5-45
1A7Q11		TRANSISTOR: MIL-S-19500/111(SIGC) type 2N329A	5-45
1A7Q12		TRANSISTOR: MIL-S-19500/99A(SIGC) type 2N697	5-45
1A7Q13		TRANSISTOR: MIL-S-19500/120(SIGC) type 2N706	5-45
1A7Q14		TRANSISTOR: same as 1A7Q12	5-48
1A7Q15		TRANSISTOR: same as 1A7Q11	5-45
1A7R1		RESISTOR, FXD, CMPSN: MIL-R-11 type RC07GF103K	5-47
1A7R2		RESISTOR, FXD, CMPSN: MIL-R-11 type RC07GF222K	5-47
1A7R3		RESISTOR, FXD, CMPSN: MIL-R-11 type RC07GF102K	5-47
1A7R4		RESISTOR, FXD, CMPSN: same as 1A7R1	5-47
1A7R5		RESISTOR, FXD, CMPSN: same as 1A7R2	5-47
1A7R6		RESISTOR, FXD, CMPSN: same as 1A7R3	5-47
1A7R7		RESISTOR, FXD, CMPSN: MIL-R-11 type RC07GF223K	5-47
1A7R8		RESISTOR, FXD, CMPSN: same as 1A7R2	5-47
1A7R9		RESISTOR, FXD, CMPSN: MIL-R-11 type RC07GF152K	5-47
1A7R10		RESISTOR, FXD, CMPSN: same as 1A7R1	5-47
1A7R11		RESISTOR, FXD, CMPSN same as 1A7R1	5-47
1A7R12		RESISTOR, FXD, CMPSN: MIL-R-11 type RC07GF182K	5-47
1A7R13		RESISTOR, FXD, CMPSN: MIL-R-11 type RC07GF104K	5-47
1A7R14		RESISTOR, FXD, CMPSN: MIL-R-11 type RC07GF472K	5-47
1A7R15		RESISTOR, FXD, CMPSN: same as 1A7R3	5-49
1A7R16		RESISTOR, FXD, CMPSN: MIL-R-11 type RC07GF153K	5-49
1A7R17		RESISTOR, FXD, CMPSN: same as 1A7R14	5-47
1A7R18		RESISTOR, FXD, CMPSN: MIL-R-11 type RC07GF332K	5-49
1A7R19		RESISTOR, FXD, CMPSN: same as 1A7R7	5-49
1A7R20		RESISTOR, FXD, CMPSN: same as 1A7R2	5-47
1A7R21		RESISTOR, FXD, CMPSN: MIL-R-11 type RC07GF470K	5-45
1A7R22		RESISTOR, FXD, CMPSN: same as 1A7R3	5-46
1A7R23		RESISTOR, FXD, CMPSN: same as 1A7R16	5-46
1A7R24		RESISTOR, FXD, CMPSN: same as 1A7R14	5-46
1A7R25		RESISTOR, FXD, CMPSN: same as 1A7R18	5-46
1A7R26		RESISTOR, FXD, CMPSN: same as 1A7R7	5-46
1A7R27		RESISTOR, FXD, CMPSN: MIL-R-11 type RC07GF123K	5-47
1A7R28		RESISTOR, FXD, CMPSN: same as 1A7R3	5-46
1A7R29		RESISTOR, FXD, CMPSN: same as 1A7R16	5-46
1A7R30		RESISTOR, FXD, CMPSN: same as 1A7R14	5-46
1A7R31		RESISTOR, FXD, CMPSN: same as 1A7R18	5-46
1A7R32		RESISTOR, FXD, CMPSN: same as 1A7R7	5-46
1A7R33		NOT USED	
1A7R34		RESISTOR, FXD, CMPSN: same as 1A7R3	5-46
1A7R35		RESISTOR, FXD, CMPSN: same as 1A7R16	5-46
1A7R36		RESISTOR, FXD, CMPSN: same as 1A7R14	5-46
1A7R37		RESISTOR, FXD, CMPSN: same as 1A7R18	5-46
1A7R38		RESISTOR, FXD, CMPSN: same as 1A7R27	5-46

ORIGINAL

**TABLE 6-2. (Continued)**

GUARD RECEIVER MODULE

REF DESIG	NOTE S	NAME AND DESCRIPTION	FIG NO
1A7R39		RESISTOR, FXD, CMPSN: same as 1A7R27	5-49
1A7R40		RESISTOR, FXD, CMPSN: same as 1A7R3	5-46
1A7R41		RESISTOR, FXD, CMPSN: same as 1A7R16	5-46
1A7R42		RESISTOR, FXD, CMPSN: same as 1A7R14	5-46
1A7R43		RESISTOR, FXD, CMPSN: same as 1A7R18	5-46
1A7R44		RESISTOR, FXD, CMPSN: same as 1A7R7	5-46
1A7R45		RESISTOR, FXD, CMPSN: same as 1A7R2	5-45
1A7R46		RESISTOR, VAR, WW: 10K, $\pm 10\%$ , 0.8W; mfr 80294 part no 224L1-103	5-45
1A7R47		RESISTOR, FXD, CMPSN: MIL-R-11 type RC07GF154K	5-49
1A7R48		RESISTOR, FXD, CMPSN: same as 1A7R3	5-45
1A7R49		RESISTOR, FXD, CMPSN: MIL-R-11 type RC07GF221K	5-45
1A7R50		RESISTOR, FXD, CMPSN: same as 1A7R1	5-49
1A7R51		RESISTOR, FXD, CMPSN.: same as 1A7R3	5-45
*1A7R52		RESISTOR, FXD, CMPSN: MIL-R-11 type RC07GF472K	5-45
*1A7R52		RESISTOR, FXD, CMPSN: MIL-R-11 type RC07GF562K	5-45
*1A7R52		RESISTOR, FXD, CMPSN: MIL-R-11 type RC07GF392K	5-45
*1A7R53		RESISTOR, FXD, CMPSN: MIL-R-11 type RC07GF332K	5-45
*1A7R53		RESISTOR, FXD, CMPSN: MIL-R-11 type RC07GF392K	5-45
*1A7R53		RESISTOR, FXD, CMPSN: MIL-R-11 type RC07GF272K	5-45
*1A7R53		RESISTOR, FXD, CMPSN: MIL-R-11 type RC07GF272K	5-45
1A7R54		RESISTOR, FXD, CMPSN: same as 1A7R1	5-45
1A7R55		RESISTOR, FXD, CMPSN: same as 1A7R49	5-45
1A7R56		RESISTOR, FXD, CMPSN: same as 1A7R3	5-45
1A7R57		RESISTOR, FXD, CMPSN: same as 1A7R1	5-49
1A7R58		RESISTOR, FXD, CMPSN: same as 1A7R16	5-49
1A7R59		RESISTOR, FXD, CMPSN: MIL-R-11 type RC07GF823K	5-45
1A7R60		RESISTOR, FXD, CMPSN: same as 1A7R16	5-45
1A7R61		RESISTOR, FXD, CMPSN: same as 1A7R1	5-45
1A7R62		RESISTOR, FXD, CMPSN: same as 1A7R27	5-49
1A7R63		NOT USED	
*1A7R64		RESISTOR, FXD, CMPSN: MIL-R-11 type RC07GF823K	5-49
1A7R64		RESISTOR, FXD, CMPSN: MIL-R-11 type RC07GF124K	5-49
1A7R64		RESISTOR, FXD, CMPSN: MIL-R-11 type RC07GF154K	5-49
*1A7R64		RESISTOR, FXD, CMPSN: MIL-R-11 type RC07GF104K	5-49
1A7R65		RESISTOR, FXD, CMPSN: same as 1A7R2	5-47
1A7R66		RESISTOR, FXD, CMPSN: same as 1A7R21	5-47
1A7R67		RESISTOR, FXD, CMPSN: same as 1A7R14	5-45
1A7R68		RESISTOR, FXD, CMPSN: same as 1A7R14	5-45
1A7R69		RESISTOR, FXD, CMPSN: same as 1A7R14	5-45
1A7TB1		NOT USED	
1A7TB2		TERMINAL BOARD. plstc; incl 10 terminals, 0.062 in by 0.703 m by 1.687 in board dim, mfr 13499 part no 548-7181-003	5-48
1A7TB3		TERMINAL BOARD plstc; incl 5 terminals, 0.062 in by 1 in by 1.125 in board dim, mfr 13499 part no 548-7150-003	5-45
1A7TB4		TERMINAL BOARD: plstc, glass cloth, 1/16 in by 1-5/32 m by 2-9/64 in incl 23 terminals, mfr 13499 part no 548-7581-003	5-45
1A7Y1		CRYSTAL UNIT, QTZ 111.2250 mc; mfr 00136 part no 290-9602-00	5-47

\*Chosen per requirements

ORIGINAL

TABLE 6-2. (Continued)

## RF AND POWER AMPLIFIER MODULE

REF DESIG	NOTE S	NAME AND DESCRIPTION	FIG NO
1A8		AMPLIFIER, RF: 225 to 400 MHz freq range, mfr 13499 part no 528-0091-015	5-37
1A8C1		CAPACITOR, FXD, CER DIELECTRIC: 470PF, +20%, 500V; mfr 56289 part no 40C204A5	5-52
1A8C2		CAPACITOR, FXD, CER DIELECTRIC: 400PF, GMV at room temp, 360V, mfr 72982 part no 2404032W5P0401P	5-52
1A8C3		CAPACITOR, FXD, CER DIELECTRIC: same as 1A8C2	5-52
1A8C4		CAPACITOR, FXD, CER DIELECTRIC: same as 1A8C2	5-50
1A8C5		CAPACITOR, FXD, CER DIELECTRIC: same as 1A8C1	5-52
1A8C6		CAPACITOR, FXD, CER DIELECTRIC: MIL-C-20B type CC22CK1R5D	5-52
1A8C7		CAPACITOR, VAR, GLASS DIELECTRIC 0.75PF to 3PF, 500V; mfr 73899 part no VCJ134	5-50
1A8C8		CAPACITOR, FXD, CER DIELECTRIC: same as 1A8C2	5-52
1A8C9		CAPACITOR, FXD, CER DIELECTRIC: same as 1A8C1	5-52
1A8C10		CAPACITOR, FXD, CER DIELECTRIC: same as 1A8C2	5-50
1A8C11		CAPACITOR, FXD, CER DIELECTRIC: same as 1A8C6	5-52
1A8C12		CAPACITOR, VAR, GLASS DIELECTRIC: same as 1A8C7	5-50
1A8C13		CAPACITOR: FXD, CER DIELECTRIC: same as 1A8C2	5-50
1A8C14		CAPACITOR includes grid plate Collins Radio Company part no 548-7077-002, insulator Collins Radio Company part no 548-7102-003, bushing Collins Radio Company part no 548-7078-002	5-52
1A8C15		CAPACITOR, FXD, CER DIELECTRIC: MIL-C-20B type CC22CH200J	5-52
1A8C16		CAPACITOR, FXD, CER DIELECTRIC: same as 1A8C2	5-50
1A8C17		CAPACITOR, FXD, CER DIELECTRIC: MIL-C-20D type CC22UK020D	5-52
1A8C18		CAPACITOR, VAR, GLASS DIELECTRIC: same as 1A8C7	5-80
1A8C19		CAPACITOR, FXD, CER DIELECTRIC: same as 1A8C2	5-52
1A8C20		CAPACITOR includes grid plate Collins Radio Company part no 548-7077-002, insulator Collins Radio Company part no 548-7103-003, bushing Collins Radio Company part no 548-7078-002	5-50
1A8C21		CAPACITOR, VAR, GLASS DIELECTRIC: same as 1A8C7	5-50
1A8C22		CAPACITOR; includes 1A8MP29 and 1A8MP30 and 1A8MP32	5-51
1A8C23		CAPACITOR p/o 1A8MP25	5-80
1A8C24		CAPACITOR, FXD, CER DIELECTRIC: same as 1A8C2	5-50
1A8C25		CAPACITOR. includes grid plate Collins Radio Company part no 548-8570-003, insulator Collins Radio Company part no 548-7101-003, bushing Collins Radio Company part no 548-7078-002	5-50
1A8C26		CAPACITOR, FXD, CER DIELECTRIC: same as 1A8C1	5-51
1A8C27		CAPACITOR, VAR, AIR DIELECTRIC: single sect, 1.2PF to 5PF; mfr 97137 part no 875001	5-50
1A8C28		CAPACITOR. includes 1A8MP29 and 1A8MP30 and 1A8MP32	5-51
1A8C29		CAPACITOR, FXD, CER DIELECTRIC: same as 1A8C1	5-51
1A8C30		CAPACITOR, VAR, GLASS DIELECTRIC: 0.5PF to 2PF. 700V; includes mounting facilities, mfr 13499 part no 922-3007-00	5-80
1A8C31		CAPACITOR, FXD, CER DIELECTRIC: same as 1A8C2	5-50

ORIGINAL

TABLE 6-2. (Continued)

## RF AND POWER AMPLIFIER MODULE

REF DESIG	NOTE S	NAME AND DESCRIPTION	FIG NO
1A8C32		CAPACITOR, FXD, CER DIELECT: same as 1A8C2	5-50
1A8C33		CAPACITOR, FXD, CER DIELECT: same as 1A8C2	5-80
1A8C34		CAPACITOR, FXD, CER DIELECT: same as 1A8C2	5-52
1A8C35		CAPACITOR, FXD, CER DIELECT: same as 1A8C2	5-52
1A8C36		CAPACITOR, FXD, CER DIELECT: same as 1A8C2	5-52
1A8C37		CAPACITOR, FXD, CER DIELECT: same as 1A8C2	5-51
1A8C38		CAPACITOR, FXD, CER DIELECT: same as 1A8C2	5-52
1A8C39		CAPACITOR, FXD, ELCTLT MIL-C-3965 type CL23CH100TN3	5-80
1A8C40		CAPACITOR, FXD, CER DIELECT: MIL-C-20D type CC22TJ040D	5-50
1A8C41		CAPACITOR, FXD, CER DIELECT: same as 1A8C17	5-51
1A8E1		CONTACT, ELEC: cop, gold pl; 1-1/16 in dia by 1/4 in h, mfr 13499 part no 544-8407-002	5-51
1A8E2		ADAPTER, HEATER: 0.422 in dia by 0.234 in lg; mfr 13499 part no 540-8750-002	5-50
1A8H1		SCREW, SHOULDER, NO 2 CRES, passivate finish 8-32 UNC-2A thd, 0.127 in hex, 0.270 in dia, 3.584 in lg; mfr 13499 part no 544-8223-002	5-51
1A8H2		WASHER, FINISHING: cop, alloy-plated finish, 0.091 in ID, csk 82 deg. 0.212 in OD, 0.062 in thk; mfr 13499 part no 545-6590-002	5-52
1A8H3		WASHER, FLAT: cop, bright alloy 0.125 in ID, 0.250 in OD, 0.016 in thk; mfr 13499 part no 543-5575-003	5-51
1A8H4		NUT, SPCL: al, chromate dip, 4-40 UNC-2B thd, 5/16 in by 3/8 in mfr 13499 part no 548-7558-002	5-51
1A8H5		SETSCREW: stl, cd pl; fluted multiple spline cut point 2-56 NC-3A thd, 3/32 in lg, mfr 13499 part no 328-0368-00	5-51
1A8H6		SCREW, MACH: nylon, slotted filh, 4-40 UNC-2A thd, 3/8 in lg, mfr 13499 part no 330-2248-00	5-51
1A8H7		NUT, HEX: CRES, passivate finish, 7/16-32 UNC-2B thd, 0.5625 in hex, 0.062 in thk, mfr 13499 part no 544-8410-002	5-80
1A8J1		JACK TIP: WHT: mfr 98291 part no. SKT5BCWHITE	5-80
1A8J2 thru 1A8J11		JACK, TIP: same as 1A8J1	5-80
1A8K1		RELAY, AMT: 2C cont arrangement; 2 amp at 28 Vdc or 115 Vac; 550 ohms dc resistance, single layer wound; mfr 01526 part no 3SAE2053A2	5-80
1A8L1		COIL, RF: MIL type LT5K027	5-50
1A8L2		COIL, RF: MIL type LT4K030	5-50
1A8L3		COIL, RF: MIL type LT4K029	5-52
1A8L4		COIL, RF: same as 1A8L2	5-52
1A8L5		COIL, RF: same as 1A8L2	5-52
1A8L6		COIL, RF: same as 1A8L2	5-52
1A8L7		COIL, RF: same as 1A8L2	5-50
1A8L8		COIL, RF: same as 1A8L2	5-51
1A8L9		COIL, RF: same as 1A8L3	5-50
1A8L10		COIL, RF: same as 1A8L2	5-51
1A8L11		COIL, RF: same as 1A8L2	5-60
1A8L12		COIL, RF: same as 1A8L2	5-50
1A8L13		COIL, RF: single layer wound, 14 turns no 28 AWG, mfr 13499 part no 545-5671-002	5-52

ORIGINAL



TABLE 6-2. (Continued)

## RF AND POWER AMPLIFIER MODULE

REF DESIG	NOTES	NAME AND DESCRIPTION	FIG NO
1A8L14		COIL, RF: same as 1A8L13	5-52
1A8L15		COIL, RF: same as 1A8L13	5-52
1A8L16		COIL, RF: same as 1A8L2	5-50
1A8L17		COIL, RF: same as 1A8L2	5-50
1A8MP1		RING, plstc: 0.364 in ID, 0.504 in OD, 0.070 in thk, mfr 78189 part no 213-141216-00-2303	5-51
1A8MP2		BEARING: mfr 40920 part no S5632CHHP28L02	5-51
1A8MP3		BEARING: mfr 40920 part no S5632FCHHP37L01	5-80
1A8MP4		COUPLING, SHAFT, FLEX: CRES; coupling and insert 0.938 in dia by 0.189 in lg, mfr 13499 part no 540-8152-002	5-80
1A8MP5		INSERT, FLEX: COUPLING plstc: 0.938 in dia by 0.185 in lg; mfr 13499 part no 548-7038-002	5-80
1A8MP6		COLLAR, SHAFT: al, chromate dip; 0.135 in by 0.228 in by 0.375 in; mfr 13499 part no 544-7442-002	5-51
1A8MP7		ARM, CAM: plstc; 0.187 in by 0.250 in by 1.094 in; mfr 13499 part no 548-7055-002	5-51
1A8MP8		HUB, GROUNDING: brs, gold and rhodium pl; 0.187 in ID, 0.270 in OD, 0.174 in lg; mfr 13499 part no 544-7446-002	5-51
1A8MP9		STATOR, SWITCH: ceramic Insulator, sil pl brs cons; 0.532 in by 1 203 in by 1.546 in o/a dim; mfr 13499 part no 547-1692-003; Interchangeable with old MP9	5-52
1A8MP10		ROTOR ASSY: 0.535 in by 0.593 in by 1.186 in o/a approx; mfr 13499 part no 544-7450-002	5-52
1A8MP11		CONTACT, ELEC: cop "/gold-plated finish, 12 slots spaced 30 deg apart; 0.484 in dia, 0.005 in thk; mfr 13499 part no 544-7455-003	5-52
1A8MP12		HOUSING, BEARING: CRES; 7/16-32 ext thd; 0.234 in lg o/a, 0.313 in ID undercut to 0.234 in dia, mfr 13499 part no 544-8408- 002	5-80
1A8MP13		SPRING, RETAINING, CONT: CRES, passivate finish, 0.406 in ID, 0.430 in OD, 0.024 in thk; mfr 13499 part no 544-8520-002	5-51
1A8MP14		SHAFT: gold-plated brs shaft; 0.250 in dia by 3.500 in lg, mfr 13499 part no 548-7227-003	5-52
1A8MP15		INSULATOR, BLOCK: plstc; 0.625 in by 0.656 in by 0.843 in, incl contacts, terminals and clips, mfr 13499 part no. 548-7048-002	5-50
1A8MP16		COVER, AMPL: al, chromate dip finish. 0.032 in by 3.190 in by 4.359 in mfr 13499 part no 548-7051-002	5-80
1A8MP17		COVER, AMPL: al, chromate dip, 0.032 in by 3.190 in by 3.375 in mfr 13499 part no 548-7052-002	5-80
1A8MP18		COVER, AMPL: al, chromate dip finish; 0.032 in by 3.190 in by 3.375 in mfr 13499 part no 548-7053-002	5-80
1A8MP19		COVER, AMPL: al, 0.032 in by 3.190 in by 4.359 in mfr 13499 part no 548-7063-002	5-80
1A8MP20		INSULATOR, BLOCK: plstc; 0.468 in by 0.656 in by 0.688 in incl contacts, terminals and clips; mfr 13499 part no 548-7054-002	5-52
1A8MP21		GEARSHAFT, SPUR: plstc, 36 teeth; 0.791 in dia by 0.531 in lg; mfr 13499 part no 548-7064-002	5-52
1A8MP22		GEARSHAFT, SPUR: CRES; 58 teeth, 1.250 in dia by 0.719 in lg; mfr 13499 part no 548-7065-002	5-80
1A8MP23		GEAR, SPUR: plstc; 0.187 in ID, 1.250 in OD, 0.250 in lg, 58 teeth, mfr 13499 part no 548-7066-002	5-51

ORIGINAL

TABLE 6-2. (Continued)

## RF AND POWER AMPLIFIER MODULE

REF DESIG	NOTE S	NAME AND DESCRIPTION	FIG NO
1A8MP24		CAM, CONTROL: brs, gold and rhodium pl, 0.437 in dia by 0.250 in lg, mfr 13499 part no 548-7073-002	5-51
1A8MP25		CLIP ASSY, ELECTRON TUBE. 0.718 in by 0.750 in by 1.281 in approx o/a dim, mfr 13499 part no 548-7076-002	5-50
1A8MP26		SPACER, SLV, Long al, chromate dip, 0.120 in by 0.250 in by 0.437 in mfr 13499 part no 548-7079-002	5-51
1A8MP27		SPACER, SLV, SHORT. al, chromate dip; 0.120 in by 0.125 in by 0.250 in mfr 13499 part no 548-7081-002	5-51
1A8MP28		PLATE, GEAR: al, chromate dip finish 0.312 in by 2.219 in by 3.188 in mfr 13499 part no 548-7104-003	5-80
1A8MP29		ROTOR ASSY, CAPACITOR 0.531 in by 0.937 in by 1 218 m approx o/a, mfr 13499 part no 548-7105-003, p/o 1A8C22, 1A8C28	5-51
1A8MP30		STATOR ASSY, GRID-0.998 in by 1 656 in by 2 501 in approx, mfr 13499 part no 648-7115-004, p/o 1A8C22, 1A8C28	5-51
1A8MP31		STATOR ASSY, PLATE 0.265 in by 1.781 in by 2.671 in approx; mfr 13499 part no 548-7116-004	5-51
1A8MP32		SHAFT ASSY, CAPACITOR sil pl brs shaft and rotor sly, coin sil cont sly; 0.437 in dia by 3.347 in lg; mfr. 13499 part no 548-7123-004	5-51
1A8MP33		PLATE, BOTTOM: al; 0.187 in by 3.375 in by 4.375 m, Incl hdw, mfr 13499 part no 548-7125-005	5-51
1A8MP34		PLATE, TOP al, 0.187 in by 3.375 in by 4.375 in mfr 13499 part no 548-7127-005	5-51
1A8MP35		SPACER, SLV, AMT: al, chromate dip, 0.089 in by 0.140 in by 0.250 in mfr 13499 part no 548-7057-002	5-51
1A8MP36		CLAMP, TUBE: sil pl brs; 0.234 in by 0.375 in by 0.672 in mfr 13499 part no 548-7237-002	5-50
1A8MP37		BLOCK, MTG CONN: brs, sil pl, 0.138 in by 0.375 in by 0.906 in mfr 13499 part no 548-7430-002	6-50
1A8MP38		INSERT, SCREW THD al, chromate dip finish 0.250 in w across flats by 0.128 in lg, 2-56 thd, mfr 13499 part no 548-7061-002	5-51
1A8MP39		SPACER, SLV al, chromate dip, 0.031 in wall, 0.156 in OD, 0.312 in lg, mfr 13499 part no 541-5955-002	5-50
1A8MP40		SPACER, SLV al, chromate dip; 0.031 in wall, 0.156 in OD, 0.375 in lg, mfr 13499 part no 541-5957-002	5-80
1A8MP41		GEAR, SPUR al, 58 teeth; 0.187 in ID, 0.250 in OD, 0.250 in lg, mfr 13499 part no 548-7067-002	5-52
1A8MP42		BRACKET al, chromate dip finish, 1-3/8 in by 1-11/32 in by 6-1/8 in mfr 13499 part no 544-6904-002	5-51
1A8P1 P2 thru P11		CONNECTOR mfr 71468 part no DBM21WIPC27 NOT USED	5-80
1A8P12		CONNECTOR: mfr 98278 part no 052-0471	5-80
1A8Q1		TRANSISTOR MIL-S-19500/207(SIGC) type 2N1481	5-80
1A8R1		RESISTOR, FXD, CMPSN: MIL-R-11 type RC07GF105K	5-52
1A8R2		RESISTOR, FXD, CMPSN: MIL-R-11 type RC07GF820K	5-50
1A8R3		RESISTOR, FXD, CMPSN :MIL-R-11 type RC20GF105K	5-52
1A8R4		RESISTOR, FXD, CMPSN: same as 1A8R2	5-52
1A8R5		RESISTOR, FXD, CMPSN: same as 1A8R1	5-50
1A8R6		RESISTOR, FXD, CMPSN: MIL-R-11 type RC07GF101K	5-60

ORIGINAL

TABLE 6-2. (Continued)

## RF AND POWER AMPLIFIER MODULE

REF DESIG	NOTES	NAME AND DESCRIPTION	FIG NO
1A8R7		RESISTOR, FXD, CMPSN: same as 1A8R1	5-52
1A8R8		RESISTOR, FXD, CMPSN: MIL-R-11 type RC20GF471K	5-52
1A8R9		RESISTOR, FXD, CMPSN: same as 1A8R1	5-50
1A8R10		RESISTOR, FXD, CMPSN: MIL-R-11 type RC20GF151K	5-50
1A8R11		RESISTOR, FXD, CMPSN: same as 1A8R1	5-50
1A8R12		RESISTOR, FXD, CMPSN: same as 1A8R8	5-50
1A8R13		RESISTOR, FXD, CMPSN: same as 1A8R1	5-50
1A8R14		RESISTOR, FXD, CMPSN: MIL-R-11 type RC20GF330K	5-50
1A8R15		RESISTOR, FXD, CMPSN: same as 1A8R1	5-50
1A8R16		RESISTOR, FXD, CMPSN: MIL-R-11 type RC20GF331K	5-50
1A8R17		RESISTOR, FXD, CMPSN: MIL-R-11 type RC20GF681K	5-50
1A8R18		RESISTOR, FXD, WW: 10 ohms, $\pm 1\%$ , 2.5W, mfr 91637 part no RSM2C10R00F	5-80
1A8R19		RESISTOR, FXD, WW: MIL-R-26 type RW67V272	5-80
1A8R20		RESISTOR, FXD, CMPSN: MIL-R-11 type RC07GF472K	5-80
1A8R21		RESISTOR, FXD, CMPSN: MIL-R-11 type RC07GF103K	5-80
1A8R22		RESISTOR, FXD, CMPSN: MIL-R-11 type RC07GF332K	5-80
1A8R23		RESISTOR, FXD, CMPSN: MIL-R-11 type RC32GF222K	5-80
1A8R24		RESISTOR, FXD, WW: MIL-R-26 type RW67V182	5-80
1A8R25		RESISTOR, FXD, CMPSN: MIL-R-11 type RC42GF472K	5-80
1A8R26		RESISTOR, FXD, CMPSN: same as 1A8R25	5-80
1A8TB1		TERMINAL BOARD: plstc, 0.062 in by 0.938 in by 1.313 in; incl 4 terminals, mfr 13499 part no 548-7034-002	5-80
1A8V1		ELECTRON TUBE: MIL-E-1 type 7077	5-50
1A8V2		ELECTRON TUBE: same as 1A8V1	5-50
1A8V3		ELECTRON TUBE: MIL-E-1 type 7554	5-52
1A8V4		ELECTRON TUBE: same as 1A8V3	5-50
1A8V5		ELECTRON TUBE: MIL-E-1C type 6442	5-52
1A8XV1		SOCKET: mfr 04435 part no 86-001	5-52
1A8XV2		SOCKET: mfr 04435 part no 86-071	5-52

## RECEIVER AND TRANSMITTER SUBASSEMBLY

1A9		RECEIVER-TRANSMITTER SUBASSEMBLY: mfr 13499 part no 772-8142-001	5-37
1A9A1		AMPLIFIER, AC VOLTAGE: 28 Vdc supply voltage, 400 to 550 ohms input impedance 220-j 66 ohms output impedance, 5 ma-nom load current, 5 to 29K Hz freq response, mfr code 13499 part no 767-1964-001	5-82
1A9A2		AMPLIFIER, AC VOLTAGE same as 1A9A1	5-82
1A9C1		CAPACITOR, FXD, ELCTLT: (tantalum) 33UF, $\pm 20\%$ , 35V, code 56289 part no 150D336X0035S2	5-83
1A9C2		CAPACITOR, FXD, ELCTLT: same as 1A9C1	5-81
1A9C3		CAPACITOR, FXD, MICA DIEL: MIL type CM05E394J03	5-83
1A9C4		CAPACITOR, FXD, MICA DIEL: MIL type CM05E200J03	5-83
1A9C5		CAPACITOR, FXD, ELCTLT: MIL type CK14AX103M	5-83
1A9C6		CAPACITOR, FXD, CER DIEL: MIL type CK12AX102M	5-82
1A9CR1		SEMICONV DEVICE: mfr 80131 part no 1N916	5-83

ORIGINAL

TABLE 6-2. (Continued)

## RECEIVER AND TRANSMITTER SUBASSEMBLY

REF DESIG	NOTE S	NAME AND DESCRIPTION	FIG NO
1A9CR2		SEMICONV DEVICE: JEDEC type 1N1358A	5-81
CR3		NOT USED	5-81
1A9CR4		SEMICONV DEVICE: MIL-E-1/1143 type 1N647	5-81
1A9CR5		SEMICONV DEVICE: same as 1A9CR4	5-83
1A9CR6		SEMICONV DEVICE: same as 1A9CR4	5-83
1A9CR7		SEMICONV DEVICE: same as 1A9CR4	5-54
1A9CR8		SEMICONV DEVICE: mfr 81483 part no 69-1020-10Z6-3	5-81
1A9CR9		SEMICONV DEVICE: same as 1A9CR4	5-54
1A9CR10		SEMICONV DEVICE: same as 1A9CR4	5-54
1A9DS1		LAMP: MIL type MS25237-327	5-81
1A9DS2		LAMP: same as 1A9DS1	5-81
1A9E1		CONTACT ASSY, ELEC: 0.342 in by 1.125 in by 2.062 in o/a dim, mfr 13499 part no 548-7516-003; c/o 1A9J1, 1A9J2, 1A9J3	5-81
1A9F1		FUSE: MIL type F02A450V4AS	5-81
1A9F2		FUSE: same as 1A9F1	5-81
1A9FL1		FILTER, RAD INTRF: 5500PF, GMV, 200V; mfr 01121 part no SMFB-A2	5-81
1A9FL2 thru 1A9FL7 1A9FL8		FILTER, RAD INTRF: same as 1A9FL1	5-81
1A9FL9 thru 1A9FL12 1A9H1		FILTER, HIGH PASS-LOW PASS: 200 to 400 MHz passband, 10W pwr rating in passband; 0.750 in by 1.125 in by 3.875 in o/a dim excl connectors; mfr 13499 part no 241-0467-00	5-53
1A9H2		FILTER, RAD INTRF: same as 1A9FL1	5-81
1A9H3		WASHER: glass cloth, silicone rbr; 0.086 in ID, 0.750 in OD, 0.0050 in thk, mfr 13499 part no 547-2288-003	5-81
1A9H4		NOT USED	
1A9H5		SHIM: brs, chemical film finish 0.1875 in ID by 0.344 in OD by 0.005 in thk, mfr 13499 part no 553-5050-003	5-81
1A9H6		NOT USED	
1A9H7		SCREW, MACH: sst; Phillips recessed fil kid; 8-32NC-2A thd 1 in lg; mfr 13499 part no 548-7531-002	5-81
1A9H8		NOT USED	
1A9H9		WASHER, STOP: al, 0.080 in by 0.342 in by 0.571 in o/a dim; mfr 13499 part no 548-7498-002	5-83
1A9J1		WASHER, NM: plstc, 0.88 in ID, 0.150 in OD, mfr 76854 part no 15517	5-83
1A9J2		SHIM: plstc; 0.010 in thk by 1.031 in dia o/a dim; mfr 13499 part no 548-7350-002	5-83
1A9J3		CONTACT, ELEC: sil-pl cop cont surface; 0.187 in dia by 0.342 in lg o/a dim; mfr 13499 part no 548-7447-002, p/o 1A9E1	5-81
1A9J4		CONTACT, ELEC: same as 1A9J1	5-81
1A9J5		CONTACT, ELEC: same as 1A9J1	5-81
1A9J6		NOT USED	
1A9J7		CONNECTOR: mfr 71468 part no DEF9SC7A101	5-81
1A9J8		CONNECTOR: mfr 71468 part no DBMF13W3SIC27	5-81
		CONNECTOR: mfr 71468 part no DAF15S7A101	5-81
		CONNECTOR: same as 1A9J5	5-81

ORIGINAL

TABLE 6-2. (Continued)

## RECEIVER AND TRANSMITTER SUBASSEMBLY

REF DESIG	NOTES	NAME AND DESCRIPTION	FIG NO
1A9J9		CONNECTOR: 71468 part no DAMF11W1S1C27	5-81
1A9J10		CONNECTOR: same as 1A9J5	5-81
1A9J11		CONNECTOR: same as 1A9J9	5-81
1A9J12		CONNECTOR: mfr 71468 part no DBMF21W151C27	5-81
1A9J13		CONNECTOR: MIL-C-10544 type U79U	5-83
1A9J14		CONNECTOR: mfr 77820 part no 371-7038-010	5-83
1A9J15		CONNECTOR: mfr 98291 part no 3012	5-83
1A9J16		CONNECTOR: mfr 94375 part no RF0752	5-83
1A9J17		CONNECTOR: same as 1A9J15	5-83
thru			
1A9J21			
1A9J22		NOT USED	
1A9J23		NOT USED	
1A9J24		ADAPTER: mfr 94375 part no RF02105	5-81
1A9J25		JACK, TIP: WHT; mfr 98291 part no SKT10WHITE	5-81
1A9J26		CONNECTOR-mfr 98278 part no 053-0577	5-81
1A9K1		RELAY mfr 01526 part no 3SAE2049A2	5-81
1A9K2		NOT USED	
1A9K3		RELAY: same as 1A9K1	5-81
1A9K4		RELAY: same as 1A9K1	5-81
1A9K5		NOT USED	
1A9K6		RELAY mfr 09026 part no BR7X300D2S3-26V	5-84
1A9L1		REACTOR: mfr 07388 part no 12532B	5-81
1A9L3		NOT USED	
1A9L4		COIL, RF: MIL type LT4K032	5-83
1A9L5		COIL, RF: MIL type LT4K030	5-83
1A9L6		SOLENOID: mfr 81840 part no A38992-001	5-83
1A9L7		SOLENOID: same as 1A9L6	5-83
1A9MP1		CHASSIS, RECEIVER-TRANSMITTER: al, 0.697 in by 3.656 in by 10.250 in o/a dim, mfr 13499 part no 548-7403-005	5-81
1A9MP2		FILTER BOX: brs, 0.781 in by 1.125 in 2.062 in o/a dim, mfr 13499 part no 548-7519-003	5-81
1A9MP3		CHASSIS, ELEC EQPT: al, 3 015 in by 3.656 in by 11 187 in o/a dim, mfr 13499 part no 548-7233-005	5-81
1A9MP4		CHASSIS, ELEC EQPT: al, 2.937 in by 3.656 in by 11 187 in o/a dim, mfr 13499 part no 548-7235-005	5-81
1A9MP5		BASE, XSTR: al, 11/16-24 ext thd, 0.265 in lg, 0.391 in lg o/a; mfr 13499 part no 548-7002-002	5-81
1A9MP6		CAP, XSTR: al, 11/16-24 nit thd, 3/4 in dia by 7/16 in lg, mfr 13499 part no 548-7003-002	5-81
1A9MP7		NOT USED	
1A9MP8		SPACER. SLV: al, chromate dipped, 0.152 in ID, 0.250 in OD, 0.250 in g, mfr 13499 part no 541-6021-002	5-81
1A9MP9		NUT, PL, HEX: al, 4-40 thd, 0.250 in hex 0.250 in lg, mfr 13499 part no 540-9160-003	5-81
1A94P10		SHAFT, SWITCH: 0.324 in by 0.703 in by 1 281 in o/a dim, mfr 13499 part no 548-7539-002	5-81
1A9MP11		COVER, SWITCH: al, chromate dip 0.063 in thk, 1.206 in by 1 518 in mfr 13499 part no 548-7347-002	5-83

ORIGINAL

**TABLE 6-2. (Continued)**

RECEIVER AND TRANSMITTER SUBASSEMBLY

REF DESIG	NOTE S	NAME AND DESCRIPTION	FIG NO
1A9MP12		BLOCK, ELEC EQPT: sil pl finish; 0.971 in by 1.264 in by 1 908 in mfr 13499 part no 548-7353-004	5-83
1A9MP13		BLOCK, ELEC EQPT. brz, incl 4 terminals 0.905 in by 1.264 in by 1 908 in o/a dim, excl terminals, mfr 13499 part no 548-7536-003	5-83
1A9MP14		SPRING, SWITCH cop, 0.163 in by 0.218 in by 0.915 in o/a dim, mfr 13499 part no 548-7542-003	5-83
1A9MP15		SPRING, CLIP beryllium cop, sil pl; 0.253 in by 0.260 in by 0.412 in mfr 13499 part no 548-7540-002	5-83
1A9MP16		SPACER, SLV. al, chromate dip; 0.058 in wall 0.250 in OD, 0.428 in lg; mfr 13499 part no 548-7349-002	5-83
1A9MP17 thru 1A9MP19		NOT USED	
1A9MP20		COVER mfr 95712 part no 583-3	5-83
1A9MP21		BEARING. mfr 13499 part no 309-1795-00	5-81
1A9MP22		BEARING: mfr 43334 part no 77NM1220ZD5J	5-81
1A9MP23		BEARING mfr 96881 part no 3L3F	5-81
1A9MP24		RING: mfr 79136 part no X5133-18MD	5-81
1A9MP25		NOT USED	
1A9MP26		RING mfr 79136 part no 5555-18MD	5-81
1A9MP27		POST, PIVOT, THREADED: CRES, passivate finish; 0.3125 in hex; 0.1868 in dia, 0.578 in lg, mfr 13499 part no 548-7388-002	5-81
1A9MP28		BRACKET, SOCKET: al, chromate dip; 0.900 in thk, 1.047 in dia, 2 4375 in lg, mfr 13499 part no 548-7391-002	5-81
1A9MP29		PAWL: CRES, 0.250 in by 0.375 in by 1.842 in o/a dim, mfr 13499 part no 548-7393-003	5-81
1A9MP30		CABINET, ELEC, EQPT: 9.718 in by 13.983 in by 21.625 in mfr 13499 part no 548-9396-004	5-81
1A9MP31		HANDLE, BOW: al; 0.937 in by 2.750 in by 4.656 in o/a dim, mfr 13499 part no 548-7441-003	5-81
1A9MP32		CLAMP, WINDOW: al, chemical film finish, 0.100 in by 0.437 in by 1 718 in mfr 13499 part no 548-7978-004	5-81
1A9MP33		GUARD, PANEL: CRES, blacken, 0.250 in dia, 6.446 in lg, mfr 13499 part no 548-7450-002	5-81
1A9MP34		GEARSHAFT, SPUR: delrin, 0.790 in dia by 1.875 in lg o/a dim, mfr 13499 part no 548-7453-002	5-81
1A9MP35		GEAR, SPUR: CRES, 1.428 in dia by 0.125 in thk o/a dim, mfr 13499 part no 543-7462-002	5-81
1A9MP36		GEAR, SPUR: al, 1.541 in dia by 0.375 in lg o/a dim, mfr 13499 part no 548-7455-002	5-81
1A9MP37		GEAR, SPUR: delrin, 1.291 in dia by 0.375 in lg o/a dim, mfr 13499 part no 548-7457-002	5-81
1A9MP38		GEAR, SPUR: CRES, 0.458 in dia by 0.375 in lg o/a dim; mfr 13499 part no 548-7458-002	5-81
1A9MP39		GEAR, SPUR: CRES; 1 428 in dia by 0.125 in thk o/a dim, mfr 13499 part no 548-7452-002	5-81
1A9MP40		GEARSHAFT, SPUR: CRES, 0.291 in dia by 2.562 in lg o/a dim, mfr 13499 part no 548-7463-002	5-81
1A9MP41		GEARSHAFT, SPUR: delrin, 0.291 in dia by 2.312 in lg o/a dim, mfr 13499 part no 548-7464-002	5-81

ORIGINAL

TABLE 6-2. (Continued)

## RECEIVER AND TRANSMITTER SUBASSEMBLY

REF DESIG	NOTES	NAME AND DESCRIPTION	FIG NO
1A9MP42		SHAFT, STR, SPECTRUM: CRES, passivate finish, 0.1872 in dia, 2.125 in lg, mfr 13499 part no 548-7460-002	5-81
1A9MP43		NOT USED	
1A9MP44		GEAR, SPUR, IDLER, NO 3; al, anodize finish, 0.275 in by 0.500 in mfr 13499 part no 548-7477-002	5-81
1A9MP45		SPACER, SLV: al, chemical film finish, 0.250 in OD by 0.187 in lg, mfr 13499 part no 541-6019-002	5-81
1A9MP46		NOT USED	
1A9MP47		GEARSHAFT, SPUR: delrin, 1.291 in 1.875 in lg o/a dim, mfr 13499 part no 548-7521-003	5-81
1A9MP48		CLAMP, COUPLER: SST, passivate finish 0.187 in w, 0.562 in dia, mfr 13499 part no 548-7478-002	5-81
1A9MP49		COUPLING HALF, SHAFT: CRES, 0.937 in dia by 0.353 in lg o/a dim, mfr 13499 part no 548-7522-003	5-81
1A9MP50		COUPLING HALF, SHAFT: CRES, 0.937 in dia by 0.328 in lg o/a dim, mfr 13499 part no 548-7523-003	5-81
1A9MP51		COUPLING HALF, SHAFT: CRES, 0.937 in dia by 0.303 in lg o/a dim, mfr 13499 part no 548-7524-003	5-81
1A9MP52		PANEL, FRONT: al 4.440 in by 4.552 in by 11.352 in mfr 13499 part no 548-7442-006	5-81
1A9MP53		HOUSING, GEAR: al, 3.525 in by 3.656 in by 8.431 in o/a dim, mfr 13499 part no 548-7445-005	5-81
1A9MP54		SHAFT, STRAIGHT-DIAL, CONTROL: CRES, passivate finish, 0.1238 in dia, 3.594 in lg; mfr 13499 part no 548-7486-002	5-81
1A9MP55		SHAFT, STR, NO 4: CRES, passivate finish, 0.1872 in dia, 3.594 in lg, mfr 13499 part no 548-7487-002	5-81
1A9MP56		GEAR, SPUR: al; 0.583 in dia by 0.312 in lg o/a dim, mfr 13499 part no 548-7489-002	5-81
1A9MP57		GEAR, HELICAL: al, 0.906 in dia by 0.312 in lg o/a dim, mfr 13499 part no 548-7491-002	5-81
1A9MP58		GEAR, HELICAL: al, 1.484 in dia by 0.312 in lg o/a dim, mfr 13499 part no 548-7492-002	5-81
1A9MP59		GEAR, BEVEL: CRES, 0.562 in dia by 0.375 in lg o/a dim, mfr 13499 part no 548-7503-002	5-81
1A9MP60		GEAR, BEVEL: CRES, 0.562 in dia by 0.375 in lg o/a dim, mfr 13499 part no 548-7505-002	5-81
1A9MP61		GEAR, BEVEL: NO 3.CRES, passivate finish, 16 teeth, 20° pressure angle, 32 diametral pitch; 0.187 in ID, 0.594 in OD, 0.375 in lg, mfr 13499 part no 548-7504-002	5-81
1A9MP62		DIAL ASSY: 1.437 in dia by 1.562 in lg o/a dim, mfr 13499 part no 548-7507-002	5-81
1A9MP63		DIAL ASSY: 1.437 in dia by 0.421 in lg o/a dim, mfr 13499 part no 548-7508-002	5-81
1A9MP64		DIAL ASSY: 1.437 in dia by 1.264 in lg o/a dim, mfr 13499 part no 548-7509-002	5-81
1A9MP65		GEAR CLUSTER, BEVEL-SPUR: two complements of 16 and 36 teeth, 0.790 in dia by 0.468 in lg o/a dim, mfr 13499 part no 548-7510-002	5-81
1A9MP66		SHAFT, STR DIAL: CRES, passivate finish 0.1872 in dia, 5.031 in lg, mfr 13499 part no 548-7511-002	5-81

ORIGINAL

**TABLE 6-2. (Continued)**

RECEIVER AND TRANSMITTER SUBASSEMBLY

REF DESIG	NOTE S	NAME AND DESCRIPTION	FIG NO
1A9MP67		SHAFT, STR, DIAL, CONTROL, TENTHS: CRES, passivate finish; 0.1872 in dia, 3.453 in lg; mfr 13499 part no 548-7501-002	5-81
1A9MP68		SHAFT, STR, DIAL, CONTROL, TENTHS: CRES, passivate finish; 0.1872 in dia, 4.094 in lg; mfr 13499 part no 548-7500-002	5-81
1A9MP69		GEAR, SPUR, COUNTER, NO 7: al, anodize finish; 5/16 in by 13/32 m; mfr 13499 part no 548-7495-002	5-81
1A9MP70		GEAR, SPUR, COUNTER, NO 2: al, anodize finish; 39 teeth, 20° pressure angle, 48 diametral pitch; 5/16 in by 13/32 in mfr 13499 part no 548-7490-002	5-81
1A9MP71		SPIDER: mfr 13499 part no 990-0511-00	5-81
1A9MP72		SPIDER: mfr 13499 part no 990-0512-00	5-81
1A9MP73		SHAFT, STR, DIAL, CONTROL, UNITS: CRES, passivate finish; 0.1872 in dia, 3.0781 in lg, mfr 13499 part no 548-7502-002	5-81
1A9MP74		STUD, EXTENSION: al; 0.312 in w across flats by 0.824 in lg o/a dim; mfr 13499 part no 548-7469-002	5-81
1A9MP75		SHAFT, STR, INPUT: CRES, passivate finish; 0.1872 in dia, 1 1875 in lg; mfr 13499 part no 548-7471-002	5-81
1A9MP76		BUTTON, CABLE: plstc; 4-40NC-2B int thd, 0.187 in lg by 0.250 in hex, mfr 13499 part no 541-5177-002	5-81
1A9MP77		SPRING, HELICAL, EXTENSION: stl; 0.187 in dia by 0.781 in lg o/a dim mfr 13499 part no 340-1018-00	5-81
1A9MP78		NOT USED	
1A9MP79		NOT USED	
1A9MP80		COLLAR, STOP: al, chromate dip, 0.156 in by 0.426 in by 0.618 in 0.187 in dia bore; mfr 13499 part no 548-7480-002	5-81
1A9MP81		COLLAR, STOP: al, 0.226 in by 0.426 in by 0.618 in 0.187 in dia bore; mfr 13499 part no 548-7526-003	5-81
1A9MP82		SHAFT, STR, SPUR GEAR: CRES, passivate 0.1872 in dia, 1 766 m lg, mfr 13499 part no 548-7488-002	5-81
1A9MP83		GEAR, SPUR: al, anodize finish, 48 teeth, 20° pressure angle, 48 diametral pitch; 3/8 in by 13/32 in; mfr 13499 part no 548-7479-002	5-81
1A9MP84		SHAFT, STR: CRES, passivate finish; 0.1872 in dia, 2.573 in lg; mfr 13499 part no 548-7459-002	5-81
1A9MP85		GEAR, SPUR: al, anodize finish, 60 teeth, 20° pres angle, 48 diametral pitch, 3/8 in by 13/32 in mfr 13499 part no 548-7456-002	5-81
1A9MP86		SHAFT, STR, SPECTRUM IDLER: CRES, passivate finish; 0.1872 in dia, 1.875 in lg; mfr 13499 part no 548-7461-002	5-81
1A9MP87		GEAR, SPUR, INPUT: CRES, passivate finish, 40 teeth, 20° pres angle, 48 diametral pitch; 3/8 in by 13/32 in mfr 13499 part no 548-7472-002	5-81
1A9MP88		WINDOW, DIAL: clear plstc; 0.060 in thk; 1.312 in by 1.719 in by 1.844 in mfr 13499 part no 548-7514-003	5-81
1A9MP89		BUSHING, SLY, GEARSHAFT: ph brz, chemical polish; 0.8760 in ID, 1.000 in OD, 0.375 in lg, mfr 13499 part no 548-7397-002	5-81
1A9MP90		SPRING, HELICAL, COMPRESSION: CRES, passivate finish; 0.0220 in by 0.171 in by 0.406 in mfr 13499 part no 544-7906-002	5-81

ORIGINAL



TABLE 6-2. (Continued)

## RECEIVER AND TRANSMITTER SUBASSEMBLY

REF DESIG	NOTES	NAME AND DESCRIPTION	FIG NO
1A9MP91		BALL: mfr 43334 part no 3-16A1BWBALL	5-81
1A9MP92		BRACKET, STAR WHEEL: al, chemical film finish; 0.125 in by 1.156 in by 1.390 in, mfr 13499 part no 544-6940-003	5-81
1A9MP93		RETAINER, SPR: al, anodized finish; 0.296 in by 0.359 in by 0.654 in; mfr 13499 part no 544-7864-002	5-81
1A9MP94		STAR WHEEL: CRES, passivate finish; 0.281 in by 0.406 in by 1.093 in, mfr 13499 part no 554-6939-003	5-81
1A9MP95		GASKET: MIL type AN6227-3	5-81
1A9MP96		COVER: mfr 13499 part no 372-2179-00	5-81
1A9MP97		COVER, ELEC CONN: same as 1A9MP96	5-81
1A9MP98		COLLAR, SHAFT: al, chemical film finish, 0.190 in by 0.234 in by 0.375 in; mfr 13499 part no 548-7832-00	5-81
1A9MP99		BEARING, mfr 43334 part no 77NM1020Z05J	5-81
1A901		KNOB, VOLUME al, blk anodize; 0.609 in ID, 0.750 in OD, 0.875 in lg; mfr 13499 part no 548-7389-002	5-81
1A902		KNOB-SQUELCH: al, blk anodize, 0.468 in ID, 0.531 O.563 in lg, mfr 13499 part no 548-7390-002	5-81
1A903		KNOB: al, anodized finish; 0.750 in dia by 0.875 in lg; mfr 13499 part no 554-6973-003	5-81
1A904		KNOB: setscrew type, al body, 1.125 in dia by 0.750 in lg o/a dim: mfr 13499 part no 549-6077-002	5-81
1A905		KNOB: same as 1A904	5-81
1A906		KNOB: same as 1A904	5-81
1A9P1		NOT USED	
1A9P2		NOT USED	
1A9P3		CONNECTOR: mfr 98291 part no UG1461/U	5-83
1A9P4		CONNECTOR: same as 1A9P3	5-83
1A9P5		CONNECTOR: same as 1A9P3	5-83
1A9P6		CONNECTOR :mfr 94375 part no RF-0721-50	5-83
1A9P7		NOT USED	
1A9P8		CONNECTOR: same as 1A9P6	
1A9P9		CONNECTOR: same as 1A9P3	5-53
1A9P10		CONNECTOR: same as 1A9P6	5-53
1A9Q1		TRANSISTOR: MIL-S-19500/180(SIGC) type 2N1486	5-54
1A9R1		RESISTOR, FXD, WW: MIL-R-26 type RW69V101	5-81
1A9R2		RESISTOR, FXD, WW: 0.50 ohms $\pm$ 1%, 2 5W, mfr 91637 part no RSM2COR500F	5-81
1A9R3		RESISTOR, FXD, WW: MIL-R-26 type RW30V250	5-81
1A9R4		RESISTOR, VAR, CMPSN: MIL-R-94B type RV5NAYSD103D	5-54
1A9R5		RESISTOR, VAR, CMPSN: 50K, $\pm$ 20%, 1/2W; mfr 13499 part no 380-6952-00	5-54
1A9R6		RESISTOR, FXD, WW: same as 1A9R3	5-81
1A9R7		RESISTOR, FXD, CMPSN: MIL:-R-11 type RC20GF391K	5-83
1A9R8		RESISTOR, FXD, CMPSN: MIL:-R-11 type RC07GF474K	5-83
1A9R9		RESISTOR, FXD, WW same as 1A9R1	5-80
1A9R10		RESISTOR, FXD, CMPSN: MIL type RC07GF151K	5-83
1APR11		RESISTOR, FXD, FILM MIL-R-10509 type RN55D2612F	5-82
1A9R12		RESISTOR, FXD, CMPSN: MIL-C-5 type RC07GF103K	5-82
1A9R13		RESISTOR, FXD, FILM: MIL-R-10509 type RN55D6812F	5-82

ORIGINAL

**TABLE 6-2. (Continued)**

RECEIVER AND TRANSMITTER SUBASSEMBLY

REF DESIG	NOTES	NAME AND DESCRIPTION	FIG NO
1A9R14		RESISTOR, FXD, FILM: same as 1A9R11	5-82
1A9R15		RESISTOR, FED, FILM: same as 1A9R13	5-82
1A9S1		SWITCH, RF, XMSN LINE: 6 coupling positions, 59 ohms impedance characteristic, 26.5 Vdc, 2 in by 2-1/4 in by 3 in; mfr 13499 part no 548-7537-005	5-83
1A9S1A		SWITCH SECTION: mfr 13499 part no 269-2273-00	5-83
1A9S1B		SWITCH SECTION: mfr 13499 part no 269-2274-00	5-83
1A9S2		NOT USED	
1A9S3		SWITCH- mfr 76854 part no 211576F1C	5-54
1A9TB1		TERMINAL BOARD. Incl five solder stud terminals; 0.032 in by 1.116 in by 1.428 in board dim; mfr 13499 part no 548-7687-003	5-83
1A9XDS1		LIGHT mfr 08817 part no 855878	5-81
1A9XDS2		LIGHT: same as 1A9XDS1	5-81
1A9XF1		FUSEHOLDER mfr 71400 part no HKPEHLQRWZ	5-81
1A9XF2		FUSEHOLDER. same as 1A9XF1	5-81

RECEIVER-TRANSMITTER CASE CY-3884/PRC-41

1A10		CASE, RECEIVER - TRANSMITTER:al, enamel finish; 4 in by 10.750 in by 12.875 in o/a; mfr 13499 part no 522-3257-036	5-37
1A10H1		SCREW, MACH SST, passivate finish; slotted pan hd; 10-32 NF-2A part no 548-7362-002 trd, 3/4 11A9R14 lg; mfr 13499 part no 548-7362-002	5-55
1A10H2		SCREW, MACH SST, passivate finish; 6-32 NC-2A tied, 7/16 in lg; mfr 13499 part no 549-6246-002	5-55
1A10H3		NUT STRIP CRES, passivate finish; 3/8 in by 11/16 in, mfr 13499 part no 553-9663-002	5-55
1A10J1		CONNECTOR, RCPT, ELEC: 1 sil male cont; 0.452 in w across flats by 0.781 in lg excl cont, mfr 13499 part no 548-7367-003	5-55
1A10J2		CONNECTOR, RCPT, ELEC: same as 1A10J1	5-55
1A10J3		CONNECTOR, RCPT, ELEC: same as 1A10J1	5-55
1A10MP 1		3/16 in dia, mfr 13499 part no 018-1291-00	5-55
1A10MP 2		CASE, RECEIVER-TRANSMITTER: al, 4.420 in by 11.170 in by 12.171 in o/a dim; mfr 13499 part no 548-7223-005	5-55
1A10MP 3		PLATE, RETAINING, ELEC CONN: 0.718 in by 3.125 in by 10 in o/a dim, mfr 13499 part no 548-7369-004	5-55
1A10MP 4		SEAL, RBR, RND SECT: silicon RBR, 0.240 in ID, 0.450 in OD, 0.405 in lg; mfr 13499 part no 548-7363-002	5-55
1A10MP 5		PIN, LOCATING: CRES, passivate finish; 0.563 in hex, 0.422 in dia, 0.791 in lg, mfr 13499 part no 548-7368-003	5-55
1A10MP 6		STRIKE, CATCH: stl; 0.187 in by 0.562 in by 0.625 in o/a dim; mfr 13499 part no 549-6247-002	5-55
1A10MP 7		GASKET: MIL-P-5516 type AN6227-7	5-55

STORAGE BATTERY BB-451/U

2	NOTE 1	BATTERY, STORAGE: sil zinc, alkaline; 24 volt nominal, 25 amp hour nominal; rechargeable, supplied in a dry charge condition; contained in a watertight fiber case; weight is 14.2 pounds; 7-11/16 in by 11-9/16 in by 4-9/64 in mfr 13499 part no 522-2527-004.	5-35
---	--------	--	------

**TABLE 6-2. (Continued)**

POWER SUPPLY PP-3700/PRC-41

REF DESI G	NOTE S	NAME AND DESCRIPTION	FIG NO
3		POWER SUPPLY: 26.5 Vdc, 4 amp output, 115 to 230 Vac, 50 to 400 Hz single; 4-3/16 in w by 7-3/4 in h by 12-1/8 in lg, mfr 13499 part no 522-2528-005	5-36
3C1		CAPACITOR, FXD, ELCTLT: 660UF, M15%P75%, 50V, mfr 06001 part no 29F3273	5-61
3C2		CAPACITOR, FXD, ELCTLT: 33UF, ±20%, 35V; mfr 56289	5-57
3C3		part no 150D336X0035S2	
3C4		CAPACITOR, FXD, ELCTLT: same as 3C2	5-57
		CAPACITOR, FXD, ELCTLT: 47UF, ±20%, 35V, mfr 56289	5-57
3C5		part no 150D476X0035S2	
		CAPACITOR, FXD, ELCTLT: 100UF, ±20%, 20V, mfr 56289	5-57
3C6		part no 150D107X0020S2	
3C7		CAPACITOR, FXD, ELCTLT: same as 3C5	5-57
3C8		CAPACITOR, FXD, ELCTLT: same as 3C2	5-57
3C9		CAPACITOR, FXD, ELCTLT: same as 3C4	5-57
3C10		CAPACITOR, FXD, PPR DIELECT. 0.1UF, ±20%, 400V, mfr 00656 part no 931-4552-00	5-57
3CR1		SEMICOND DEVICE: MIL-S-19500/134(SIGC) type 1N249B	5-57
3CR2		SEMICOND DEVICE: same as 3CR1	5-57
3CR3		SEMICOND DEVICE: same as 3CR1	5-57
3CR4		SEMICOND DEVICE: same as 3CR1	5-57
3CR5		SEMICOND DEVICE: MIL-E-1/1143 type 1N647	5-51
3CR6		SEMICOND DEVICE: same as 3CR5	5-57
3CR7		SEMICOND DEVICE: MIL-S-19500/124(SIGC) type 1N2990B	5-57
3CR8		SEMICOND DEVICE.: MIL-S-19500/117(NAVY) type 1N965B	5-57
3CR9		SEMICOND DEVICE: same as 3CR5	5-57
3E1		CLIP: mfr 71400 part no 4548	5-59
3E2		CLIP, ELEC same as 3E1	5-59
3E3		CONTACT, ELEC: sil, 0.187 in dia by 13/16 in lg, mfr 13499	5-59
3E4		part no 549-1692-002, p/o 3P1, 3P2, 3P3	
		CONTACT, ELEC: coin sil, gold pl finish, 0.187 in dia by 1 in lg, mfr 13499 part no 756-3162-003; Effective on MCN no 2013E4 TERMINAL, LUG: brs; 0.515 in dia mtg hole, accomodates 0.125 in dia condct, mfr 13499 part no 548-7547-002	5-59
3F1		FUSE: MIL type F02A250V 1- 1- 2AS	5-57
3F2		FUSE: same as 3F1	5-57
3H1		SCREW, MACH MODIFIED, NO 1: SST, passivate finish; sltd pan hd, 10-32 NF-2A tied, 0.750 in lg, mfr 13499 part no 548-7362-002	5-59
3H2		RING: mfr 91314 part no 340-0643-00	5-59
3H3		NUT, PL, HEX: CRES; passivate 5/8-18 UNF-2B tied, 0.688 in w across flgts, 0.125 in thk, mfr 13499 part no 548-7419-002H4	5-59
3H4		WASHER: glgss cloth, silicone rbr, 0.086 in ID, 0.750 in OD,	5-57
		0.0050 in thk, mfr 13499 part no 547-2288-003	
3H5		WASHER: glgss cloth, silicone rbr coated, 0.500 in ID, 1.375 in OD, 0.0050 in thk, mfr 13499 part no 553-5038-003	5-58
3H6		WASHER: al; 0.515 in ID, 1.250 in OD, 0.125 in thk, mfr 13499 part no 553-5039-003	5-58

**TABLE 6-2. (Continued)**

POWER SUPPLY PP-3700/PRC-41

REF DESIG	NOTES	NAME AND DESCRIPTION	FIG NO
3H7		WASHER plstc; 0.510 in ID, 0.672 in OD, 0.125 in thk, mfr 13499 part no 553-5041-003	5-58
3J1		CONNECTOR: MIL-C-5015 type MS3102R16S1P	5-57
3J2		CONNECTOR: MIL-C-5015 type MS3102R14S7S	5-57
3K1		RELAY: mfr 09026 part no BR7X300D2S3-26V	5-57
3L1		REACTOR: mfr 98055 part no TS3722	5-57
3MP1		CHASSIS, ELEC EQPT: al; 3.592 in by 5 in by 8-3/16 in; mfr 13499 part no 548-7551-005	5-57
3MP2		CASE, PWR SUPPLY: al; 3.940 in by 7-13/32 in by 11.050 in; mfr 13499 part no 548-7424-004	5-57
3MP3		COVER, PWR SUPPLY: al; 0.624 in by 4.156 in by 10.937 in o/a; mfr 13499 part no 548-7422-004	5-57
3MP3		COVER, PWR SUPPLY: al, chromate dip finish; 0.625 in by 4.156 in by 10.937 in; mfr 13499 part no 548-7423-004	5-57
3MP4		SHELL, ELEC CONN: plstc; 0.750 in dia by 47/64 in lg; mfr 13499 part no 548-7420-003; p/o 3P1, 3P2 and 3P3	5-59
3MP5		RING mfr 79136 part no 5133-9C	
3MP6		SPACER, SLV, NM: neoprene rbr; 0.406 in dia 0.437 in lg, mfr 13499 part no 548-7238-002; p/o 3P1, 3P2, and 3P3	5-59
3MP6		SEAL, CONT 0.423 in dia by 0.393 in lg; mfr 13499 part no 756-3161-002; Effective on MCN 201	5-59
3MP7		DUST CAP: mfr 02660 part no 9760-16-291	5-57
3MP8		CAP: mfr 02660 part no 9760-14-291	5-57
3MP9		RETAINER, CAPACITOR al, 0.719 in by 0.750 in by 2-3/32 in mfr 13499 part no 548-7418-002	5-61
3MP10		GROMMET: mfr 75543 part no 911	5-59
3MP11		GROMMET: mfr 75543 part no 901	5-57
3MP12		HOLDER: mfr 13499 part no 352-9970-00	5-57
3MP13		BASE, XSTR: al; 11/16-24 ext thd, 0.625 in dia 25/64 in lg o/a; mfr 13499 part no 548-7002-002	5-58
3MP14		CAP, XSTR al; 11/16-24 int thd; 3/4 in dia by 7/16 in lg, mfr 13499 part no 548-7003-002	5-58
3MP15		INSULATOR, BSHG: plstc, 5/16 in dia by 0.150 in lg, 0.177 in ID undercut to 0.096 in mfr 13499 part no 548-7004-002	5-58
3MP16		NOT USED	
3P1		CONNECTOR: c/o 3E3 and 3MP4, 3MP5 and 3MP6	5-59
3P2		CONNECTOR: same as 3P1	5-57
3P3		CONNECTOR: same as 3P1	5-59
3Q1		TRANSISTOR MIL-S-19500/182(NAVY) type 2N1893	5-57
3Q2		TRANSISTOR: MIL-S-19500/80A(SIGC) type 3N35	5-58
3Q3		TRANSISTOR: mfr 07688 part no 2N2110	5-58
3Q4		TRANSISTOR: JAN type JAN2N1613	5-57
3R1		RESISTOR, FXD, WW: MIL-R-26 type RW67V471	5-60
3R2		RESISTOR, FXD, WW: MIL-R-26 type RW69V150	5-57
3R3		RESISTOR, FXD, WW: . same as 3R2	5-57
3R4		RESISTOR, EXD, CMPSN: MIL-R-11 type RC32GF331K	5-57
3R5		RESISTOR, FXD, CMPSN: MIL-R-11 type RC32GF821K	5-57
3R6		RESISTOR, VAR, CMPSN: MIL-R-94B type RV5LAYS102B	5-57

TABLE 6-2. (Continued)

## POWER SUPPLY PP-3700/PRC-41

REF DESIG	NOTES	NAME AND DESCRIPTION	FIG NO
3R7		RESISTOR, FXD, CMPSN: MIL-R-11 type RC20GF332K	5-61
3R8		RESISTOR, FXD, CMPSN: MIL-R-11 type RC32GF562K	5-57
3R9		RESISTOR, FXD, CMPSN: MIL-R-11 type RC20GF333K	5-57
3R10		RESISTOR, FXD, CMPSN: MIL-R-11 type RC20GF393K	5-57
3R11		RESISTOR, FXD, CMPSN: MIL-R-11 type RC20GF273K	5-57
3R12		RESISTOR, FXD, CMPSN: MIL-R-11 type RC32GF472K	5-57
3R13		RESISTOR, FXD, WW: MIL-R-26 type RW69V561	5-57
3R14		RESISTOR, THRM: 100K, $\pm 10\%$ , 1W, mfr 10646 part no 763H8	5-57
3R15		RESISTOR, THRM: same as 3R14	5-57
3R16		RESISTOR, FXD, WW: MIL-R-26 type RW69V681	5-60
3R17		RESISTOR, FXD, WW: same as 3R16	5-60
3R18		RESISTOR, FXD, WW: same as 3R16	5-60
3R19		RESISTOR, FXD, CMPSN: MIL-R-11 type RC20GF102K	5-57
3R20		RESISTOR, FXD, CMPSN: MIL-R-11 type RC42GF680K	5-61
3R21		RESISTOR, FXD, CMPSN: same as 3R20	5-61
3R22		RESISTOR, FXD, CMPSN: MIL-R-11 type RC20GF471K	5-57
3R23		RESISTOR, FXD, CMPSN: MIL type RC20GF470K	5-57
3T1		TRANSFORMER: mfr 95088 part no TS3682	5-56
3XF1		FUSEHOLDER: mfr 71400 part no HKPEHLQRWZ	5-58
3XF2		FUSEHOLDER: same as 3XF1	5-58

ORIGINAL

**TABLE 6-2. (Continued)**

DIRECTIONAL ANTENNA AS-1405/PRC-41

REF DESIG	NOTES	NAME AND DESCRIPTION	FIG NO
4		ANTENNA: array, "yagi"; 225 to 400 MHz, movable rotating; mfr 13499 part no 522-2529-005	5-36
4E1		ANTENNA ELEMENT: mfr 13499 part no 548-7313-003; c/o 4MP1, 4MP5, 4MP6, 4MP7 and 4H2	5-62
4E2		ANTENNA ELEMENT: 3/8 in dia by 10.656 in lg, approx, mfr 13499 part no 548-7314-003; c/o 4MP2, 4MP5, 4MP6, 4MP7, and 4H1, 4H2	5-62
4E3		ANTENNA ELEMENT: 3/8 in dia in by 9.468 in lg, approx; mfr 13499 part no 548-7315-003; c/o 4MP3, 4MP5, 4MP6, 4MP7 and 4H1, 4H2	5-62
4E4		ANTENNA ELEMENT: 3/8 in dia by 8.374 in lg, approx; mfr 13499 part no 548-7316-003; c/o 4MP4, 4MP5, 4MP6, 4MP7 and 4H1, 4H2	5-62
4E5		ANTENNA ELEMENT: 0.312 in dia by 7.656 in lg; mfr 13499 part no 548-7308-003; c/o 4MP8, 4MP9	5-62
4E6		ANTENNA ELEMENT: 0.312 in dia by 6.750 in lg; mfr 13499 part no 548-7309-003; c/o 4MP8, 4MP10	5-62
4E7		ANTENNA ELEMENT: 0.312 in dia by 5.875 in lg; mfr 13499 part no 548-7310-003, c/o 4MP11, 4MP12	5-62
4E8		ANTENNA ELEMENT: 0.312 in dia by 5.250 in lg, mfr 13499 part no 548-7311-003; c/o 4MP11, 4MP13	5-62
4E9		ANTENNA ELEMENT: 0.312 in dia by 4.656 in lg; mfr 13499 part no 548-7312-003; c/o 4MP11, 4MP14	5-62
4E10		CONTACT STRIP, ELEC: cop, sil pl; 0.010 in by 2-5/16 in by 29-5/8 in; mfr 13499 part no 548-7307-003	5-62
4H1		NUT, SLV: CRES; 0.375 in dia 0.563 in lg; mfr 13499 part no 548-7289-002	5-62
4H2		PIN, SPR: MS type MS16562-190	5-62
4H3		INSERT, LARGE: brs; 0.625 in dia by 1-1/2 in lg, incl pin; mfr 13499 part no 548-7356-002	5-62
4H4		INSERT, SMALL: brs; 0.562 in dia by 1-1/2 in lg; incl pin; mfr 13499 part no 548-7357-002	5-62
4MP1		ELEMENT SECTION, ANT: brs tube; 0.089 in ID, 0.205 in OD, 7-5/32 in lg; mfr 13499 part no 548-7291-002	5-62
4MP2		ELEMENT SECTION, ANT: brs tube; 0.089 in ID, 0.205 in OD, 5 in lg; mfr 13499 part no 548-7292-002	5-62
4MP3		ELEMENT SECTION, ANT: brs tube, 0.089 in ID, 0.205 in OD, 3-13/16 in lg; mfr 13499 part no 548-7293-002	5-62
4MP4		ELEMENT SECTION, ANT: brs tube; 0.089 in ID, 0.205 in OD, 2-23/32 in lg; mfr 13499 part no 548-7294-002	5-62
4MP5		ELEMENT SECTION, ANT brs tubing; 5/16 in dia by 6-1/8 in lg; mfr 13499 part no 548-7287-002	5-62
4MP6		FERRULE, ELEMENT: brs, chrome pl, 0.270 in dia by 15/64 in lg; mfr 13499 part no 548-7288-002	5-62
4MP7		CAP, ELEC: brs, 0.250 in dia by 1/2 in lg; mfr 13499 part no 548-7290-002	5-62
4MP8		PLUG, ELEMENT: brass; 0.312 in dia by 0.250 in lg; mfr 13499 part no 548-7300-002	5-62
4MP9		ELEMENT SECTION, ANTENNA: brs tubing;; 0.248 in ID, 0.312 in OD, 7-17/32 in lg; mfr 13499 part no 548-7295-002	5-62
4MP10		ELEMENT SECTION ANT: brs tubing, 0.248 in ID, 0.312 in OD, 6-5/8 in lg; mfr 13499 part no 548-7296-002	5-62

**TABLE 6-2. (Continued)**

## DIRECTIONAL ANTENNA AS-1405/PRC-41

REF DESIG	NOTES	NAME AND DESCRIPTION	FIG NO
4MP11		PLUG, ELEMENT: brs, 0.250 in dia by 0.250 in lg; mfr 13499 part no 548-7301-002	5-62
4MP12		ELEMENT SECTION, ANT: brs, tubing; 0.186 in ID, 0.250 in OD, 5-7/8 in lg; mfr 13499 part no 548-7297-002	5-62
4MP13		ELEMENT SECTION, ANT: brs tubing; 0.186 in ID, 0.250 in OD, 5-1/8 in lg; mfr 13499 part no 548-7298-002	5-62
4MP14		ELEMENT SECTION, ANTENNA: brs tubing; 0.186 in ID, 0.250 in OD, 4-17/32 in lg, mfr 13499 part no 548-7299-002	5-62
4MP15		NOT USED	
4MP16		SUPPORT, ANT: 1.500 in by 5.781 in by 24.562 lg approx o/a dim, mfr 13499 part no 548-7284-002	5-62
4MP17		COVER, ELEC CONN: mfr 95712 part no 583-3	5-62
4MP18		LINE SECTION, RADIO FREQUENCY TRANSMISSION: brs; 5/32 in by 0.343 lg by 29.749 in mfr 13499 part no 548-7285-002	5-62
4MPI9		BOOM, ANT. 0.875 in by 3.500 in by 30.718 in approx o/a dim; mfr 13499 part no 548-7318-004; c/o 4E10 and 4H3, 4H4 and 4MP15, 4MP16, 4MP17, 4MP18 and 4W1	5-62
4W1		CABLE ASSY, RF: type RG-141A/U coax cable terminated w/ 1 cont; 46-1/2 in lg o/a; mfr 13499 part no 548-7286-002	5-62
		CONNECTOR: MIL-C-71A type UG-1095A/U p/o 4W1	5-62
		CONNECTOR: mfr 13499 part no 357-9994-00, p/o 4W1	5-62

## ANTENNA AS-1404/PRC-41

5		ANTENNA: stud type; 225 to 400 MHz; fixed; mfr 13499 part no 522-2530-003	5-35
---	--	--	------

## MOUNTING MT-2976/PRC-41

6		MOUNTING; al, item attached to mtg by locking jaws in front and conn rcpt at rear; 5-9/16 in h by 11-1/4 lg w by 16-7/32 in lg; mfr 13499 part no 522-2531-005	5-36
6C1		CAPACITOR, FXD, ELCTLT: 1300UF, M10% P100%, 50V mfr 56289 part no D34393	5-64
6C2		CAPACITOR, FXD, ELCTLT: same as 6C1	5-64
6C3		CAPACITOR, FXD, ELCTLT: 1,675 UF, M10% P100%, 50 V; mfr 56289 part no D36741	5-64
6C4		CAPACITOR, FXD, ELCTLT: same as 6C3	5-64
6C5		CAPACITOR, FXD, ELCTLT: same as 6C3	5-64
6C6		CAPACITOR, FXD, PPR DIELECT: 1.0 UF 20%, 100 V; mfr 56289 part no 186P10501S15	5-64
6C7		CAPACITOR, FXD, PPR DIELECT: same as 6C6	5-64
6CR1		SEMICONV DEVICE: MIL-S-19500/134 (SIGC) type 1N249B	5-64
6E1		CONTACT, ELEC: sil; 0.210 in dia by 1.000 in lg o/a dim; mfr 13499 part no 548-7206-002; c/o 6P1, 6P2, and 6P3	5-64

ORIGINAL

**TABLE 6-2. (Continued)**

MOUNTING MT-2976 /PRC-41

REF DESIG	NOTES	NAME AND DESCRIPTION	FIG NO
6H1		NUT, SLV: al; 1.000 in dia by 1.000 in lg o/a dim; mfr 13499 part no 548-7406-002	5-63
6H2		THUMBSCREW: CRES; 0.750 in dia by 3.250 in lg o/a dim; mfr 13499 part no 548-7216-002	5-63
6H3		BUSHING, MACH THD: CRES; 1.000 in w across flgts by 0.375 in lg o/a dim; mfr 13499 part no 548-7209-002	5-64
6H4		BUSHING, MACH THD: CRES; 1.000 in w across flgts by 0.375 in lg o/a dim; mfr 13499 part no 548-7210-002	5-64
6H5		NUT, PL, HEX: CRES, 1.000 in w across flgts by 0.187 in lg o/a dim, mfr 13499 part no 548-7211-002	5-64
6H6		POST, ELEC-MECH EQPT: al, 0.187 in w across flgts by 1.375 in lg o/a dim, mfr 13499 part no 540-9028-003	5-64
6H7		WASHER, FLAT: rd shape; CRES, passivated finish, 0.120 in ID, 0.375 in OD, 0.018 in thk; mfr 13499 part no 504-0730-003	5-64
6H8		RING: mfr 79136 part no 5133-12MD: p/o 6P1, 6P2, and 6P3	5-64
6H9		SPRING: mfr 91314 part no 340-1010-00	5-64
6H10		POST, ELEC-MECH EQPT: al, 6-32 UNC-2B thd, 5/16 in hex, 0.718 in lg; mfr 13499 part no 540-8455-003	5-64
6H11		POST, ELEC-MECH EQPT: al; 6-32 UNC-2B thd, 5/16 in hex, 0.625 in lg; mfr 13499 part no 540-9452-003	5-64
6H12		NUT, CONT: CRES; 1.000 in w across flgts by 0.468 in lg o/a dim; mfr 13499 part no 548-7212-002	5-64
6H13		INSULATOR, BSHG. plstc; 0.500 in w across flgts by 0.625 in lg o/a dim; mfr 13499 part no 548-7207-002, p/o 6P1, 6P2, and 6P3	5-64
6L1		COIL, RF: mfr 13499 part no 240-0021-00	5-64
6MP1		CLAMP, RIM CLENCHING: al; 0.375 in by 0.953 in by 1.062 in o/a dim; mfr 13499 part no 548-7215-002	5-63
6MP2		PIN, CLEVIS: CRES, 0.375 in dia by 0.656 in lg o/a dim, mfr 13499 part no 548-7214-002	5-63
6MP3		STRAP, RETAINING: al; 0.396 in by 1.500 in by 4.404 in o/a dim; mfr 13499 part no 548-7411-003	5-64
6MP4		COVER, FLTR: al; 0.531 in by 4.718 in by 11.480 in o/a dim, mfr 13499 part no 548-7221-004	5-63
6MP5		RETAINER, CAPACITOR: al; 1.312 in by 2.109 in by 4.500 in o/a dim; mfr 13499 part no 548-7410-003	5-64
6MP6		RETAINER, CAPACITOR: al; 1.312 in by 2.109 in by 4.500 in o/a dim, mfr 13499 part no 548-7408-003	5-64
6MP7		TRAY, MOUNT: al bracket CRES tray; 6.187 in by 11.600 in by 14.937 in o/a dim, mfr 13499 part no 548-7218-004	5-63
6MP8		CAP: mfr 02660 part no 9760-14-291	5-63
6P1		ADAPTER, PWR SUPPLY: sil cons, plstc bshg; 0.500 in w across flgts by 1 in lg, mfr 13499 part no 548-7208-002, c/o 6E1 and 6H8 6H9, and 6H13	5-63
6P2		ADAPTER, PWR SUPPLY: same as 6P1	5-63
6P3		ADAPTER, PWR SUPPLY: same as 6P1	5-63
6P4		CONNECTOR, RCPT, ELEC: MIL-C-5015 type MS3102R14S7P	5-64
6R1		RESISTOR, FXD, WW: MIL-R-26 type RW29VR56	5-64
6R2		RESISTOR, FXD, WW: same as 6R1	5-64
6R3		RESISTOR, FXD, WW: same as 6R1	5-64
6R4		RESISTOR, FXD, WW: same as 6R1	5-64



**TABLE 6-2. (Continued)**

BATTERY ADAPTER W-9

REF DESIG	NOTES	NAME AND DESCRIPTION	FIG NO
7		BATTERY ADAPTER, ASSY, ELEC: 27.250 in lg o/a approx;	5-36
7E1		mfr 13499 part no 548-7568-002	5-63
7J1		TERMINAL, LUG: cop, 0.750 in by 0.750 in by 1.750 in;	
7J2		mfr 13499 part no 548-7566-002	
7J3		NOT USED	
		NOT USED	
		CONNECTOR mfr 71468 part no CA3101E14S7SME	5-65

POWER ELECTRIC CABLE ASSEMBLY CX-8687/PRC-41

REF DESIG	NOTES	NAME AND DESCRIPTION	FIG NO
8		CABLE ASSY, PWR, ELECTRIC. 3 conductors, no 16 AWG	5-36
		terminated ea end w cone; 50 ft lg o/a, mfr 13499 part no 522-2533-002	
8P1		CONNECTOR: MIL type MS3106A16S1S	5-66
8P2		CONNECTOR: mfr 74545 part no 7057	5-66

POWER ELECTRIC CABLE ASSEMBLY CX-8686/PRC-41

REF DESIG	NOTES	NAME AND DESCRIPTION	FIG NO
9		CABLE ASSY, PWR, ELECTRIC: 2 conductors no 14 AWG	5-56
		terminated	
		ea end w conn; 20 ft lg o/a; mfr 13499 part no 522-2534-002	
9P1		CONNECTOR: mfr 71468 part no CA06R14S7P	5-66
9P2		CONNECTOR. mfr 71468 part no CA06R14S7S	5-66

RADIO FREQUENCY CABLE ASSEMBLY CG-55G/U

REF DESIG	NOTES	NAME AND DESCRIPTION	FIG NO
10		CABLE ASSY, RF: 50 ohms coax; stranded cop condct, 20 ft lg o/a;	5-36
		terminated each end w/ cone; mfr 13499 part no 522-2535-003	
10P1		CONNECTOR: MIL type MS91236	5-66
10P2		CONNECTOR: same as 10P1	5-66
10MP1		COVER, ELEC, CONN: mfr 95712 part no 9756-1	5-66
10MP2		COVER, ELEC, CONN: same as 10MP1	5-66

SPECIAL PURPOSE ELECTRICAL CABLE ASSEMBLY CX-8688/PRC-41

REF DESIG	NOTES	NAME AND DESCRIPTION	FIG NO
11		CABLE ASSY, SP, ELEC: 10 condct no 26 AWG: terminated ea end	5-36
		w/ conn; 10 ft lg o/a; mfr 13499 part no 522-2536-002	
11P1		CONNECTOR: MIL type MS91481	5-66
11P2		CONNECTOR: same as 11P1	5-66

**TABLE 6-2. (Continued)**

MAST AB-777/PRC-41

REF DESIG	NOTES	NAME AND DESCRIPTION	FIG NO
12		MAST: al; 28.250 in closed max h, 78.250 in when nested, mfr 13499	5-36
12H1		part no 522-2537-004 NUT, SLV, SMALL: CRES, chemically blk; 1.500 in dia 1.625in lg; mfr 13498 part no 548-7277-003	5-67
12H2		NUT, SLV, LARGE: CRES, chemically blk; 1.625 in dia 1.625 in lg; mfr 13499 part no 548-7276-003	5-67
12MP1		CAP, MAST: al alloy grn enamel finish; 2.687 in dia by 2 in lg; mfr 13499 part no 548-7279-00	5-67
12MP2		CAP, TUBE: al; 1.390 in dia by 0.375 in lg; mfr 13499 part no 548-7274-002	5-67
12MP3		SPIKE ASSY, ANT ANCHOR: 0.875 in dia by 7.875 in lg; mfr 13499 part no 548-7266-002; c/o 12MP4, 12MP5, and 12MP6	5-67
12MP4		PIN, SPR: MIL type MS16562-217	
12MP5		SPIKE, ANT ANCHOR: CRES; 0.500 in dia by 7.875 in lg; mfr 13499	5-67
12MP6		part no 548-7264-002 BUSHING, SPIKE: CRES; 0.437 in ID, 0.875 in OD, 1.375 in lg;, 3/4-14 ext thd, 3/8 in lg; mfr 13499 part no 548-7265-002	5-67
12MP7		MAST SECTION: al, 1.250 in dia by 25.625 in lg; mfr 13499 part no 548-7269-003	5-67
12MP8		MAST SECTION: al; 1.225 in ID, 1.375 in OD, 24 in lg; mfr 13499 part no 548-7270-002	5-67
12MP9		WEDGE, SMALL: plstc, 1 219 in ID, 1.333 in OD, 0.500 in lg; mfr 13499 part no 548-7273-002	5-67
12MP10		WEDGE, LARGE: plstc; 1 375inID, 1.489inOD, 0.500 in thk; mfr 13499 part no 548-7272-002	5-67
12MP11		MAST SECTION: al; 1.385 in ID, 1.498inOD, 22.500 in lg; mfr 13499 part no 548-7271-002	5-67
12MP12		PLUG, MAST: CRES; 1.390india by 0.375inlg; mfr 13499 part no 548-7275-002	5-67

ANTENNA MAST ADAPTER

REF DESIG	NOTES	NAME AND DESCRIPTION	FIG NO
13		ADJUSTMENT, ELEVATION: mfr 13499 part no 548-7335-004	5-36
13H1		THUMBSCREW: CRES; 0 750india by 0.219 in h head; 10-32 tied, 0.750 in lg; 1.625 in lg o/a; mfr 13499 part no 548-7332-002	5-68
13H2		WASHER, FLAT: CRES, passivate finish, 0 203 in ID, 0.375 in OD, 0.006 in thk; mfr 13499 part no 547-2314-003	5-68
13MP1		PIN: MIL type MS16562-190	5-68
13MP2		PIN: MIL type MS16562-192	5-68
13MP3		PIN: MIL type MS16562-223	5-68
13MP4		JOINT SECTION, LONG: 1.875 in dia by 6.625 in lg, approx, mfr 13499 part no 548-7324-003	5-68
13MP5		JOINT SECTION, SHORT: 1.875 in dia by 4.062 in lg, approx; mfr 13499 part no 548-7324-002	5-68
13MP6		SHAFT, STR: CRES, 0.312 in dia by 1.375 in lg, 5/16-24 ext thd, 0.750 in lg; mfr 13499 part no 548-7330-002	5-68

**TABLE 6-2. (Continued)**

## ANTENNA MAST ADAPTER

REF DESIG	NOTES	NAME AND DESCRIPTION	FIG NO
13MP7		PIN, STR, HDLS: CRES; 0.312 in dia by 0.484 in lg; mfr 13499 part no 548-7329-002	5-88
13MP8		CLAMP, LOOP: al; accommodates 1-3/4 in dia material, mfr 13499 part no 548-7334-002	5-68
1301		KNOB: cast iron, grn enamel finish; screw on type, star shape; 2 in dia by 0.750 in thk; mfr 13499 part no 548-7331-002	5-68

## MOUNTING MT-2977/PRC-41

14		MOUNTING al; item attached to mtg by two quick release clgmps; 3/8 in h by 5-1/4 in w by 10-3/4 in lg; mfr 13499 part no 522-2539-003	5-36
14MP1		BRACKET, SHELF: . al, chromate dlp; 0.125 in by 0 281 in by 0.812 in mfr 13499 part no 548-7198-002	5-69
14MP2		RING, RETAINING: al, chromate dip; 0.125 in by 2.188 in by 3.563 in mfr 13499 part no 548-7204-004	5-69

## HANDSET H-33E/PT

15		HANDSET: mfr 97101 part no 1212	5-35
----	--	---------------------------------	------

## ELECTRICAL EQUIPMENT HARNESS

16	NOTE 1	ELECTRICAL EQUIPMENT HARNESS: FRAME: mfr 13499 part no 015-1630-010 STRAP: mfr 13499 part no 011-0110-00 STRAP: mfr 13499 part no 021-0190-00 BILLET: mfr 13499 part no 021-0192-00 CARRIER: mfr 13499 part no 021-0253-00 SHOULDER, STRAP ASSY: incl strap support and 2 plates, mfr 13499 part no 548-7583-003 FRAME ASSY: 4.906 in by 7.875 in by 10.686 in mfr 13499 part no 548-7590-003	5-35 5-70 5-70 5-70 5-70 5-70 5-70 5-70
----	--------	--	--

## BRACKET ASSEMBLY

17		BRACKET ASSY, CONN: 1-7/8 in by 4 937 in by 8-5/8 in mfr 13499 part no 548-7413-003	6-36
17H1		NUT, PL, RND: sil pl; 5/8-24; mfr 94375 part no 02105-2	5-71
17J1		ADAPTER: MIL-C-71 type UG30DU	5-71
17MP1		BRACKET: al; 1-7/32 in by 4-3/16 in by 8.625 in; mfr 13499 part no 548-7414-004	5-71

ORIGINAL

**TABLE 6-2. (Continued)**

SPARE A PARTS A KIT

REF DESIG	NOTES	NAME AND DESCRIPTION	FIG NO
18		SPARE PARTS KIT: c/o HOLDER ASSY, TOP, mfr 13499 part no 554-6868-004, HOLDER ASSY, BOTTOM, mfr 13499 part no 554-6867-004, 1 Electron Tube MIL type 7554, 1 Electron Tube MIL type 7077, 1 Electron Tube, MIL type 6442, 2 Lamps, MS type MS25237-328 and 6 Fuses, MIL type F02A250V1 1-2AS	

MAINTENANCE KIT

19		MAINTENANCE ACCESSORY KIT: incl 8 cables, 3 test adapters and 1 bag; mfr 13499 part no 548-7559-00	3-56
19CP1		ADAPTER, TEST: 1-3/8 in by 1-1/2 in by 8-3/16 in; mfr 13499 part no 548-7545-003; c/o 19E1 19H1 19H2, 19H3, 19J1, 19MP1, 19MP2, and 19MP3	5-73
19CP2		ADAPTER: mfr 13499 part no 357-9918-00	5-72
19CP3		ADAPTER: mfr 13499 part no 357-9919-00	5-72
19E1		CONTACT: cop, sil PL; 0.250 in by 0 500 in by 1.753 m; mfr 13499 part no 548-73B1-002, p/o 19CP1	5-73
19H1		SCREW, MACH: MIL type MS35217-55, p/o 19CP1	5-73
19H2		SCREW, MACH: MIL type MS35216-14; p/o 19CP1	5-73
19H3		WASHER, LOCK: MIL type MS35337-78, p/o 19CP1	5-73
19J1		CONNECTOR: MIL-C-5015 type MS3102R14S7P; p/o 19CP1	5-73
19J2		ADAPTER: MIL-C-71 type UG29B/U	5-73
19MP1		CONTACT ASSY, ELEC: 0.625 in by 1.375 in by 8.188 in 3 elec cont; mdt on plstc plgte, mfr 13499 part no 548-7544-003, p/o 19CP1	5-73
19MP2		NUT: al, chromate dipped, open end type, headless, 4-40 NC-2B thd, 0.250 in w across flgts, 0.750 in lg, mfr 13499 part no 540-9176-003, p/o 19CP1	5-73
19MP3		RING: mfr 78189 part no 213-070408-2303; p/o 19CP1	5-73
19W1		CABLE ASSY: stranded no 22 AWG conductors, type RG-178B/U coax cable terminated w/conn ea end, 18 ft lg o/a, mfr 13499 part no 548-7569-003	5-72
19W1J1		CONNECTOR: mfr 71468 part no DBM21W1S	5-72
19W1P1		CONNECTOR: mfr 71468 part no DBM21W1PC27	5-72
19W2		CABLE ASSY: SPG, ELEC: stranded cop conductors no 22 AWG, RG-178 B/U cable terminated ea end w/ connectors; 18 ft lg o/a; mfr 13499 part no 548-7571-003	5-72
19W2J1		CONNECTOR: mfr 71468 part no DBM13W3SC27	5-72
19W2P1		CONNECTOR: mfr 71468 part no DBM13W3PC27	5-72
19W3		CABLE ASSY: SPCL, ELEC: stranded no 22 AWG cndct RG-178B/U cable terminated ea end w/ con; 18 ft lg o/a, mfr 13499 part no 548-7572-003	5-72
19W3J1		CONNECTOR: mfr 71468 part no DAM11W1SC27	5-72
19W3P1		CONNECTOR: mfr 71468 part no DAM11W1PC27	5-72
19W4		CABLE ASSY, SPCL; stranded no 22 AWG cndct terminated ea end w/ connector: 18 ft lg o/a; mfr 13499 part no 548-7573-003	5-72
19W4J1		CONNECTOR: mfr 71468 part no DA15SC7A101	5-72

**TABLE 6-2. (Continued)**

## MAINTENANCE KIT

REF DESIG	NOTES	NAME AND DESCRIPTION	FIG NO
19W4P1		CONNECTOR: mfr 71468 part no DA15PC7	5-72
19W5		CABLE ASSY SPCL ELEC: stranded no 22 AWG conductor terminated ea end w/connector; 18 ft lg o/a; mfr 13499 part no 548-7574-003	5-72
19W5J1		CONNECTOR: mfr 71468 part no DE9PC7	5-72
19W5P1		CONNECTOR: mfr 71468 part no DE9SC7A101	5-72
19W6		CABLE ASSY: mfr 98291 part no 53-0164-061	5-72
19W7		CABLE ASSY mfr 98291 part no 53-0163-061	5-72
19W8		CABLE ASSY, RF; type RG-303/U coax cable, terminated each end w/conn 18 in lg o/a, mfr 13499 part no 548-7570-003	5-72

## TOOL KIT

20		TOOL KIT, ELEC: 12 electronic tools and 1 brush enclosed in cotton duck bag, mfr 13499 part no 548-7538-003 BAG: mfr 13499 part no 024-0351-00 KEY: mfr 70276 part no GT1003 SCREWDRIVER: mfr 65814 part no 62 ALIGNMENT TOOL: mfr 13499 part no 024-0426-00 SCREWDRIVER: mfr 79061 part no P111 KEY: mfr 13499 part no 024-0019-00 KEY: mfr 13499 part no 024-0730-00 KEY: mfr 13499 part no 024-2900-00 KEY: mfr 13499 part no 024-0178-00 SCREWDRIVER: mfr 79061 part no A116-3 WRENCH, SPANNER: CRES; 0.065 in thk, 1.250 in OD, 4 375 in lg; mfr 13499 part no 548-7431-002 BRUSH PAINT: mfr 13499 part no 024-0371-00 ALIGNMENT TOOL, ELECTRONIC EQPT: plstc handle and tip, w/hex on end, mfr 13499 part no 548-9286-002 ALIGNMENT TOOL: mfr 81815 part no 25C104	5-36
----	--	---	------

## GUY ROPE ASSEMBLY

21		GUY ROPE ASSY mfr 13499 part no 012-5103-00	5-36
----	--	---	------

## GUY STAKE

22		STAKE GUY: . CRES, chemically blacken, 1 in by 1 in by 10 in; mfr 13499 part no 548-7338-003	5-36
----	--	---	------

## DIRECTIONAL ANTENNA CASE

23		COVER ASSY ANT: 1.280 in by 19.718 in by 31.531 in o/a dim: mfr 13499 part no 548-7427-004	5-36
23MP1		GROMMET: mfr 83014 part no H322-3-1	5-74
23MP2		PLUNGER: mfr 13499 part no 015-2243-00	5-74
23MP3		COVER, ANT: plstc; 0 781 in by 19 718 in by 31.531 in right cover, mfr 13499 part no 548-7428-005	5-74

ORIGINAL

**TABLE 6-2. (Continued)**

REF DESIG	NOTES	NAME AND DESCRIPTION	FIG NO
23MP4		COVER, ANT: plstc; 0.781 in by 19.718 in by 31.531 in; left cover; mfr 13499 part no 548-7429-005	5-74
23MP5		ROD, HANDLE: al, 0.620 in ID, 0.750 in OD, 5.125 in lg; mfr 13499 part no 548-7426-002	5-74

RADIO SET CASE CY-3883/PRC-41

24		CASE.: mfr 13499 part no 021-0207-00	1-2
----	--	--------------------------------------	-----

ELECTRONIC EQUIPMENT CASE CY-3885/PRC-41

25		CASE.: mfr 13499 part no 021-0208-00	1-3
----	--	--------------------------------------	-----

EQUIPMENT REPAIR PARTS (WHEN ORDERED)

26		EQUIPMENT REPAIR PARTS: c/o the following; ELECTRON TUBE: MIL-E-1 type 7077 (qty 1) ELECTRON TUBE: MIL-E-1 type 7554 (qty 1) ELECTRON TUBE: MIL-E-1C type 6442 (qty 1) LAMP: MIL-L-6363 type MS25237-327 (qty 2) FUSE: MIL-F- 15160 type F02A250V3AS (qty 2) FUSE: mfr 71400 part no MDX1 1-2 (qty 4)	
----	--	---	--

SPECIAL

PURPOSE ELECTRICAL CABLE ASSEMBLY CX-10831/PRC-41A

27		CABLE ASSY, SPCL, ELEC: 2 ft long; mfr 13499 part no 767-1975-001	5-36
27PI		CONNECTOR: MS type MS3116J14-19P	5-84
27P2		CONNECTOR: mfr 77820 part no PT06W16-26S	5-84

**TABLE 6-3 LIST OF MANUFACTURERS**

MFR CODE	NAME AND ADDRESS	MFR CODE	NAME AND ADDRESS
00136	Mc Coy Electronics Co. Watts-Chestnut St. Mt. Holly Springs, PA 17065	10646	Carborundum Co., The P.O. Box 337 Niagara Falls, NY 14302
00656	Aerovox Corp. 740 Belleville Ave. New Bedford, MA 02745	13499	Collins Radio Co. 5225 C Ave. N.E. Cedar Rapids, IA
01121	Allen-Bradley Co. 1201 S. 2nd St Milwaukee, WI 53204	40920	MPB Corp. Precision Park Keene, NH 03431
01526	General Electric Co  Specialty Control Dept P.O. Box 812 Waynesboro, VA 22980	43334	New Departure-Hyatt Bearings Div. General Motors Corp. Hayes Ave. Sandusky, OH 44870
02114	Ferroxcube Corp Mt. Marion Rd Saugerties, NY 12477	56289	Sprague Electric Co. North Adams, MA 01247
02660	Amphenol Corp. 2801 S 25th Ave Broadview, IL 60153	65814	Williams, J. H. and Co. 400 Vulcan St. Buffalo, NY 14207
03877	Transitron Electronic Corp 168-186 Alblon St Wakefield MA 01880	70276	Allen Mfg. Co Box 570
04435	Jettron Products, Inc. P.O. Box 277 Hanover, NJ 07936	70417	Chrysler Corp. Amplex Div.  6501 Harper Ave. Detroit, MI 48211
06001	General Electric Co Electronic Capacitor and  Battery Dept. P.O. Box 158 Irmo, SC 29063	70674	ADC Products Div. of Magnetic Controls Co. 6405 Cambridge St. Minneapolis, MN 55426
07388	Torotel, Inc. 13402 S. 71 Hwy. Grandview, MO 64030	71400	Bussmann Mfg. Div of McGraw-Edison Co. 2536 W. University St. St. Louis, MO 63017
07688	Joint Electron Device Engineering Council Washington, DC 20443	71468	ITT Cannon Electric, Inc 3208 Humbolt St. Los Angeles, CA 90031
08817	Epec Industries, Inc New Bedford Industrial Park New Bedford MA 02745	71590	Globe-Umon, Inc. Centralgb Div P.O. Box 591 Milwaukee, WI 53201
09026	Babcock Electronics Corp Relgys Div.  P.O. Box 1499 Costa Mesa, CA 92626	72136	Electro Motive Mfg. Co Inc., The South Park and John Streets  Willimantic, CT 06226

**TABLE 6-3. LIST OF MANUFACTURERS (Continued )**

MFR CODE	NAME AND ADDRESS	MFR CODE	NAME AND ADDRESS
72982	Erie Technological Products, Inc. 644 W. 12th St. Erie, PA 16512	80294	Bourns, Inc 200 Columbia Ave. Riverside, CA 92507
73386	Freed Transformer Co, Inc 1736 Weirfield St. Brooklyn, NY 11227	81349	Military Specifications Promulgated by Standardization Div. Directorate of Logistic Services DSA
73899	JFD Electronics Corp 15th At 62nd St. Brooklyn, NY 11219	81483	International Rectifier Corp 233 Kansas St. El Segundo, CA 90245
74545	Hubbell, Harvey, Inc State St. and Bostwck Ave Bridgeport, CT 06602	81815	Communication Coil Co. 2839 N. Narragansett Ave. Chicago, IL 60634
75543	Lavelle Rubber Co 424 N. Wood Chicago, IL 60622	81840	Ledex, Inc 123 Webster St Dayton, OH 45402
76854	Oak Mfg Co Div of Oak Electro/Netics Corp S Main Crystal Lake, IL 60014	82142	Airco Speer Electronic Components 4 Hoover Ave. Du Bois, PA 15801
77820	Bendix Corp ,The Electrical Components Div. Sherman Ave Sidney, NY 13838	83014	Hartwell Corp. 9035 Venice Blvd. Los Angeles, CA 90034
78189	Illinois Tool Works, Inc Shakeproof DIV. 91314 St. Charles Rd Elgm, IL 60126	83086	New Hampshire Ball Bearings, Inc. Peterborough, NH 03458
78488	Stackpole Carbon Co. St. Marys, PA 15857	91314	Lewis Spring and Mfg. Co. 2652 W. North Ave. Chicago, IL 60647
79061	Vaco Products Co 510 N. Dearborn 91663 Chicago, IL 60610	91637	Dale Electronics, Inc P O Box 609 Columbus, NB 68601
79136	Waldes Kohinoor, Inc 47-16 Austel Plgce Long Islgnd City, NY	91663	ArmelElectronics, Inc. 1601 75th St. Bergen, NJ 07047
80008	Electro Engineering Works 401 Preda St.  San Leandro, CA 94577	92054	Radio Cores, Inc 5757 W 95th St Oak Lawn, IL 60453
80131	Electromc Industries Assoc 2001 Eye St. in W. Washington DC 20006	93106	Accurate Products Co., Inc. Culver City, CA 90230
		94217	Midlgnd Adhesive and Chemical Corp. 2604 Goodrich Ave. Ferndale, MI 48220



**TABLE 6-3. LIST OF MANUFACTURERS (Continued)**

MFR CODE	NAME AND DESCRIPTION	MFR CODE	NAME AND DESCRIPTION
94375	Automatic Metal Products Corp 315-323 Berry St Brooklyn, NY 11211	97101	Audiosears Corp. South St. Stamford, NY 12167
95088	Transomc, Inc 808 16th St Bakersfield, CA 93301	97137	TRW Electronic Components Div. Chicago, IL 60607
95712	Bendix Corp, The Microwave Devices Div. Hurricane Rd. Franklin, IN 46131	98055	Whaling City Marine Co., Inc 56 Prospect New Bedford, MA 02740
96881	Thomson Industries, Inc 1029 Plgdome Rd Manhasset, NY 11030	98278	Microdot, Inc 220 Pasadena Ave. S. Pasadena, CA 91030
96906	Military Standards Promulgated by Standardization Div. Directorate of Logistic Services DSA	98291	Seaelectro Corp. 225 Hoyt Mamaroneck NY 10544
		99800	Delevan Electronics Corp. 270 Quaker Rd. East Aurora, NY 14052

ORIGINAL

6-53, 6-54

**USER ACTIVITY TECHNICAL MANUAL COMMENT SHEET**  
**NAVSHIPS 4914 (10-62)**  
(COG 1 - 11-DIGIT STOCK NUMBER: 0105-503-9850)

NAVSHIPS NO. \_\_\_\_\_

VOLUME NO. \_\_\_\_\_

*(Fold on dotted. line on reverse side, staple, and mail to NAVSEC)*

---

PROBLEM AREA:

Ship or Station \_\_\_\_\_

Fold

-----  
Department of Navy  
Naval Ship Systems Command  
Washington, D.C. 20360  
OFFICIAL BUSINESS

Postage and Fees Paid  
NAVY DEPARTMENT

Commander, Naval Ship Engineering Center  
Technical Support Branch  
Department of the Navy  
Washington, D.C. 20360

-----  
Fold

RECOMMENDED CHANGES TO EQUIPMENT TECHNICAL PUBLICATIONS

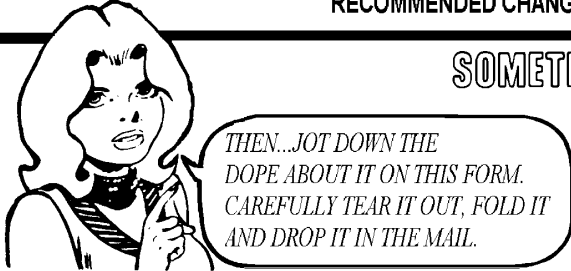
 <p style="text-align: center;"><i>THEN...JOT DOWN THE DOPE ABOUT IT ON THIS FORM. CAREFULLY TEAR IT OUT, FOLD IT AND DROP IT IN THE MAIL.</i></p>		SOMETHING WRONG WITH PUBLICATION		
		FROM: (PRINT YOUR UNIT'S COMPLETE ADDRESS)		
		DATE SENT		
PUBLICATION NUMBER		PUBLICATION DATE	PUBLICATION TITLE	
IN THIS SPACE, TELL WHAT IS WRONG AND WHAT SHOULD BE DONE ABOUT IT.				
PAGE NO.	PARA-GRAPH	FIGURE NO.	TABLE NO.	
PRINTED NAME, GRADE OR TITLE AND TELEPHONE NUMBER			SIGN HERE	

**DA** FORM 1 JUL 79 **2028-2**

PREVIOUS EDITIONS ARE OBSOLETE.

P.S.--IF YOUR OUTFIT WANTS TO KNOW ABOUT YOUR RECOMMENDATION MAKE A CARBON COPY OF THIS AND GIVE IT TO YOUR HEADQUARTERS.

# THE METRIC SYSTEM AND EQUIVALENTS

## WEIGHT MEASURE

1 Centimeter = 10 Millimeters = 0.01 Meters = 0.3937 Inches  
 1 Meter = 100 Centimeters = 1000 Millimeters = 39.37 Inches  
 1 Kilometer = 1000 Meters = 0.621 Miles

## WEIGHTS

1 Gram = 0.001 Kilograms = 1000 Milligrams = 0.035 Ounces  
 1 Kilogram = 1000 Grams = 2.2 lb.  
 1 Metric Ton = 1000 Kilograms = 1 Megagram = 1.1 Short Tons

## LIQUID MEASURE

1 Milliliter = 0.001 Liters = 0.0338 Fluid Ounces  
 1 Liter = 1000 Milliliters = 33.82 Fluid Ounces

## SQUARE MEASURE

1 Sq. Centimeter = 100 Sq. Millimeters = 0.155 Sq. Inches  
 1 Sq. Meter = 10,000 Sq. Centimeters = 10.76 Sq. Feet  
 1 Sq. Kilometer = 1,000,000 Sq. Meters = 0.386 Sq. Miles

## CUBIC MEASURE

1 Cu. Centimeter = 1000 Cu. Millimeters = 0.06 Cu. Inches  
 1 Cu. Meter = 1,000,000 Cu. Centimeters = 35.31 Cu. Feet

## TEMPERATURE

$5/9(^{\circ}\text{F} - 32) = ^{\circ}\text{C}$   
 212° Fahrenheit is equivalent to 100° Celsius  
 90° Fahrenheit is equivalent to 32.2° Celsius  
 32° Fahrenheit is equivalent to 0° Celsius  
 $9/5^{\circ}\text{C} + 32 = ^{\circ}\text{F}$

## APPROXIMATE CONVERSION FACTORS

TO CHANGE	TO	MULTIPLY BY
Inches	Centimeters	2.540
Feet	Meters	0.305
Yards	Meters	0.914
Miles	Kilometers	1.609
Square Inches	Square Centimeters	6.451
Square Feet	Square Meters	0.093
Square Yards	Square Meters	0.836
Square Miles	Square Kilometers	2.590
Acres	Square Hectometers	0.405
Cubic Feet	Cubic Meters	0.028
Cubic Yards	Cubic Meters	0.765
Fluid Ounces	Milliliters	29.573
its	Liters	0.473
arts	Liters	0.946
allons	Liters	3.785
Ounces	Grams	28.349
Pounds	Kilograms	0.454
Short Tons	Metric Tons	0.907
Pound-Feet	Newton-Meters	1.356
Pounds per Square Inch	Kilopascals	6.895
Miles per Gallon	Kilometers per Liter	0.425
Miles per Hour	Kilometers per Hour	1.609

TO CHANGE	TO	MULTIPLY BY
Centimeters	Inches	0.394
Meters	Feet	3.280
Meters	Yards	1.094
Kilometers	Miles	0.621
Square Centimeters	Square Inches	0.155
Square Meters	Square Feet	10.764
Square Meters	Square Yards	1.196
Square Kilometers	Square Miles	0.386
Square Hectometers	Acres	2.471
Cubic Meters	Cubic Feet	35.315
Cubic Meters	Cubic Yards	1.308
Milliliters	Fluid Ounces	0.034
Liters	Pints	2.113
Liters	Quarts	1.057
ers	Gallons	0.264
ms	Ounces	0.035
ograms	Pounds	2.205
Metric Tons	Short Tons	1.102
Newton-Meters	Pounds-Feet	0.738
Kilopascals	Pounds per Square Inch	0.145
ometers per Liter	Miles per Gallon	2.354
ometers per Hour	Miles per Hour	0.621



